



Operator's Manual

SLXi-DRC Single Temperature Units

Revision B

Introduction

This manual is published for informational purposes only and the information furnished herein should not be considered as all-inclusive or meant to cover all contingencies. If more information is required, consult your Thermo King Service Directory for the location and telephone number of the local dealer.

Thermo King's warranty shall not apply to any equipment which has been "so installed, maintained, repaired or altered as, in the manufacturer's judgment, to affect its integrity."

Manufacturer shall have no liability to any person or entity for any personal injury, property damage or any other direct, indirect, special, or consequential damages whatsoever, arising out of the use of this manual or any information, recommendations or descriptions contained herein. The procedures described herein should only be undertaken by suitably qualified personnel. Failure to implement these procedures correctly may cause damage to the Thermo King unit or other property or personal injury.

There is nothing complicated about operating and maintaining your Thermo King unit, but a few minutes studying this manual will be time well spent.

Performing pre-trip checks and enroute inspections on a regular basis will minimize operating problems. A regular maintenance program will also help to keep your unit in top operating condition. If factory recommended procedures are followed, you will find that you have purchased the most efficient and dependable temperature control system available.

All service requirements, major and minor, should be handled by a Thermo King dealer for four very important reasons:

- They are equipped with the factory recommended tools to perform all service functions.
- They have factory trained and certified technicians.
- They have genuine Thermo King replacement parts.
- The warranty on your new unit is valid only when the repair and replacement of component parts is performed by an authorized Thermo King dealer.

Software License

The product includes software that is licensed under a non-exclusive, non-sublicensable, terminable and limited license to use the software as installed on the product for its intended purpose. Any removal, reproduction, reverse engineering, or other unauthorized use of the software is strictly prohibited. Hacking the product or installing unapproved software may void the warranty. The owner or operator shall not reverse engineer, decompile, or disassemble the software, except and only to the extent that such activity is expressly permitted by applicable law notwithstanding this limitation. The product may include third party software separately licensed as specified in any documentation accompanying the product or in an about screen on a mobile application or website that interfaces with the product.

Customer Satisfaction Survey

Let your voice be heard!

Your feedback will help improve our manuals. The survey is accessible through any internet-connected device with a web browser.

Scan the Quick Response (QR) code or click [Technical Publications TK Americas Feedback](#) to complete the survey.



Table of Contents

Safety Precautions	9
Danger, Warning, Caution, and Notice	9
General Safety Practices	9
Automatic Start/Stop Operation	10
Battery Installation and Cable Routing	10
Refrigerant	11
Refrigerant Oil	12
First Aid	13
Safety Decals and Locations	15
Operation	15
Remote Start of the Unit	16
Refrigerant	16
Do Not Use Ether Starting Aids	17
General Information	18
Diesel Engine	18
Extended Life Coolant (ELC)	18
EMI 3000	19
Thermo King Reciprocating Compressor	19
Electronic Throttling Valve	20
SMART REEFER 3 (SR-3) Control System	20
Continuous Run Operation	21
CYCLE-SENTRY™ Start-Stop Controls	21
TracKing® ConnectedSuite™	21
Further Communication Capabilities	22
OptiSet™ Plus	22
FreshSet™	23

Defrost	23
Engine Compartment	23
Unit Protection Devices	24
Manual Pretrip Inspection (Before Starting the Unit)	26
Operating Instructions	28
SMART REEFER 3 (SR-3) Controller Overview	28
Switching "ON" the Unit	28
Microprocessor ON/OFF switch	29
HMI Control Panel	29
Control Panel Display	29
Control Panel Keys	30
Turning Unit On	31
If a Language is Enabled	32
Turning The Unit Off	34
Standard Display	35
Standard Display Variations	35
Temperature Watch Display	36
Alarm Display	37
Starting the Diesel Engine	38
Unit Fails To Start	38
After Start Inspection	38
Changing The Setpoint	39
Numerical Setpoints	39
Named Products - OptiSet Plus	40
Both Numerical Setpoints and Named Products	40
Changing the Setpoint - Numerical Setpoint	41

Changing the Setpoint - Named Product	44
Changing the Setpoint - Both Numerical Setpoint and Named Product Available	47
Selection of Operating Modes	48
Selecting Cycle Sentry or Continuous Mode	49
Initiating a Manual Defrost Cycle	51
Terminating a Defrost Cycle	52
Using the Gauges Key	52
Gauges Available	53
Using the Sensors Key	54
Sensors Available	55
Using the Main Menu	56
Main Menu Choices	57
Language Menu	57
Alarms Menu	61
Important Alarm Notes	63
Datalogger Menu	64
Initiating a Start of Trip	64
Printing a Trip Report	65
Hourmeters Menu	66
Mode Menu	68
Turn Cycle Sentry On or Off	69
Select Temperature Units	70
Keypad Lockout	71
Start Sleep Mode	71
Pretrip	72
Pretrip Test Conditions	72
Conditions Where Pretrip Tests are Not Allowed	72

Pretrip Test Considerations	73
Pretrip Test Sequence	73
Performing a Pretrip Test	73
Adjust Brightness	77
Time	78
Alarm Codes	80
Introduction	80
Alarm Types	80
Log Alarm	80
Check Alarm	81
Prevent Alarm	81
Shutdown Alarm	82
Pretrip Alarms	83
Low Battery Voltage	83
Alarm Codes When Switching Between Diesel and Electric	83
Clearing Alarm Codes	83
Loading and Inspection Procedures	93
Pre-Loading Inspection	93
Post-Loading Inspection	94
Enroute Inspections	95
Inspection Procedure	95
Inspection Troubleshooting	95
Jump Starting	98
Specifications	102
Engine	102

Refrigeration System 103

Electrical Control System..... 103

TrackKing® ConnectedSuite™ 103

Maintenance Inspection Schedule105

Serial Number Locations108

Emergency Cold Line109

Warranty.....110

 EPA and ARB Supplemental Emissions Warranty
 Statement..... 110

CALIFORNIA Proposition 65 Warning111

Safety Precautions

Danger, Warning, Caution, and Notice

Thermo King® recommends that all service be performed by a Thermo King dealer and to be aware of several general safety practices.

Safety advisories appear throughout this manual as required. Your personal safety and the proper operation of this unit depend upon the strict observance of these precautions. The four types of advisories are defined as follows:

▲ DANGER

Hazard!

Indicates an imminently hazardous situation which, if not avoided, will result in death or serious injury.

▲ WARNING

Hazard!

Indicates a potentially hazardous situation which, if not avoided, could result in death or serious injury.

▲ CAUTION

Hazard!

Indicates a potentially hazardous situation which, if not avoided, could result in minor or moderate injury and unsafe practices.

NOTICE

Hazard!

Indicates a situation that could result in equipment or property-damage only accidents.

General Safety Practices

▲ DANGER

Risk of Injury!

Keep hands and loose clothing clear of fans and belts at all times when the unit is operating with the doors open.

Safety Precautions**⚠ WARNING****Risk of Injury!**

Do not apply heat to a closed cooling system. Before applying heat to a cooling system, drain it. Then flush it with water and drain the water. Antifreeze contains water and ethylene glycol. The ethylene glycol is flammable and can ignite if the antifreeze is heated enough to boil off the water.

⚠ CAUTION**Sharp Edges!**

Exposed coil fins can cause lacerations. Service work on the evaporator or condenser coils should only be accomplished by a certified Thermo King technician.

Automatic Start/Stop Operation**⚠ CAUTION****Risk of Injury!**

The unit can start and run automatically any time the unit is turned on. Turn the unit On/Off switch Off before doing inspections or working on any part of the unit. Please note that only Qualified and Certified personnel should attempt to service your Thermo King unit.

Battery Installation and Cable Routing**⚠ WARNING****Hazard of Explosion!**

An improperly installed battery could result in a fire, explosion, or injury. A Thermo King approved battery must be installed and properly secured to the battery tray.

⚠ WARNING**Hazard of Explosion!**

Improperly installed battery cables could result in a fire, explosion, or injury. Battery cables must be installed, routed, and secured properly to prevent them from rubbing, chaffing, or making contact with hot, sharp, or rotating components.

⚠ WARNING

Fire Hazard!

Do not attach fuel lines to battery cables or electrical harnesses. This has the potential to cause a fire and could cause serious injury or death.

⚠ WARNING

Personal Protective Equipment (PPE) Required!

A battery can be dangerous. A battery contains a flammable gas that can ignite or explode. A battery stores enough electricity to burn you if it discharges quickly. A battery contains battery acid that can burn you. Always wear goggles or safety glasses and personal protective equipment when working with a battery. If you get battery acid on you, immediately flush it with water and get medical attention.

⚠ WARNING

Hazard of Explosion!

Always cover battery terminals to prevent them from making contact with metal components during battery installation. Battery terminals grounding against metal could cause the battery to explode.

⚠ CAUTION

Hazardous Service Procedures!

Set all unit electrical controls to the OFF position before connecting battery cables to the battery to prevent unit from starting unexpectedly and causing personal injury.

NOTICE

Equipment Damage!

Do not connect other manufacturer's equipment or accessories to the unit or to the TK Batteries unless approved by Thermo King. Failure to do so can result in severe damage to equipment and void the warranty.

Refrigerant

Although fluorocarbon refrigerants are classified as safe, use caution when working with refrigerants or in areas where they are being used.

Safety Precautions

⚠ DANGER

Hazardous Gases - Personal Protective Equipment (PPE) Required!

Refrigerant in the presence of an open flame, spark, or electrical short produces toxic gases that are severe respiratory irritants which can cause serious injury or possible death. When working with or around hazardous chemicals, ALWAYS refer to appropriate Material Data Safety Sheets (MSDS) and OSHA/GHS (Global Harmonized System of Classification and Labelling of Chemicals) guidelines for information on allowable personal exposure levels, proper respiratory protection, and handling instructions.

⚠ DANGER

Refrigerant Vapor Hazard!

Do not inhale refrigerant. Use caution when working with refrigerant or a refrigeration system in any confined area with a limited air supply. Refrigerant displaces air and can cause oxygen depletion, resulting in suffocation and possible death. When working with or around hazardous chemicals, ALWAYS refer to appropriate Material Data Safety Sheets (MSDS) and OSHA/GHS (Global Harmonized System of Classification and Labelling of Chemicals) guidelines for information on allowable personal exposure levels, proper respiratory protection, and handling instructions.

⚠ WARNING

Personal Protective Equipment (PPE) Required!

Refrigerant in a liquid state evaporates rapidly when exposed to the atmosphere, freezing anything it contacts. Wear butyl lined gloves and other clothing and eye wear when handling refrigerant to help prevent frostbite. When working with or around hazardous chemicals, ALWAYS refer to appropriate Material Data Safety Sheets (MSDS) and OSHA/GHS (Global Harmonized System of Classification and Labelling of Chemicals) guidelines for information on allowable personal exposure levels, proper respiratory protection, and handling instructions.

Refrigerant Oil

Observe the following precautions when working with or around refrigerant oil:

⚠ WARNING

Personal Protective Equipment (PPE) Required!

Protect your eyes from contact with refrigerant oil. The oil can cause serious eye injuries. Protect skin and clothing from prolonged or repeated contact with refrigerant oil. To prevent irritation, wash your hands and clothing thoroughly after handling the oil. Rubber gloves are recommended. When working with or around hazardous chemicals, ALWAYS refer to appropriate Material Data Safety Sheets (MSDS) and OSHA/GHS (Global Harmonized System of Classification and Labelling of Chemicals) guidelines for information on allowable personal exposure levels, proper respiratory protection, and handling instructions.

First Aid

REFRIGERANT

- **Eyes:** For contact with liquid, immediately flush eyes with large amounts of water and get prompt medical attention.
- **Skin:** Flush area with large amounts of warm water. Do not apply heat. Remove contaminated clothing and shoes. Wrap burns with dry, sterile, bulky dressing to protect from infection. Get prompt medical attention. Wash contaminated clothing before reuse.
- **Inhalation:** Move victim to fresh air and use Cardio Pulmonary Resuscitation (CPR) or mouth-to-mouth resuscitation to restore breathing, if necessary. Stay with victim until emergency personnel arrive.
- **Frost Bite:** In the event of frost bite, the objectives of First Aid are to protect the frozen area from further injury, warm the affected area rapidly, and to maintain respiration.

REFRIGERANT OIL

- **Eyes:** Immediately flush with large amounts of water for at least 15 minutes. Get prompt medical attention.
- **Skin:** Remove contaminated clothing. Wash thoroughly with soap and water. Get medical attention if irritation persists.
- **Inhalation:** Move victim to fresh air and use Cardio Pulmonary Resuscitation (CPR) or mouth-to-mouth resuscitation to restore breathing, if necessary. Stay with victim until emergency personnel arrive.

Safety Precautions

- **Ingestion:** Do not induce vomiting. Immediately contact local poison control center or physician.

ENGINE COOLANT

- **Eyes:** Immediately flush with large amounts of water for at least 15 minutes. Get prompt medical attention.
- **Skin:** Remove contaminated clothing. Wash thoroughly with soap and water. Get medical attention if irritation persists.
- **Ingestion:** Do not induce vomiting. Immediately contact local poison control center or physician.

BATTERY ACID

- **Eyes:** Immediately flush with large amounts of water for at least 15 minutes. Get prompt medical attention. Wash skin with soap and water.
- **Skin:** Immediately remove contaminated clothing. Wash skin with large volumes of water, for at least 15 minutes. Wash skin with soap and water. Do not apply fatty compounds. Seek immediate medical assistance.
- **Inhalation:** Provide fresh air. Rinse mouth and nose with water. Seek immediate medical assistance.
- **Ingestion:** If the injured person is fully conscious: make the person drink extensive amounts of milk. Do not induce vomiting. Take the injured person immediately to a hospital.

ELECTRICAL SHOCK

Take IMMEDIATE action after a person has received an electrical shock. Get quick medical assistance, if possible.

The source of the shock must be quickly stopped, by either shutting off the power or removing the victim. If the power cannot be shut off, the wire should be cut with a non-conductive tool, such as a wood-handle axe or thickly insulated cable cutters. Rescuers should wear insulated gloves and safety glasses, and avoid looking at wires being cut. The ensuing flash can cause burns and blindness.

If the victim must be removed from a live circuit, pull the victim away with a non-conductive material. Use wood, rope, a belt or coat to pull or push the victim away from the current. **DO NOT TOUCH** the victim. You will receive a shock from current flowing through the victim's body. After separating the victim from power source, immediately check for signs of a pulse and respiration. If no pulse is present, start Cardio Pulmonary Resuscitation (CPR). If a pulse is present, respiration might be restored by using mouth-to-mouth resuscitation. Call for emergency medical assistance.

ASPHYXIATION

Move victim to fresh air and use Cardio Pulmonary Resuscitation (CPR) or mouth-to-mouth resuscitation to restore breathing, if necessary. Stay with victim until emergency personnel arrive.

Safety Decals and Locations

Operation

The Operation decal is located on your HMI or rear remote controller (if fitted). This decal gives you the information to access/download your unit operator manual and other supporting documentation and in many supported languages.

Figure 1. Operation Decal



BEN525

Remote Start of the Unit

⚠ CAUTION

Risk of Injury!

The unit can start and run automatically any time the unit is turned on. Turn the unit On/Off switch Off before doing inspections or working on any part of the unit. Please note that only Qualified and Certified personnel should attempt to service your Thermo King unit.

Decals located behind service door.

Note: Only present on units fitted with TK TrackKing Telematic's installed.



TrackKing Decal

Refrigerant

Refrigerant decal located on frame inside door.



BEN501

F Gas decal indicates that this equipment Contains fluorinated greenhouse gases.



SAP1243

Do Not Use Ether Starting Aids

Figure 2. Do Not Use Ether Starting Aids (Near Engine)



AMA1584

General Information

The Thermo King SLXi models are one piece, self-contained, diesel powered cooling/ heating units operating under the control of a Smart Reefer 3 (SR-3) programmable microprocessor controller. The unit mounts on the front of the trailer with the evaporator extending through an opening in the front wall.

- SLXi-DRC: Cooling and heating on diesel engine operation.



Diesel Engine

SLXi-DRC units use a 4-cylinder, water cooled, direct injection diesel engine. The engine is coupled directly to the compressor on standard units. Belts transmit power to the fans (behind the condenser coil/radiator), water pump, and alternator on all models.

Extended Life Coolant (ELC)

ELC (Extended Life Coolant) is standard equipment. The maintenance interval for ELC is five years or 12,000 hours. A nameplate on the coolant expansion tank identifies units with ELC. The new engine coolant, Chevron

Extended Life Coolant, is RED in color instead of the previous GREEN or BLUE-GREEN colored conventional coolants.

NOTICE

System Contamination!

Do not add "GREEN" or "BLUE-GREEN" conventional coolant to cooling systems using "RED" Extended Life Coolant, except in an emergency. If conventional coolant is added to Extended Life Coolant, the coolant must be changed after 2 years instead of 5 years.

Note: *The use of 50/50 percent pre-mixed Extended Life Coolant (ELC) is recommended to assure that de-ionized water is being used. If 100 percent full strength concentrate is used, de-ionized or distilled water is recommended over tap water to insure the integrity of the cooling system is maintained.*

EMI 3000

EMI 3000 is an extended maintenance interval package. It is standard equipment. The EMI 3000 package consists of the following key components:

- EMI 3000-Hour Cyclonic Air Cleaner Assembly and Air Cleaner Element
- EMI 5-Micron 3000-Hour Fuel Filter
- EMI 3000-Hour Dual Element Oil Filter
- API Rating CI-4 Mineral Oil
- Five Year or 12,000 Hour ELC (Extended Life Coolant)

The EMI package allows standard maintenance intervals for air cleaner, air cleaner element, fuel filter and dual element oil filter to be extended to 3,000 hours, or 2 years, whichever occurs first.

Note: *Units equipped with the EMI 3000 package do require regular inspection in accordance with Thermo King's maintenance recommendations.*

Thermo King Reciprocating Compressor

The SLXi-DRC units are equipped with a 4-cylinder 30.0 cu. in. (492 cm³) displacement Thermo King X430 reciprocating compressor.

General Information

Electronic Throttling Valve

The Electronic Throttling Valve (ETV) provides enhanced control of the refrigeration system as follows:

- Allows the refrigeration system to fully utilize the power capabilities of the engine under varying conditions.
- Provides an additional measure of protection against high discharge pressures.
- Protects the engine from high coolant temperature shutdowns.
- Provides a means of precise temperature control.

SMART REEFER 3 (SR-3) Control System

▲ CAUTION

Risk of Injury!

Do not operate the SR-3 Controller until you are completely familiar with its function.

The SR-3 is a microprocessor control system designed for a transport refrigeration system. The SR-3 integrates the following functions:

- Changing setpoint and operating mode
- Viewing gauge, sensor, and hourmeter readings
- Initiating Defrost cycles
- Viewing and clearing alarms

The microprocessor components are located inside the control box, which is located inside the lower roadside service door. The microprocessor is connected to a Human Machine Interface (HMI) Control Panel. It is used to operate the unit. The HMI control panel is mounted on the face of the control box. It is clearly visible through an opening in the lower roadside service door.

Refer to “Operating Instructions” for more information about the SR-3 Controller.

Depending on the air temperature in the trailer, as sensed by the microprocessor Base Controller, the unit will typically operate in one of the following modes.

Continuous Run Operation

In diesel operation the microprocessor will select the operating mode from the following:

- High Speed Cool
- Low Speed Cool
- Low Speed Modulated Cool
- Low Speed Modulated Heat
- Low Speed Heat
- High Speed Heat
- Defrost

CYCLE-SENTRY™ Start-Stop Controls

WARNING

Risk of Injury!

The unit can start at any time without warning. Press the OFF key on the HMI control panel, place the unit Service Switch (On/Off switch) in the Off position, and disconnect the battery before inspecting or servicing any part of the unit.

The CYCLE-SENTRY Start-Stop fuel saving system provides optimum operating economy. When CYCLE-SENTRY Mode is selected the unit will start and stop automatically to maintain setpoint, keep the engine warm and the battery charged. When Continuous Mode is selected, the unit starts automatically and runs continuously to maintain setpoint and provide constant airflow.

TracKing® ConnectedSuite™

SLXi-DRC units are equipped with TracKing ConnectedSuite communication device that when enabled allows remote access to unit data. Downloading the Thermo King Reefer mobile app, will allow you to monitor and manage temperature and reefer settings over the road, in the yard or in-cab via Bluetooth®.

Contact your Thermo King representative for more information about all the features and options available with TracKing ConnectedSuite.

Note: Refer to ("*TracKing® ConnectedSuite™*," p. 103) for Specifications.

Further Communication Capabilities

Cable connection: when using a laptop with WinTrac™ software.

ServiceWatch™: ServiceWatch is standard equipment. It records operating events, alarm codes, and compartment temperatures as they occur and at preset intervals. This information is typically used to analyze unit performance. Use a USB port to download the ServiceWatch data.

Important: *A ServiceWatch download can be helpful when diagnosing a problem. Therefore, it is recommended that a ServiceWatch download be performed to help diagnose a problem. A ServiceWatch download must be performed before contacting the Thermo King Service Department for assistance in diagnosing a problem.*

CargoWatch™: CargoWatch data logging requires the installation of optional sensors. Up to six temperature sensor/probes and four door switches can be installed. CargoWatch also logs the setpoint. Use the CargoWatch Port to download the CargoWatch data. If optional temperature sensors are installed, the readings are displayed as Datalogger Sensor (1-6) Temperature in the sensor readings. Refer to ("[Using the Sensors Key](#)," p. 54).

Printer Port: This port is used to print trip records from the CargoWatch™ datalogger download. It is located inside the control box.

USB key: via the USB port provided as standard, eliminating the need for laptops and cables.

GRS connection: via TrackKing™ tool which allows online fleet and temperature management.

Wireless communication: As end customers demand increasing temperature traceability, transporters need a simple and effective means of accessing critical data.

OptiSet™ Plus

OptiSet Plus is a group of programmable functions that control how the unit will operate with specific setpoints or named products. This assures that when a particular setpoint or named product is selected, the unit will always operate the same way. This allows an entire fleet to be configured to match the customers' needs. Contact your Thermo King dealer for information about programming OptiSet Plus.

FreshSet™

FreshSet is included in OptiSet Plus. FreshSet is a demand base temperature control for fresh products. FreshSet modifies and adjusts unit airflow operation to control temperature and to maximize protection of cargo, while keeping operating costs to a minimum. Contact your Thermo King dealer for information about programming FreshSet.

Defrost

Frost gradually builds-up on evaporator coils as a result of normal operation. The unit uses hot refrigerant to defrost the evaporator coil. Hot refrigerant gas passes through the evaporator coil and melts the frost. The water flows through collection drain tubes onto the ground. The methods of defrost initiation are Automatic and Manual.

Automatic Defrost: The H.M.I. automatically initiates timed or demand defrost cycles. The H.M.I. can be programmed to initiate timed defrost cycles at intervals of 2, 4, 6, 8, or 12 hours. Demand defrost cycles occur if the differences between the return air temperature, discharge air temperature, and coil temperature exceed certain limits. The unit can enter defrost cycles as often as every 30 minutes if required.

Engine Compartment

WARNING

Risk of Injury!

The unit can start at any time without warning. Press the OFF key on the HMI control panel, place the unit Service Switch (On/Off switch) in the Off position, and disconnect the battery before inspecting or servicing any part of the unit.

CAUTION

Service Procedures!

Turn the unit off before attempting to check the engine oil.

The following maintenance items can be checked visually.

Engine Oil Dipstick: Use the engine oil dipstick to check the engine oil level.

Figure 3. Engine Oil Dipstick

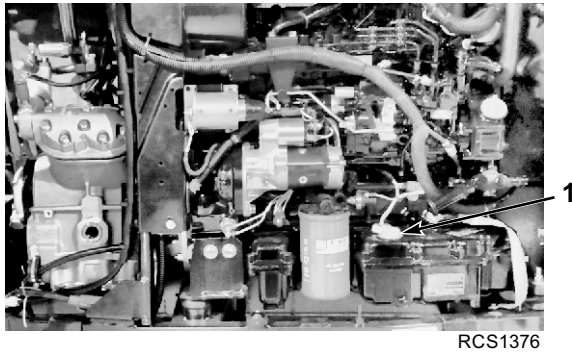

RCS1376

- | | |
|----|------------------------------|
| 1. | Engine oil dipstick location |
|----|------------------------------|

Unit Protection Devices

Coolant Temperature Switch: The coolant temperature switch closes if the coolant level drops below an acceptable level. If it stays closed for a specified time, the microprocessor records Alarm Code 37.

Engine Coolant Temperature Sensor: The microprocessor uses the engine coolant temperature sensor to monitor the engine coolant temperature. If the engine coolant temperature rises above an acceptable level, the microprocessor records Alarm Code 41 and possibly 18. The microprocessor might also shut the unit down.

High Pressure Cutout Switch: The high pressure cutout switch is located on the compressor discharge manifold. If the compressor discharge pressure becomes excessive, the switch opens the circuit to the run relay to stop the unit. The microprocessor will record Alarm Code 10.

High Pressure Relief Valve: This valve is designed to relieve excessive pressure in the refrigeration system. It is located on the receiver tank. If the high pressure relief valve opens, much of the refrigerant will be lost. Take the unit to a Thermo King dealer if this occurs.

Low Oil Level Switch: The low oil level switch closes if the oil drops below an acceptable level. If it stays closed for a specified time, the microprocessor shuts the unit down and records Alarm Code 66.

Low Oil Pressure Switch: The low oil pressure switch closes if the oil pressure drops below an acceptable level. If it stays closed for a specified time, the microprocessor shuts the unit down and records Alarm Code 19.

Preheat Buzzer: The preheat buzzer sounds when the controller energizes the preheat relay. This warns anyone near the unit that the controller is about to start the engine.

Overload Relay - Automatic Reset (SmartPower): An overload relay protects the standby electric motor. The overload relay opens the circuit to the electric motor if the motor overloads for any reason (e.g., low line voltage or improper power supply) while the unit is on electric standby operation. The microprocessor will record Alarm Code 90.

Smart FETs: Smart FETs in the base controller protect some circuits and components from an overcurrent condition.

Fuses: A number of fuses, located on the base controller, protect various circuits and components. The base controller is located inside the control box.

Fuse	Size	Function
F2	15A	2AB Power
F3	40A	Fuel Solenoid/Starter Circuit
F4	None	No Fuse - All Bosch and Thermo King Alternators
F5	60A	Preheat Circuit (See Note)
F6	15A	High Speed Solenoid Circuit
F7	2A	8FP - CAN bus
F8	5A	CAN connector J12
F9	5A	CAN connector J14
F10	10A	8X Power (Install Fuse in Upper Position)
F12	5A	CAN connector J13
F13	2A	Status Light Circuit
F15	p/s	On/Off Relay
F20	2A	Alternator Sense Circuit
F25	7.5A	High Pressure Cutout Circuit

Note: The F5 preheat fuse is a "slow blow" type fuse. It is designed for use with the Yanmar trailer engine air pre-heater. Always replace the fuse with the TK specified fuse.

Manual Pretrip Inspection (Before Starting the Unit)

Pretrip inspections are an important part of a preventative maintenance program designed to minimize operating problems and breakdowns. Perform this pretrip inspection before every trip involving refrigerated cargo.

Note: *Pretrip inspections are not intended to take the place of regular maintenance inspections.*

Fuel: Verify the diesel fuel supply is adequate to guarantee engine operation to the next check point. Allow for maximum fuel consumption of one gallon per hour of engine operation.

▲ CAUTION

Service Procedures!

Turn the unit off before attempting to check the engine oil.

Engine Oil: Check the engine oil level. It should be at the Full mark when the dipstick is threaded all the way into the oil pan. Do not overfill.

▲ CAUTION

Hazardous Pressures!

Do not remove expansion tank cap while coolant is hot.

Battery: Verify the battery terminals are tight and free of corrosion.

Belts: Verify belts are in good condition and adjusted to the proper tension. For more information about belt tension, see the Specifications chapter.

Electrical: Check the electrical connections to verify they are securely fastened. Wires and terminals should be free of corrosion, cracks, and moisture.

Structural: Visually inspect the unit for leaks, loose or broken parts, and other damage.

Coils: Verify condenser and evaporator coils are clean and free of debris.

- Washing with clean water should be sufficient.
- The use of cleaning agents or detergents is strongly discouraged due to the possibility of degradation of the construction.
- If using a power washer, the nozzle pressure should not exceed 600 psi (41 bar). For the best results, spray the coil perpendicular to the face of

Manual Pretrip Inspection (Before Starting the Unit)

the coil. The spray nozzle should be kept between 1 inch and 3 inches (25 to 75 millimeters) from the coil surface.

- If necessary to use a chemical cleaner or detergent, use a cleaner that does not contain any hydrofluoric acids and is between 7 and 8 on the pH scale. Verify dilution instructions provided by the detergent supplier are followed. In case of doubt about the compatibility of the detergent with the type of materials listed above, always ask the supplier a written confirmation of the compatibility.
- Should a chemical cleaner be required, it is **MANDATORY** that all components are thoroughly rinsed with water even if the instructions of the cleaner specify that it is a “no rinse” cleaner.

NOTICE

Equipment Damage!

Failure to comply with above mentioned guidelines will lead to a shortened life of the equipment to an indeterminable degree and also may void your warranty.

Note: *The repeated transportation of meat and fish waste can cause extensive corrosion to the evaporator coils and evaporator section tubing over time due to ammonia formation and can reduce the lifespan of the coils. Appropriate additional measures should be taken to protect the coils against the aggressive corrosion that can result from transportation of such products.*

Cargo Box: Check the interior and exterior of the cargo box for damage. Any damage to the walls or insulation must be repaired.

Cargo Doors: Verify the cargo doors and weather seals are in good condition. The doors should latch securely and the weather seals should fit tightly.

Defrost Drains: Check the defrost drain hoses to verify they are open.

Operating Instructions

SMART REEFER 3 (SR-3) Controller Overview

Thermo King has applied the latest advances in computer technology to develop a device that controls temperature and unit function, and displays operating information quickly and accurately.

There is nothing complicated about learning to operate the SR-3 Controller, but you will find that a few minutes studying the contents of this manual will be time well spent.

⚠ CAUTION

Risk of Injury!

Do not operate the SR-3 Controller until you are completely familiar with its function.

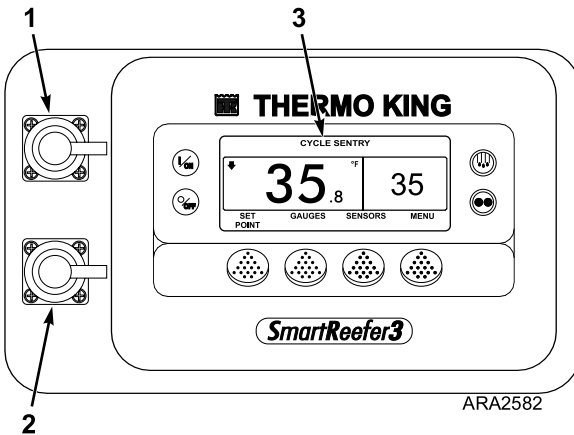

1	CargoWatch Port
2	USB Port
3	HMI Control Panel

Switching "ON" the Unit

1. On/Off Master Isolator Switch must be ON.
2. Press the I/ON Microprocessor key for one second.
3. Unit is switched "on".

Microprocessor ON/OFF switch

Microprocessor On/Off Switch is located above engine inside the unit. The switch is normally left in On position.

Figure 4. Microprocessor On/Off Switch

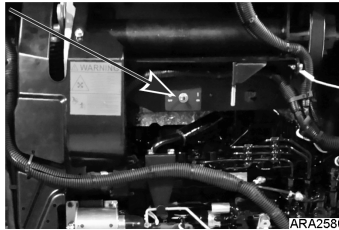

HMI Control Panel

The HMI control panel has a display and eight touch sensitive keys. The display is capable of showing both text and graphics. The four keys on the left and right sides of the display are dedicated keys. The four keys under the display are “soft” keys. The function of “soft” keys change depending on the operation being performed. If a soft key is active, its function will be shown in the display directly above the key.

Control Panel Display

The display is used to supply unit information to the operator. This information includes setpoint, current box temperature operating information, unit gauge readings, system temperatures and other information as selected by the operator.

The default display is called the Standard Display. It is shown below and will be described in detail later in this chapter.

Operating Instructions

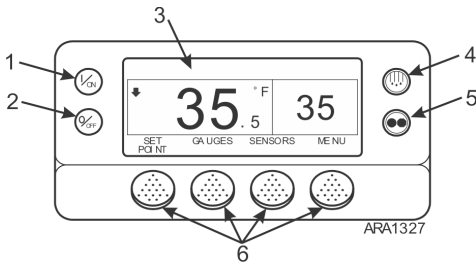

1	On Key (Dedicated Key)
2	Off Key (Dedicated Hard Key)
3	Display
4	Defrost Key (Dedicated Key)
5	CYCLE-SENTRY/ Continuous Mode Key (Dedicated Key)
6	Soft Keys

Control Panel Keys

The four keys on the left and right sides of the display screen are “dedicated keys”. Their functions are listed below.



On Key: Used to turn the unit on. First the display will briefly show the Thermo King Logo and then the statement “Configuring System - Please Wait”. When the power-up sequence is complete, the display shows the Standard Display of box temperature and setpoint.



Off Key: Used to turn the unit off. First, the display will briefly show “System is Powering Down - Please Wait. Press On to Resume” and then “Off” will appear momentarily. When the power-down sequence is complete the display will be blank.

Defrost Key: Press this key to initiate a Manual Defrost cycle.



CYCLE SENTRY/Continuous Mode Key: Press this key to switch back and forth between the CYCLE-SENTRY mode and the Continuous Run mode. If OptiSet Plus is in use, it may not be possible to change the Mode.





The four “soft” keys under the display are multi-purpose keys. Their function changes depending on the operation being performed. If a soft key is active, the key function is shown in the display directly above the key. The keys are numbered from left to right, with Key 1 on the far left and Key 4 on the far right.

Typical soft key applications:

SETPOINT	SENSORS	NEXT/BACK	+ or -	CLEAR/HELP
GAUGES	MENU	YES/NO	SELECT/EXIT	HOURLMETERS

Turning Unit On

The unit is turned on by pressing the ON Key ([Figure 5, p. 31](#)) and off by pressing the OFF Key. When the On Key is pressed, the display briefly shows the THERMO KING Logo as the display initializes.

Important: *The ON Key must be held down until the Thermo King Logo appears. If the ON Key is not held down long enough (approximately ½ second), the display may flicker but the unit will not start up. If this occurs, hold the ON Key down until the Thermo King logo appears.*

Note: *With extremely cold ambient temperatures, it may take up to 15 seconds for the display to appear on initial startup.*

Figure 5. ON Key

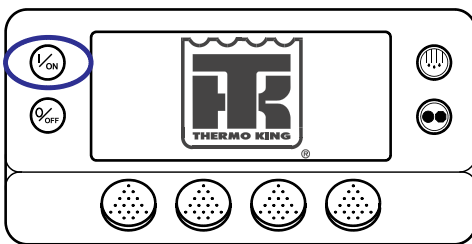

SAP201

The startup screen ([Figure 6, p. 32](#)) appears while communications are established and the unit prepares for operation.

THERMO KING

Operating Instructions

Figure 6. Startup Screen

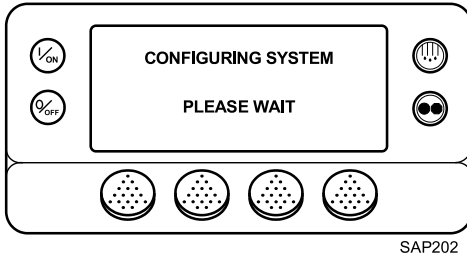

When the unit is ready to run, the Standard Display appears.

Figure 7. Standard Display

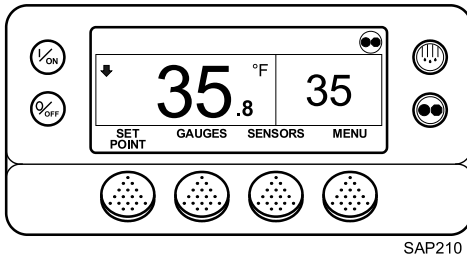

If a Language is Enabled

If more than one language has been enabled from the Guarded Access Language Menu, a prompt will appear to allow the desired language to be chosen as shown below. Only languages specifically enabled from the Guarded Access Menu are available. If a different language is desired, press the NO Key as shown (Figure 8, p. 33).

Important: *The engine start is not delayed by the language prompt shown below. The prompt will appear for 10 seconds and then the engine will start. After the engine is started, the display will return to the prompt shown below.*

Figure 8. NO Key

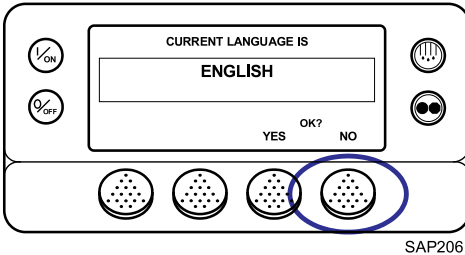

The Language menu will appear as shown (Figure 9, p. 33). Press the + or - Keys to select the desired language. When the desired language is shown, press the YES Key to confirm the choice.

Figure 9. + or -, then YES Key

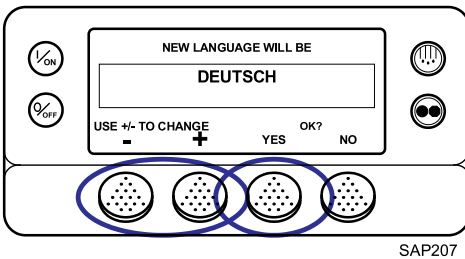

The display will briefly show PROGRAMMING LANGUAGE - PLEASE WAIT in the new language as shown (Figure 10, p. 33).

Figure 10. New Language

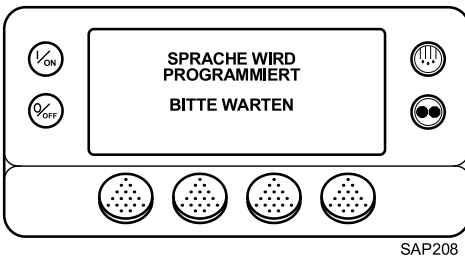

The new language is confirmed, and the Standard Display will appear in the new language as shown (Figure 11, p. 34). The unit is ready to run.

Figure 11. Standard Display with New Language

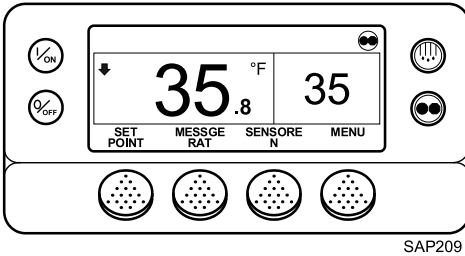

Turning The Unit Off

Pressing the OFF Key stops unit operation. The unit shuts down immediately and the display briefly shows the power down message (Figure 12, p. 34).

Figure 12. Power Down Message

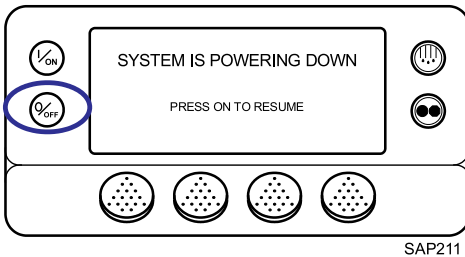

The display briefly shows OFF (Figure 13, p. 34) and then goes blank. To start the unit again, press the ON Key.

Figure 13. Display Shows OFF

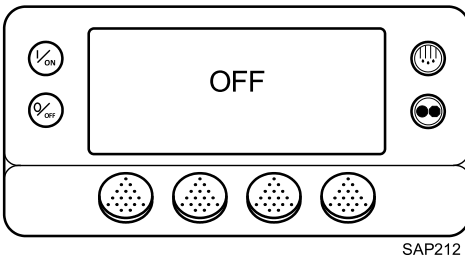

Standard Display

The Standard Display is the default display. It appears if no other display function is selected. The Standard Display shows the box temperature and setpoint. The box temperature is measured by the controlling sensor. The return air sensor is the controlling sensor except when the controller is programmed to use the discharge air sensor as the controlling sensor during modulation. The box temperature shown below is 35.5 F. The setpoint shown is 35 F. The CYCLE-SENTRY Icon in the upper right corner of the display shows the unit is operating in the CYCLE-SENTRY mode. The arrow pointing down indicates the unit is cooling.

Note: The CYCLE-SENTRY icon will appear when the unit is operating in CYCLE-SENTRY mode as shown below. If the CYCLE-SENTRY icon is not present the unit is operating in Continuous mode.

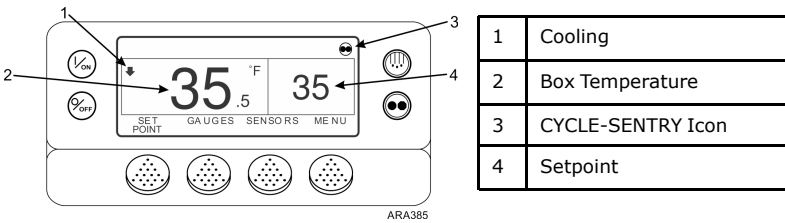

Standard Display Variations

The Standard Display has variations when OptiSet™ Plus is in use. A display showing any of the following variations is still considered a Standard Display.

Operating Instructions

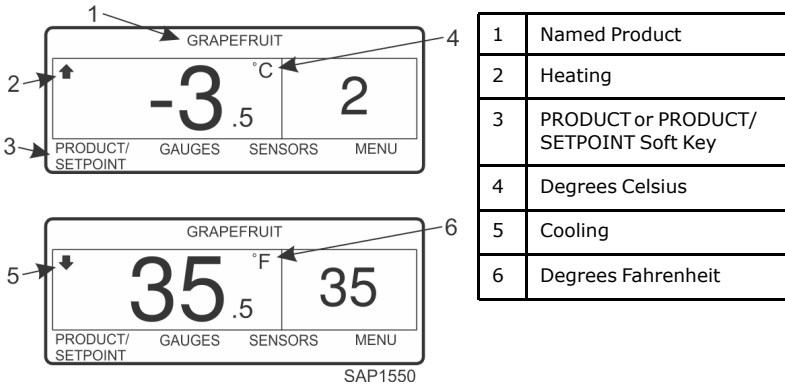

The top of the display may show a named product if the controller has been programmed with OptiSet Plus temperature profiles. The far left soft key may display PRODUCT or PRODUCT/SETPOINT if the Base Controller has been programmed with OptiSet Plus temperature profiles. Refer to ([“Changing The Setpoint,” p. 39](#)) for information about selecting or changing the named product or the setpoint if the Base Controller has been programmed with OptiSet Plus temperature profiles. Contact your Thermo King dealer for information about programming the Base Controller with OptiSet Plus temperature profiles.

The temperature can be displayed in degrees Fahrenheit (F) or degrees Celsius (C). An arrow pointing upwards indicates the unit is heating. An arrow pointing downwards indicates the unit is cooling.

Temperature Watch Display

The Standard Display defaults to the Temperature Watch Display after about 2-1/2 minutes of non-use (when no keys are pressed) and no check, prevent or shutdown alarms are present. The Temperature Watch Display shows the same box temperature and setpoint but in larger fonts. This creates easy operator viewing from a distance. To return to the Standard Display press the MENU soft key (or any of the other three soft keys that are not assigned).

Notes:

1. A named product may appear above the temperature reading if the Base Controller has been programmed with OptiSet Plus temperature profiles and a named product has been selected.
2. The CYCLE-SENTRY icon will appear in the Temperature Watch display when the unit is operating in CYCLE-SENTRY mode as shown below. If the CYCLE-SENTRY icon is not present the unit is operating in Continuous mode.

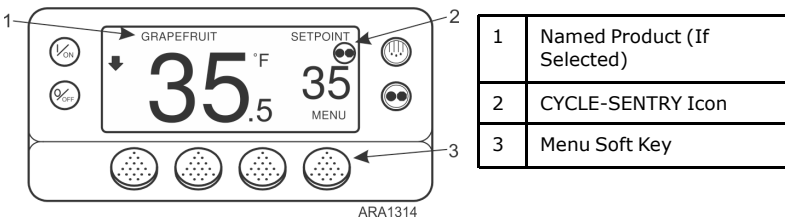

Alarm Display

If a unit alarm condition occurs the large Alarm Icon will appear on the Standard Display as shown below. Refer to (“Alarms Menu,” p. 61) for information about displaying and clearing alarms.

Important: Always record any Alarm Codes shown. This information is very valuable to service personnel.

Note: A shutdown alarm will also cause the display and backlight to flash on and off, and the display will switch from normal video to reverse video and back to normal video (light areas become dark and dark areas become light).

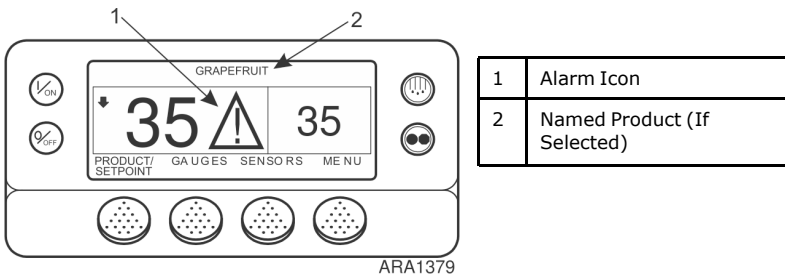

Starting the Diesel Engine

▲ CAUTION

Risk of Injury!

The engine may start automatically any time the unit is turned on.

NOTICE

Equipment Damage!

Never use starting fluid. Damage to the engine can occur.

Diesel engine preheats and starts automatically in both Continuous Mode and CYCLE-SENTRY mode. The engine will preheat and start if necessary when the unit is turned on. The engine preheat and start will be delayed in CYCLE-SENTRY mode if there is no current need for the engine to run. If a key or sequence of keys are pressed on the HMI Control Panel before the engine starts, the engine will preheat and start approximately 10 seconds after pressing the last key. Refer to ("[Turning Unit On](#)," p. 31).

Note: Run a pretrip test if the unit has not been used recently. Refer to ("[Performing a Pretrip Test](#)," p. 73).

Unit Fails To Start

If the engine does not start and the Alarm Icon appears on the display, take the following steps.

1. Check for and correct any alarm conditions. Refer to ("[Alarms Menu](#)," p. 61).
2. Clear all alarms. Refer to Clearing Alarm Codes ("[Alarm Codes](#)," p. 80).
3. Press the OFF key to turn the unit off.
4. Press the ON key to turn the unit on.
5. The Base Controller will go through the start up screens and then after a 10 second delay the unit will start automatically.
6. If the engine will still not start, turn the unit off. Determine and correct the cause for not starting.
7. Repeat the procedure.

After Start Inspection

After the unit is running, check the following items to confirm that the unit is running properly.

Oil Pressure: Check the engine oil pressure by pressing the GAUGES soft key (“Using the Gauges Key,” p. 52). The Engine Oil Pressure Display should indicate OK not LOW.

Ammeter: Check the ammeter reading by pressing the GAUGES soft key (“Using the Gauges Key,” p. 52). The Amps Display should indicate a positive charge amperage rate to the battery. A negative (-) number indicates a discharge condition.

Compressor Oil: The compressor oil level should be visible in the compressor sight glass after 15 minutes of operation. If not, check the compressor oil level using the procedure in the appropriate maintenance manual.

Pre-Cooling: Verify that the setpoint is at the desired temperature (“Changing The Setpoint,” p. 39). Allow the unit to run for a minimum of 30 minutes (longer if possible) before loading the trailer. This provides a good test of the refrigeration system while removing residual heat and the moisture from the trailer interior to prepare it for a refrigerated load.

Defrost: When the unit has finished pre-cooling the trailer interior, manually initiate a Defrost cycle (“Initiating a Manual Defrost Cycle,” p. 51). This will remove the frost that builds up while running the unit to pre-cool the trailer.

Changing The Setpoint

The Setpoint is changed from the Standard Display. If the TemperatureWatch display is present, press any key to return to the Standard Display.

Important: *If OptiSet Plus is in use, there are several possible options when changing the setpoint.*

Numerical Setpoints

If OptiSet Plus is not in use or if only Numerical Setpoints are enabled, the Standard Display left soft key will be labeled SETPOINT (Figure 14, p. 40).

THERMO KING

Operating Instructions

Figure 14. SETPOINT

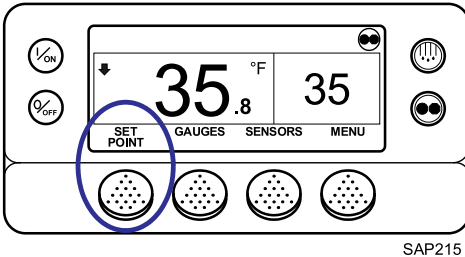

Named Products - OptiSet Plus

OptiSet Plus allows the use of Named Products such as GRAPEFRUIT or BANANAS in place of a numerical setpoint. If only named products are enabled, the Standard Display left soft key will be labeled PRODUCT (Figure 15, p. 40).

- A single setpoint temperature may be allowed for the specific named product.
- A numerical setpoint range may be allowed for the specific named product.

Figure 15. PRODUCT

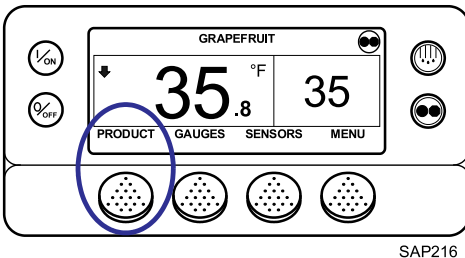

Both Numerical Setpoints and Named Products

OptiSet Plus can allow the use of both Numerical Setpoints and Named Products. If both numerical setpoints and named products are enabled, the Standard Display left soft key will be labeled PRODUCT/SETPOINT (Figure 16, p. 41).

Figure 16. PRODUCT/SETPOINT

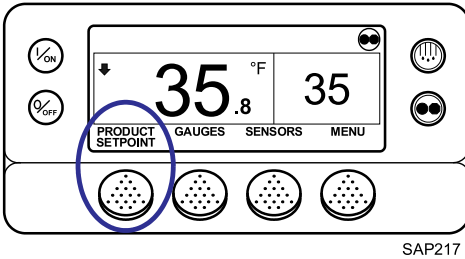

Changing the Setpoint - Numerical Setpoint

If the TemperatureWatch display is shown, press any soft key to return to the Standard Display. From the Standard Display, press the SETPOINT Key (Figure 17, p. 41).

Figure 17. SETPOINT

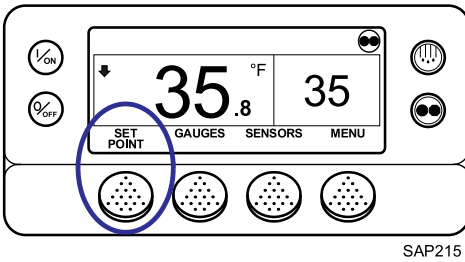

The setpoint display appears (Figure 18, p. 41).

Figure 18. Setpoint Display

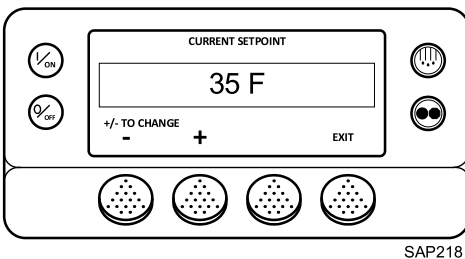

Operating Instructions

The “-” and “+” Keys are used to increase or decrease the setpoint until the desired setpoint is shown. The setpoint has been changed to 40°F using the “+” Key (Figure 19, p. 42).

Figure 19. Setpoint Changed Using “+” Key

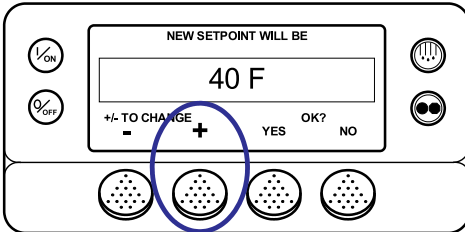

SAP219

The YES and NO Keys (Figure 20, p. 42) confirm the setpoint change. When the desired setpoint has been selected using the “+” and/or “-” Keys, press the YES Key to confirm and load the new setpoint. If the setpoint is changed using the “+” or “-” Keys, the change must be confirmed or rejected by pressing the YES or NO Key within 10 seconds of changing the setpoint. A warning beep will sound for five seconds as a reminder.

Failure to confirm the new setpoint by pressing Yes or No within 10 seconds of changing the setpoint will result in no setpoint change. In addition, Alarm Code 127 Setpoint Not Entered is set, to indicate that the setpoint change was not completed.

Figure 20. Yes and No Keys

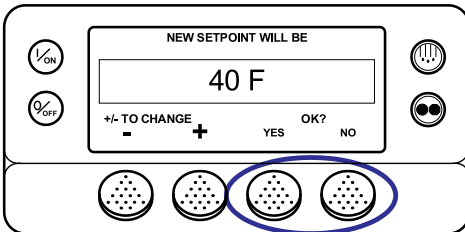

SAP220

After the YES Key has been pressed, the display briefly shows PROGRAMMING NEW SETPOINT - PLEASE WAIT. The display then confirms the new setpoint for several seconds (Figure 21, p. 43).

Figure 21. New Setpoint

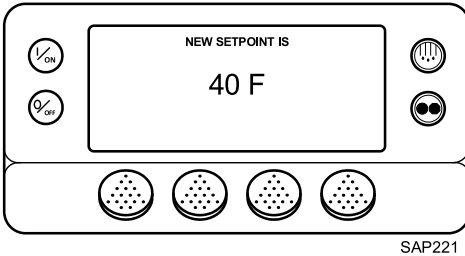

If the NO Key is pressed, the display will briefly show SETPOINT NOT CHANGED and return to the Standard Display. The Standard Display will show the old setpoint.

The display then returns to the Standard Display showing the new setpoint. Notice that the arrow now points up, to indicate that the unit is heating (Figure 22, p. 43).

Figure 22. Up Arrow

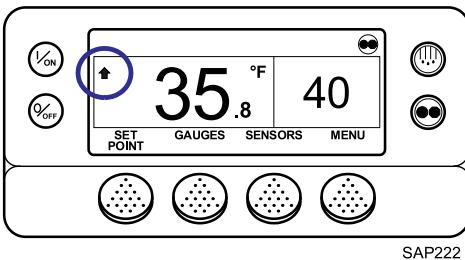

Important: If the setpoint is changed using the “+” or “-” Keys, the change must be confirmed or rejected by pressing the YES or NO Key within 10 seconds of changing the setpoint.

- If the YES Key is pressed, the setpoint change made with the “+” or “-” Key is accepted, the setpoint changes, and the display returns to the Standard Display.
- If the NO Key is pressed, the setpoint change made with the “+” or “-” Key is not accepted, the setpoint is not changed, and the display returns to the Standard Display.
- If the YES or NO Key is not pressed within 10 seconds of making a change with the “+” or “-” Key, the setpoint is not changed and the

Operating Instructions

display returns to the Standard Display. The display briefly shows [SETPOINT NOT CHANGED] and Alarm Code 127 Setpoint Not Entered is set, to indicate that the setpoint change was started but not completed.

Changing the Setpoint - Named Product

If the TemperatureWatch display is shown, press any soft key to return to the Standard Display. From the Standard Display, press the PRODUCT Key. The PRODUCT is displayed in place of SETPOINT ([Figure 23, p. 44](#)).

Figure 23. PRODUCT

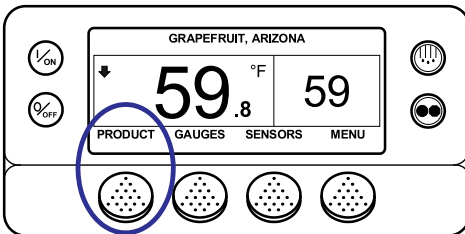

SAP223

The display briefly shows PRODUCT and then the setpoint display appears ([Figure 24, p. 44](#)).

Figure 24. Setpoint Display

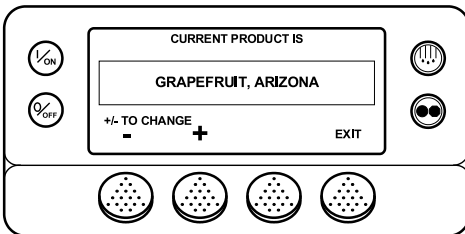

SAP224

The “-” and “+” Keys are used to change the Named Product until the desired product is shown. Here the product has been changed to Potato, Late Crop ([Figure 25, p. 45](#)).

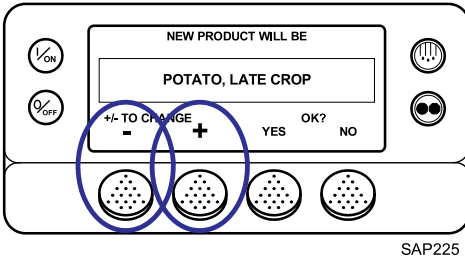
Figure 25. Named Product

The YES and NO Keys confirm the product change (Figure 26, p. 45). When the desired product has been selected using the "+" and/or "-" Keys, press the YES Key to confirm and load the new product. If the product is changed using the "+" or "-" Keys, the change must be confirmed or rejected by pressing the YES or NO Key within 10 seconds of changing the product. A warning beep will sound for five seconds as a reminder.

Failure to confirm the new product by pressing Yes or No within 10 seconds of changing the product will result in no product change. In addition, Alarm Code 127 Setpoint Not Entered is set, to indicate that the product change was not completed.

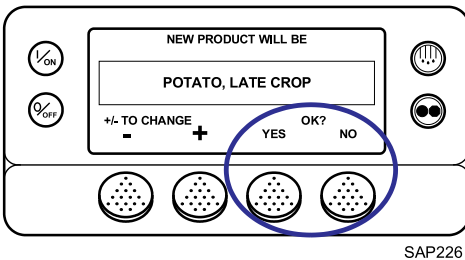
Figure 26. Yes and No Keys

After the YES Key has been pressed, the display briefly shows PROGRAMMING NAMED PRODUCT - PLEASE WAIT. The display then confirms the new setpoint for several seconds (Figure 27, p. 46).

Operating Instructions

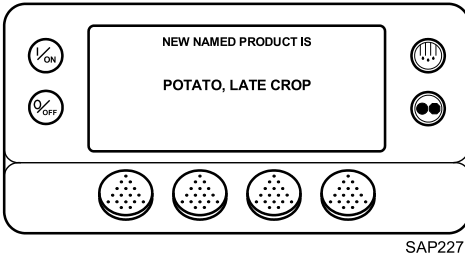
Figure 27. New Named Product

If the NO Key is pressed, the display will briefly show SETPOINT NOT CHANGED and return to the Standard Display. The Standard Display will show the old setpoint.

The display then returns to the Standard Display showing the new named product. Notice that the arrow points down, to indicate that the unit is cooling (Figure 28, p. 46).

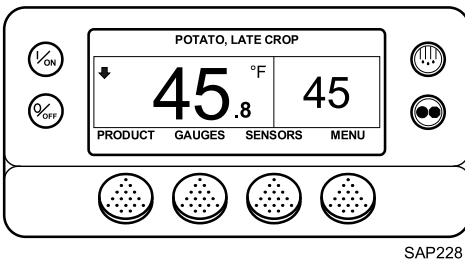
Figure 28. Standard Display

Important: If the named product is changed using the "+" or "-" Keys, the change must be confirmed or rejected by pressing the YES or NO Key within 10 seconds of changing the named product.

- If the YES Key is pressed, the product change made with the "+" or "-" Key is accepted, the product changes, and the display returns to the Standard Display.
- If the NO Key is pressed, the product change made with the "+" or "-" Key is not accepted, the product is not changed, and the display returns to the Standard Display.
- If the YES or NO Key is not pressed within 10 seconds of making a change with the "+" or "-" Key, the product is not changed and the

display returns to the Standard Display. The display briefly shows [SETPOINT NOT CHANGED] and Alarm Code 127 Setpoint Not Entered is set, to indicate that the setpoint change was started but not completed.

Changing the Setpoint - Both Numerical Setpoint and Named Product Available

If the TemperatureWatch display is shown, press any soft key to return to the Standard Display. From the Standard Display, press the SETPOINT Key. Both PRODUCT and SETPOINT are displayed as shown (Figure 29, p. 47).

Figure 29. PRODUCT/SETPOINT

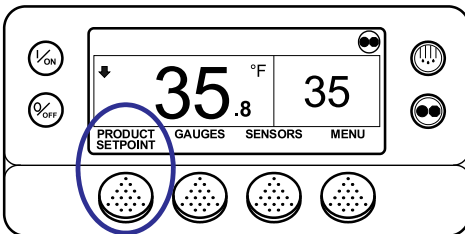

SAP217

The NAMED PRODUCT / NUMERIC SETPOINT appears briefly as shown (Figure 30, p. 47).

Figure 30. NAMED PRODUCT/NUMERIC SETPOINT Prompt

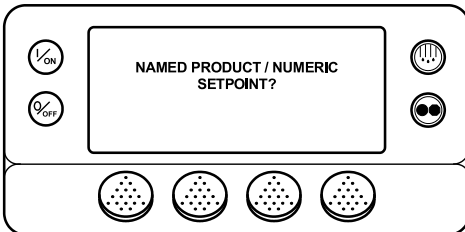

SAP229

- Press the NAMED Soft Key to proceed with Named Product change as previously shown.
- Press the NUMERIC Soft Key to proceed with Numeric Setpoint change as previously shown.
- Press the EXIT Soft Key to return to the Standard Display.

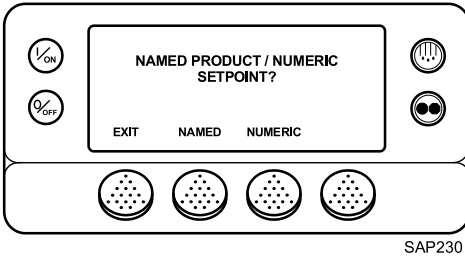
Figure 31. NAMED PRODUCT/NUMERIC SETPOINT Display

Selection of Operating Modes

The Thermo King CYCLE-SENTRY system is designed to save refrigeration fuel costs. The savings vary with the commodity, ambient temperatures and trailer insulation. However, not all temperature controlled products can be properly transported using CYCLE-SENTRY operation. Certain highly sensitive products normally require continuous air circulation. Use the following guidelines to select the proper operating mode to protect the commodity you are transporting.

Examples of products normally acceptable for CYCLE-SENTRY Operation:

- Frozen foods (in adequately insulated trailers)
- Boxed or processed meats Poultry
- Fish
- Dairy products
- Candy
- Chemicals
- Film
- All non-edible products

Examples of products normally requiring Continuous Run Operation for air flow:

- Fresh fruits and vegetables, especially asparagus, bananas, broccoli, carrots, citrus, green peas, lettuce, peaches, spinach, strawberries, sweet corn, etc.
- Non-processed meat products (unless pre-cooled to recommended temperature).
- Fresh flowers and foliage.

The above listings are not all inclusive. Consult your grower or shipper if you have any questions about the operating mode selection of your type of load.

Important: *If OptiSet Plus is in use, it may not be possible to change the Mode.*

Selecting Cycle Sentry or Continuous Mode

When Cycle Sentry Mode is selected, the unit will start and stop automatically to maintain setpoint, keep the engine warm, and the battery charged. When Continuous Mode is selected, the unit starts automatically and runs continuously to maintain setpoint and provide constant airflow.

Important: *Cycle Sentry or Continuous may not be selectable if OptiSet Plus is in use.*

If the unit is operating in Cycle Sentry Mode, the Cycle Sentry Icon will be present in the upper right corner of the display as shown (Figure 32, p. 49). If the Cycle Sentry Icon is not present, the unit is operating in Continuous Mode.

Figure 32. Cycle Sentry Icon

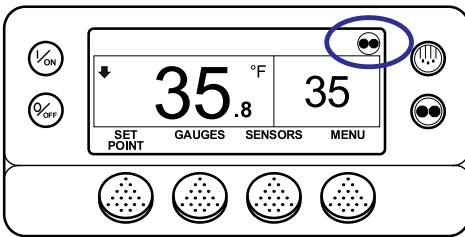

SAP240

If allowed by OptiSet Plus, Cycle Sentry Mode or Continuous Mode is selected by pressing the Cycle Sentry/Continuous Key as shown (Figure 33, p. 50).

Note: *Cycle Sentry Mode or Continuous Mode can also be selected using the Main Menu > Mode Submenu.*

THERMO KING
Operating Instructions

Figure 33. Cycle Sentry/Continuous Key

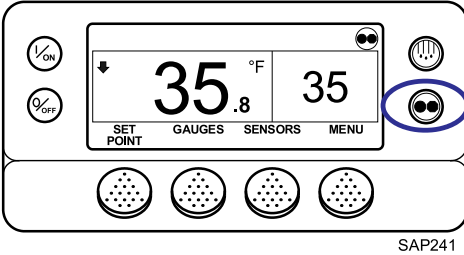

If the unit is in Cycle Sentry Mode, pressing the Cycle Sentry/Continuous Key changes the mode from Cycle Sentry to Continuous. The display confirms the change (Figure 34, p. 50).

Figure 34. Continuous Mode

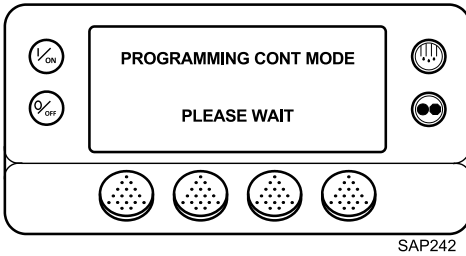

The new mode is confirmed for three seconds (Figure 35, p. 50).

Figure 35. New Mode Confirmed

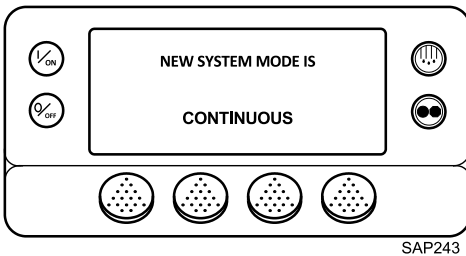

The display then returns to the Standard Display. In the example shown (Figure 36, p. 51), the absence of the Cycle Sentry Icon indicates that the unit is running in Continuous Mode.

Figure 36. Cycle Sentry Icon Not Shown = Continuous Mode

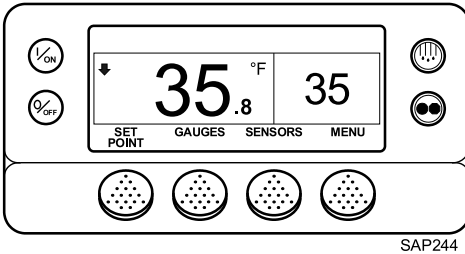

Pressing the Cycle Sentry/Continuous Key again allows the operator to change back to Cycle Sentry Mode operation.

Important: *If the unit is in Cycle Sentry null and the mode is switched to Continuous Mode, the unit will start automatically.*

Important: *Cycle Sentry or Continuous may not be selectable if OptiSet Plus is in use.*

Initiating a Manual Defrost Cycle

Defrost cycles are usually initiated automatically based on time or demand. Manual defrost is also available.

Manual defrost is available if the unit is running and the evaporator coil temperature is less than or equal to 45°F (7°C).

Note: *If Rail Alternate is set to YES, defrost is allowed with an evaporator coil temperature less than or equal to 55°F (13°C).*

Other features such as door switch settings may not allow manual defrost under some conditions. To initiate a manual defrost cycle, press the Defrost Key (Figure 37, p. 51).

Figure 37. Press Defrost Key

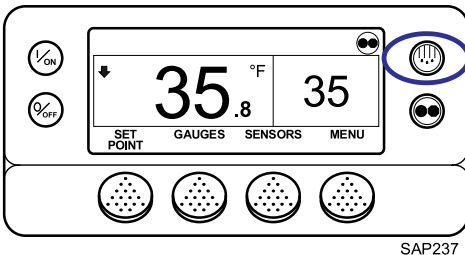

Operating Instructions

The display briefly shows [DEFROST], [PROGRAMMING DEFROST - PLEASE WAIT] and then [DEFROST STARTED] (Figure 38, p. 52).

Figure 38. Defrost Started

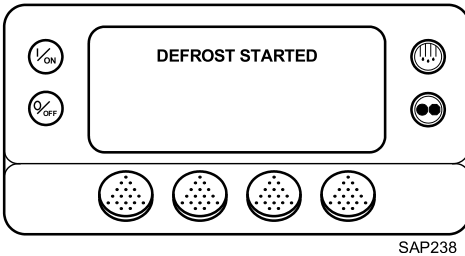

The display then shows the Defrost display. The bar indicator shows approximately how much time remains to complete the defrost cycle. The bar indicator shows that the defrost cycle is about 25% complete (Figure 39, p. 52).

Figure 39. Bar Indicator

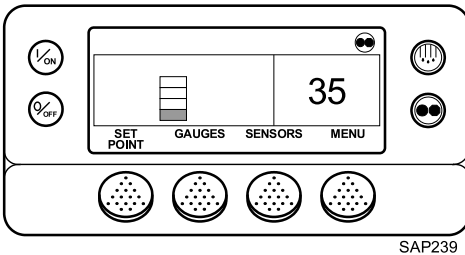

Terminating a Defrost Cycle

The defrost cycle terminates automatically when the coil temperature is greater than or equal to 58°F (14°C) or the defrost timer expires. Defrost can also be terminated by turning the unit off and back on.

Note: If Rail Alternate is set YES, the defrost cycle terminates at 70°F (21°C) or if the defrost timer expires.

Using the Gauges Key

The GAUGES Key allows the operator to view the unit gauges. To access the GAUGES Menu, press the GAUGES Key (Figure 40, p. 53).

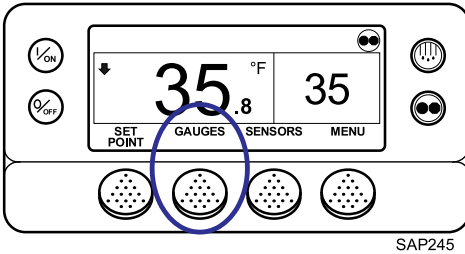
Figure 40. Gauges Key

SAP245

The first gauge display will appear. Press the NEXT and BACK Keys to scroll through the gauges. Pressing the LOCK Key will lock the current gauge on the display (Figure 41, p. 53).

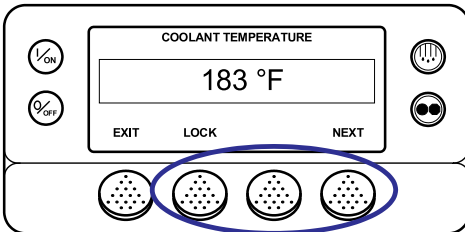
Figure 41. Gauge Display Locked

SAP246

The gauges and I/O conditions available are shown below. Not all gauges or I/O conditions may appear depending on unit configuration and software revision.

To return to the Standard Display, press the EXIT Key.

Gauges Available

Coolant Temperature: Displays the temperature of the engine coolant.

Coolant Level: Displays the coolant level in the overflow tank.

Engine Oil Pressure: Displays the engine oil pressure as OK or LOW.

Engine Oil Level Switch: Displays the engine oil level as OK or LOW.

Amps: Displays the current flow in amps flowing to or from the unit battery.

Battery Voltage: Displays the voltage of the unit battery.

Engine RPM: Displays the engine speed in RPMs.

Operating Instructions

Fuel Level Sensor: Displays the fuel level if a fuel level sensor is installed.

Discharge Pressure: Displays the unit discharge pressure. ETV units only.

Suction Pressure: Displays the unit suction pressure. ETV units only.

ETV Position: Displays the current position of the ETV valve. ETV units only.

Fresh Air Exchange: Displays the current position of the optional Fresh Air Exchange Door.

I/O (Input/Output State): Displays the current state of the input/output devices listed here:

High Speed Relay/Electric Heat	Alternator Frequency
Run Relay	Optional Fresh Air Exchange Output
Run Relay Feedback	Diesel/Electric Relay (Model 50 units only)
Alternator Excite Output	Electric Ready Input (Model 50 units only)
Defrost Damper	Electric overload (Model 50 units only)
Heat Output	Hot Gas Bypass (ETV units only)

Using the Sensors Key

The SENSORS Key allows the operator to view the temperatures read by the unit temperature sensors. To access the SENSORS Menu, press the SENSORS Key (Figure 42, p. 54).

Figure 42. Sensors Key

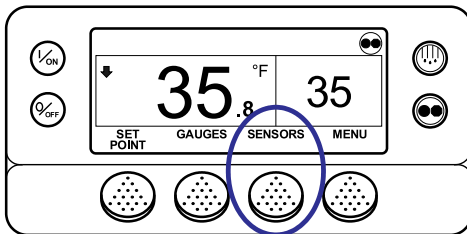

SAP247

The first sensor display will appear. Press the NEXT and BACK Keys to scroll through the sensors. Pressing the LOCK Key will lock the current sensor on the display (Figure 43, p. 55).

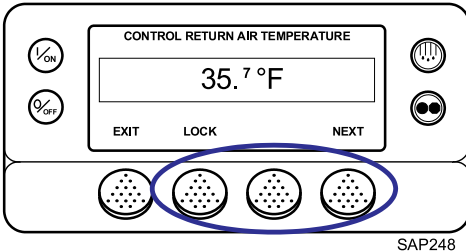
Figure 43. Sensor Display Locked

The sensors available are shown below. To return to the Standard Display, press the EXIT Key.

Sensors Available

Control Return Air Temperature: Displays the temperature of the control return air sensor.

Display Return Air Temperature: Displays the temperature of the display return air sensor.

Control Discharge Air Temperature: Displays the temperature of the control discharge air sensor.

Display Discharge Air Temperature: Displays the temperature of the display discharge air sensor.

Temperature Differential: Displays the calculated difference between the control return air sensor and the control discharge air sensor.

Evaporator Coil Temperature: Displays the temperature of the evaporator coil sensor.

Ambient Air Temperature: Displays the temperature of the ambient air sensor.

Spare 1 Temperature: Displays the temperature of the spare 1 temperature sensor.

Log Sensor 1: Displays the temperature of the CargoWatch Data Logger temperature sensor 1.

Log Sensor 2: Displays the temperature of the CargoWatch Data Logger temperature sensor 2.

Datalogger Sensor 3 Temperature: Displays the temperature of the CargoWatch Data Logger temperature sensor 3.

Operating Instructions

Datalogger Sensor 4 Temperature: Displays the temperature of the CargoWatch Data Logger temperature sensor 4.

Datalogger Sensor 5 Temperature: Displays the temperature of the CargoWatch Data Logger temperature sensor 5.

Datalogger Sensor 6 Temperature: Displays the temperature of the CargoWatch Data Logger temperature sensor 6.

Board Temperature Sensor: Displays the internal temperature of the HMI Control Panel pc board.

Using the Main Menu

The Main Menu contains several additional submenus that allow the operator to view information and modify unit operation. To access the Main Menu press the MENU Key (Figure 44, p. 56).

Figure 44. Menu Key

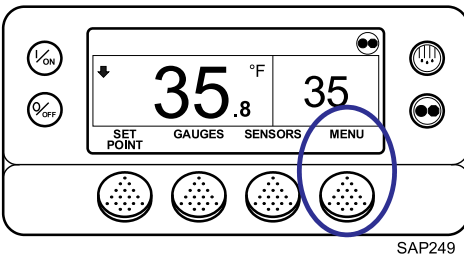

The first Main Menu choice will appear. Press the NEXT and BACK Keys to scroll through the menu choices. When the desired selection is shown on the display, press the SELECT Key to access it. The Pretrip submenu is shown (Figure 45, p. 56). To return to the Standard Display, press the EXIT Key.

Figure 45. Pretrip Submenu

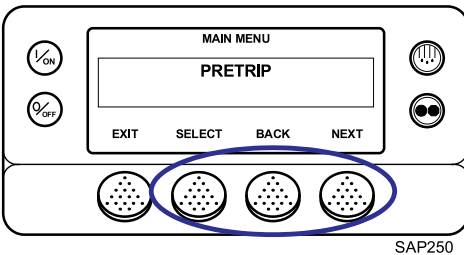

Main Menu Choices

Each of these Main Menu choices will be explained later in this section:

Flash Drive: If a properly configured USB Flash Drive is currently connected to the USB Port on the unit Control Panel, the Flash Drive Menu will appear as a Main Menu selection.

Languages: If more than one language is enabled from the Guarded Access > Language Menu, this menu item will appear.

Alarms: The Alarm Menu allows the operator to view any active alarms, and allows most alarms to be cleared.

Data Logger: Allows the operator to set a Start of Trip marker to the CargoWatch and ServiceWatch data loggers and print the contents of the CargoWatch data logger.

Hourmeters: The Hourmeters Menu allows the operator to view the unit hourmeters that have the view feature enabled in the Guarded Access Menu.

Mode: The Mode Menu allows the operator to change the unit operating modes that have been enabled in Guarded Access.

Pretrip: Allows the operator to start a Pretrip Test. If an alarm is active, the Pretrip Test is not allowed and the operator is prompted to clear the alarm (s).

Electric Standby Option: The Diesel/Electric Standby selection from the Main Menu allows the operator to manually select diesel or electric mode operation on units equipped with the electric standby option.

Diesel Mode: If a unit equipped with electric standby is running in electric mode and the Electric to Diesel Auto-Switch feature is set NO, this feature allows the operator to manually select diesel mode operation. This feature does not appear if the unit does not feature optional Electric Standby or if the Electric to Diesel Auto-Switch feature is set YES.

Adjust Brightness: The brightness of the HMI Control Panel display can be adjusted to allow for changing ambient light conditions.

Time: The Time and Date held by the HMI Control Panel can be checked. Time and Date cannot be changed from the Main Menu.

Language Menu

If the Language feature is enabled, an alternate language can be selected from the Language Menu. After a new language is chosen all displays will appear in that language. If the language feature is not enabled this menu

Operating Instructions

does not appear. The default language is English. Only languages that have been enabled in Guarded Access will appear.

Important: *Exercise care when changing languages. Once changed, all HMI Control Panel displays will be in the new language. If the user is not familiar with the new language, problems may be experienced returning to the default language.*

The languages available are dependent on the HMI Control Panel software revision. Other than the languages supported, software revisions 7Bxx, 7Cxx, 7Dxx, and 7Exx are identical.

- Software Revision 7Bxx supports English, Spanish, French, German, Italian, Dutch, Portuguese, Greek, Turkish, Hebrew and Arabic.
- Software Revision 7Cxx supports English, Danish, Russian, Norwegian, Swedish, Finnish, Polish, Hungarian, Romanian, Bulgarian and Czech.
- Software Revision 7Dxx supports English, Japanese and Chinese.
- Software Revision 7Exx supports English, English and Spanish, or allows any five languages from Software Revision 7Bxx or 7Cxx to be selected. Japanese and Chinese are not available for use with this feature.

To select an alternate language, press the MENU Key.

Figure 46. Menu Key

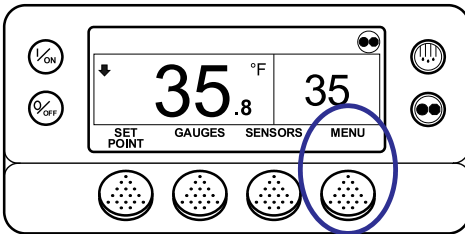

If more than one language is enabled, the Language Menu is the first Main Menu item to appear as shown. Press the SELECT Key to choose the Language Menu.

Figure 47. Main Menu - Language

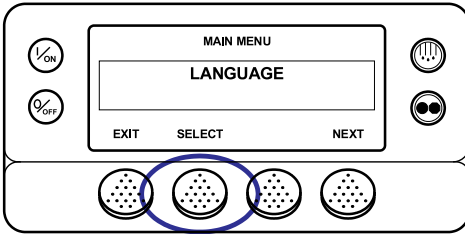

SAP282

The Language Menu will appear as shown. Press the + or – Keys to select the desired language. Only languages enabled from the Guarded Access Menu are available. When the desired language is shown, press the YES Key to confirm the choice.

Figure 48. Language Menu

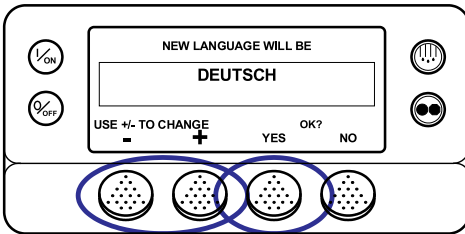

SAP207

The display will briefly show PROGRAMMING LANGUAGE - PLEASE WAIT in the new language. The display will then return to the Language Menu, but will show the new language.

Figure 49. New Language

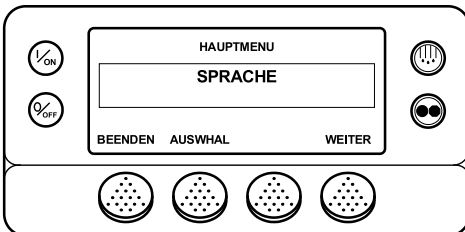

SAP283

Operating Instructions

Repeat the process to select a different language. To select a different Main Menu item press the NEXT Key. To return to the Standard Display press the EXIT Key.

Important: *If necessary, English and all other languages in the software version may be accessed from the Standard Display.*

Should it be necessary at any time to change to English or any other language in the installed software, return to the Standard Display and then press and hold the first and last soft keys for five seconds as shown. The Standard Display is shown in Deutsch (German).

Figure 50. New Language

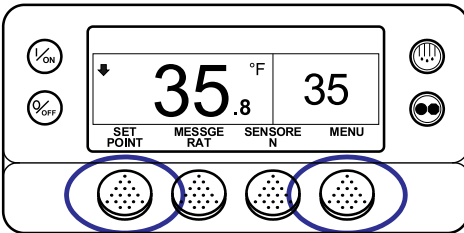

SAP284

After five seconds the Language Menu will appear in the current language as shown. Press the + or – Keys to select the desired language. When the desired language is shown, press the YES Key to confirm the choice.

Note: *All languages in the installed software can be selected using this method.*

Figure 51. Language Menu

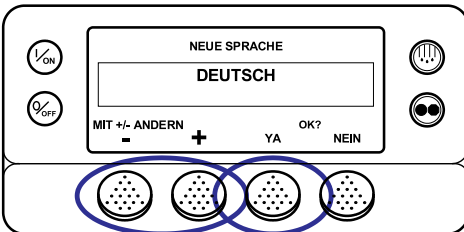

SAP285

Alarms Menu

If an alarm condition occurs, the large Alarm Icon will appear on the Standard Display (“Alarm Display,” p. 37).

Alarms are displayed and cleared using the Alarm Menu. From the Standard Display, press the MENU Key.

Figure 52. Menu Key

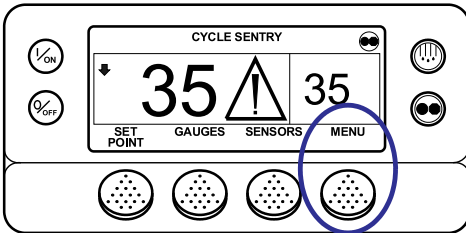

SAP288

The Language Menu or Alarms Menu will appear. If the Language Menu appears press the NEXT Key to show the Alarms Menu. When the Alarms Menu is shown, press the SELECT Key.

Figure 53. Select Key

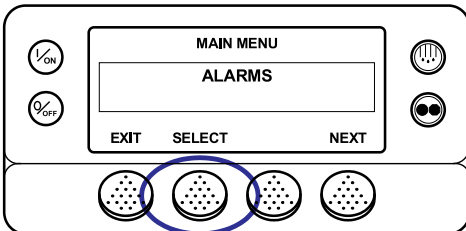

SAP289

The Alarm Display will appear. If no alarms are present, NO ALARMS will be shown.

THERMO KING

Operating Instructions

Figure 54. Alarms Menu

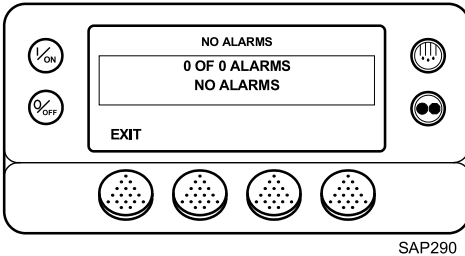

If alarms are present, the quantity of alarms (if more than one) and the most recent alarm code number will be shown. In the example below, there are two alarms present. The most recent is Alarm Code 6. It indicates a problem with the coolant temperature sensor.

Figure 55. Alarms Menu

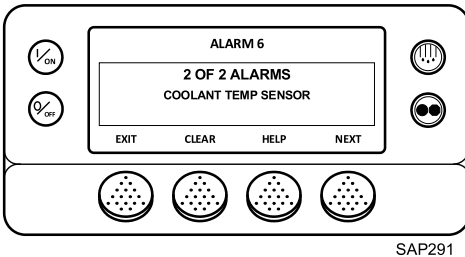

After the alarm situation is resolved, press the CLEAR Key to clear the alarm. For additional information regarding the alarm shown on the display, press the HELP Key. To display the next alarm, press the NEXT Key.

Figure 56. Clear, Help, Next Keys

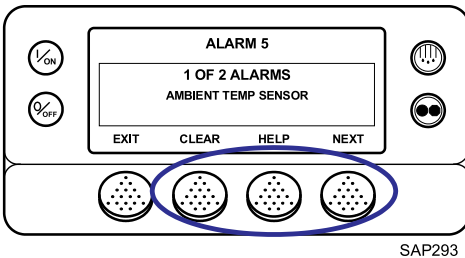

If a serious condition occurs, the unit will be shut down to prevent damage to the unit or the load. If this occurs, the display will show that the unit is shut down and display the alarm code that caused the shutdown. In the example shown below, the unit is shut down due to low oil level. For additional information regarding the alarm shown on the display, press the HELP Key.

Figure 57. Low Engine Oil Level Display

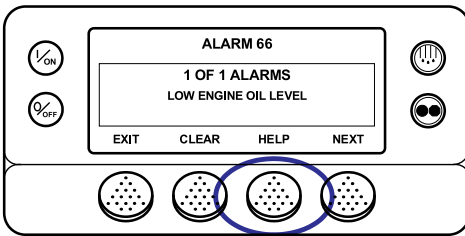

A help message will appear. For the alarm shown above, the message “CHECK OIL LEVEL. IF UNIT IS SHUT DOWN, REPAIR IMMEDIATELY. OTHERWISE, REPORT ALARM AT END OF THE DAY” will be shown on the display. Check the oil level and add oil as required, clear the alarm and restart the engine.

To select a different Main Menu item, press the NEXT Key. To return to the Standard Display, press the EXIT Key again.

Important: Always record any Alarm Codes that occur - in the order that they occur - as well as any other pertinent information. This information is extremely valuable to service personnel.

Important Alarm Notes

- If an alarm will not clear, it may still exist. If the alarm is not corrected, it will not clear or may be immediately set again.
- If an alarm cannot be cleared from the Main Menu, the Clear Key will not appear. These alarms must be cleared from the Maintenance or Guarded Access Menus.
- All alarms must be viewed before any of the alarms can be cleared.
- If optional Fuel Level Sensor is installed, Check Alarm Code 96 (Low Fuel Level) is set when the fuel level falls to 15%. The Base Controller can be programmed to set a shutdown Alarm Code 44 (Check Fuel System) when the fuel level falls to 5%. Shutdown Alarm Code 44 can be

Operating Instructions

manually cleared with the CLEAR key. In that case it becomes a check alarm and the unit will continue to run until it runs out of fuel (if it is not refilled). Alarm Code 96 and Alarm Code 44 are both automatically reset when the fuel tank is refilled above 25%.

Note: *Shutdown Alarm Code 44 reappears when it is manually cleared from the Alarms Menu. However, it changes to a check alarm so the unit will now start after you exit the Alarms Menu.*

- Contact your supervisor or a Thermo King dealer for information about alarm codes that will not clear.

Datalogger Menu

Initiating a Start of Trip

A “Start Of Trip” places a marker in the datalogger memory. It is typically initiated when the cargo is being loaded. The Start Of Trip marker then shows when the trip started in the data that is downloaded or printed from the datalogger. A Start Of Trip can be initiated through the use of WinTrac datalogging software, or manually in the field. The following procedure covers manual initiation. For more information on datalogging, see the WinTrac User Manual included with the WinTrac software.

1. Begin at the Standard Display. If the Temperature Watch Display is showing, press the MENU soft key once to return to the Standard Display.

Figure 58. Standard Display - Menu Key

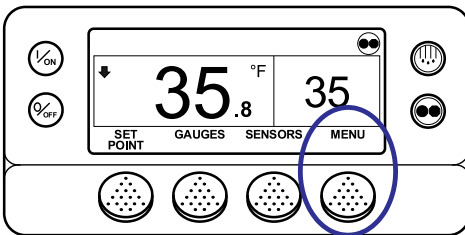

SAP249

2. Press the MENU soft key on the Standard Display.
3. Press the NEXT soft key until the Datalogger Menu appears.
4. Press the SELECT soft key on the Datalogger Menu. The “Start Trip” Screen will appear.

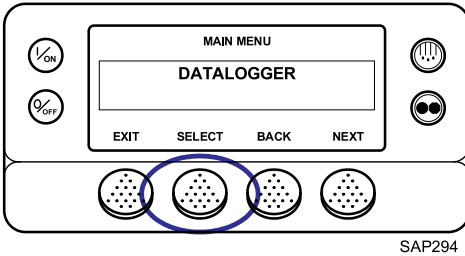
Figure 59. Main Menu - Data Logger

5. Press the SELECT soft key to initiate the Start of Trip. The display will briefly show START OF TRIP COMPLETE to confirm that a Start of Trip marker was set in the data logger.

Note: The start of trip marker is sent to both the CargoWatch/TouchPrint and ServiceWatch data loggers.

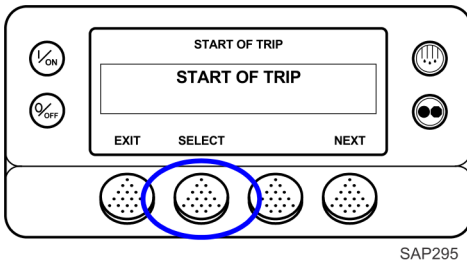
Figure 60. Start of Trip

Printing a Trip Report

This procedure shows how to connect a TouchPrint Printer, TouchPrint datalogger or equivalent to the SLX unit. The printed record shows things such as the unit and Base Controller identification numbers, dates and times, the setpoint, and the data from the optional sensors connected to the CargoWatch datalogger. If no sensors are connected, the printed record shows the same things without the sensor data.

Note: For additional information concerning the TouchPrint Printer or CargoWatch/TouchPrint Datalogger contact your Thermo King dealer.

1. Connect the printer to the 6-spliced wires located inside the control box.

Note: Contact your Thermo King dealer about printer connection location options.

Operating Instructions

2. Refer to the TK 56200-11-OP TouchPrint Operator Manual (or third party printer manual) for instructions for setup and use.

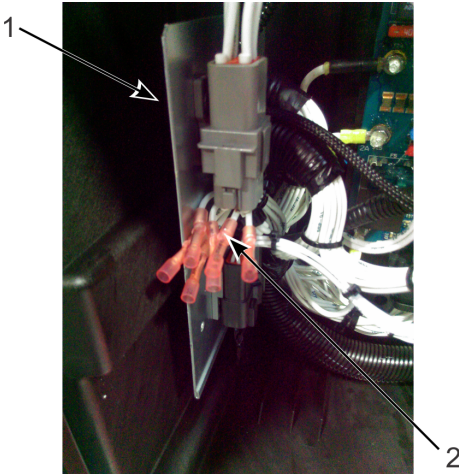

1	LVD Bracket
2	Printer Wire Splices

Hourmeters Menu

The Hourmeters are programmable to be visible or hidden in the Base Controller. Hourmeters that are visible are displayed. Hourmeters that are hidden are not displayed, but they do count hours. The default setting for Model 30 units is to display only the Engine Hours. The default setting for Model 50 units is to display Total Run Time Hours, Engine Hours, and Electric Run Hours. The Hourmeters Menu will not appear if all hourmeters are hidden. Contact your Thermo King dealer for information about programming the Base Controller.

Hourmeters are displayed using the Hourmeter Display. From the Standard Display, press the MENU Key ([Figure 61, p. 67](#)).

Figure 61. Menu Key

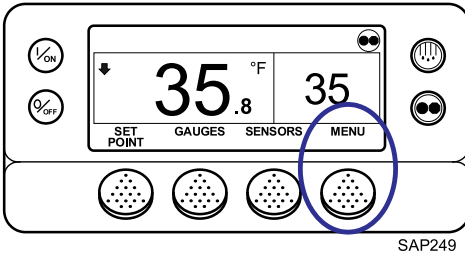

The Language Menu or Alarm Menu will appear. Press the NEXT Key as required to show the Hourmeter Menu ([Figure 62, p. 67](#)). When the Hourmeter Menu is shown press the SELECT Key. The Hourmeter Display will appear.

Figure 62. Main Menu - Hourmeters

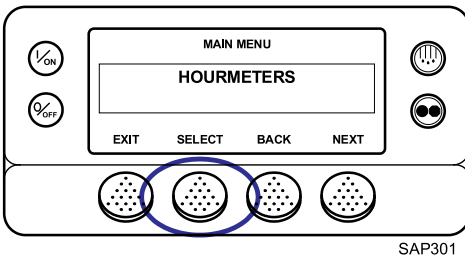

Press the NEXT or PREVIOUS Key to scroll through the hourmeters ([Figure 63, p. 67](#)).

Figure 63. Hourmeter Display

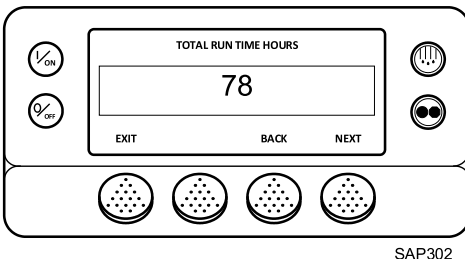

Mode Menu

Mode changes are made using the Mode Menu. From the Standard Display, press the MENU Key.

Figure 64. Menu Key

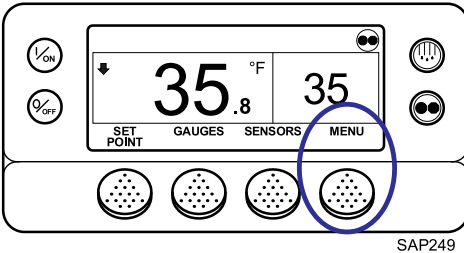

SAP249

The Language Menu or Alarm Menu will appear. Press the NEXT Key as required to show the Mode Menu. When the Mode Menu is shown, press the SELECT Key.

Figure 65. Main Menu - Mode

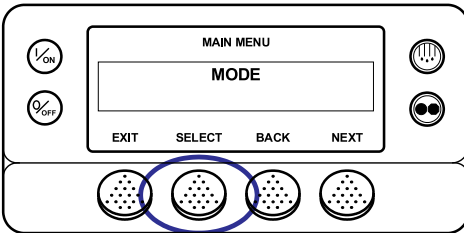

SAP303

The first enabled mode change screen will appear. To choose that function, press the SELECT Key. To Scroll through the enabled features in the Mode Menu, press the NEXT Key.

Figure 66. Change Mode

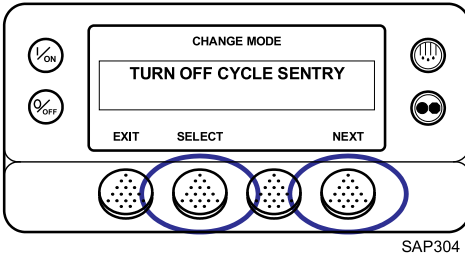

Various operating modes can be selected using the Mode Menu. Not all modes may be available, depending on OptiSet Plus usage and settings of other programmable features. To return to the Standard Display press the EXIT Key.

Turn Cycle Sentry On or Off

Cycle Sentry Mode can be turned On or Off if Cycle Sentry Mode is allowed by OptiSet Plus. If Cycle Sentry is turned off, the unit runs in Continuous Mode unless Continuous Mode is not allowed by OptiSet Plus. Either Cycle Sentry or Continuous operation can be disabled via OptiSet Plus. If the unit is running in Cycle Sentry Mode, press the SELECT Key to turn off Cycle Sentry Mode as shown below.

Figure 67. Turn Off Cycle Sentry

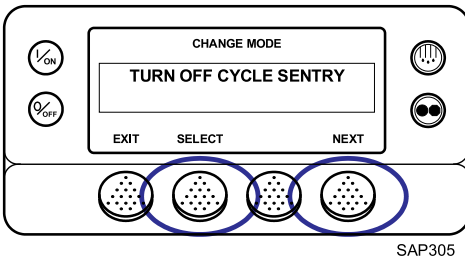

Confirmation screens will briefly appear, and the unit will switch to Continuous Mode operation. To turn Cycle Sentry back on press the SELECT Key again.

Note: Cycle Sentry Mode can also be turned on and off using the Cycle Sentry Key on the HMI Control Panel.

Figure 68. Turn On Cycle Sentry

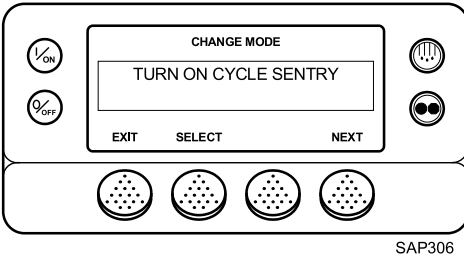

Select Temperature Units

If this feature is enabled in Guarded Access > Main Menu Configuration, the operator can select temperature units to be displayed as either degrees Fahrenheit or degrees Celsius. To change the temperature units from Fahrenheit to Celsius, press the SELECT Key as shown below.

Figure 69. Change Mode - Fahrenheit

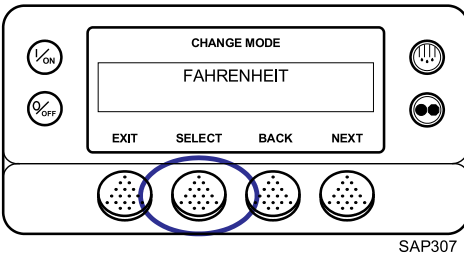

Press the "+" and "-" Keys to select the desired temperature units and press the YES Key to confirm.

Figure 70. Change Keys

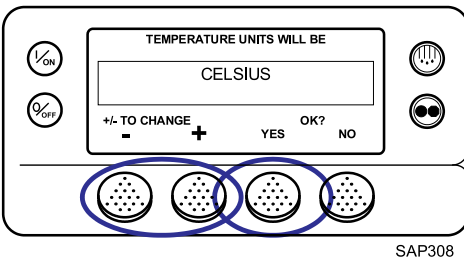

Confirmation screens will briefly appear, and the unit will display temperature units in Celsius. To return the display to Fahrenheit press the SELECT Key again.

Figure 71. Change Mode - Celsius

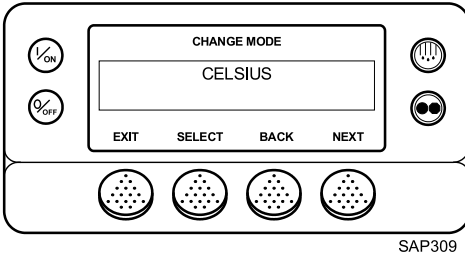

Keypad Lockout

If enabled in Guarded Access > Main Menu Configuration, the keypad can be locked to prevent unauthorized use. If the keypad is locked, only the On Key and Off Key function. The keypad will remain locked even if the unit is turned off and back on. If Keypad Lockout is active, press and hold any soft key for five seconds to deactivate the feature.

Start Sleep Mode

If this feature is enabled in Guarded Access > Main Menu Configuration, the operator can select and set Sleep Mode from the Mode Menu. Sleep Mode is used to keep the engine warm and the battery charged when the unit is not in use. When the unit is Sleep Mode, the display will show "SLEEP" and the current time.

Figure 72. Start Sleep Mode

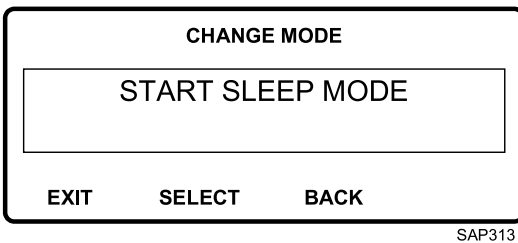

The following features are available in Sleep Mode. Follow the display prompts to select and set the features.

Operating Instructions

- Program Wakeup Time - This feature allows a wakeup time to be specified. When the selected time is reached, the unit will start and resume normal operation. If a Wakeup Time is selected, the following features are available:
 - Day to Wake Up - This feature allows the day the unit is to wake up to be specified.
 - Hour to Wake Up - This feature allows the hour the unit is to wake up to be specified.
 - Minute to Wake Up - This feature allows the minute the unit is to wake up to be specified.
 - Run Pretrip on Wakeup - This feature allows a Pretrip Test to be automatically run when the unit wakes up.

Pretrip

A Pretrip Test verifies unit operation. This display allows a Pretrip Test to be selected and initiated by the operator. If the Pretrip Test is entered with the unit shut down, a Full Pretrip Test with device amp checks will be performed. If the Pretrip Test is entered with the unit running in either diesel or electric mode, a Running Pretrip Test is performed. Test results are reported as PASS, CHECK, or FAIL when the Pretrip Test is completed.

Pretrip Test Conditions

- Current unit settings are saved and restored at the end of the Pretrip Test or if the unit is turned off and back on.
- A Pretrip Test can be run in either Diesel or Electric Mode.
- The unit will auto switch from Diesel Mode to Electric Mode or from Electric Mode to Diesel Mode during a Pretrip Test if these features are enabled and the auto switch conditions occur.

Conditions Where Pretrip Tests are Not Allowed

- If any Shutdown Alarms are present. Pretrip tests are allowed with some Check and Log Alarms.
- If the unit is in Sleep Mode.
- If the unit is in Service Test Mode, Interface Board Test Mode, or Evacuation Mode.

Pretrip Test Considerations

When performing a Pretrip Test, the following issues should be considered:

- If running a Pretrip Test on a trailer loaded with dry cargo, verify that proper airflow can occur around the load. If the load restricts airflow, false test results may occur. Also, these units have high refrigeration capacity which results in rapid temperature changes. Sensitive dry cargo may be damaged as a result.
- If running a Pretrip Test on a trailer that has just been washed down, the extremely high humidity inside the trailer may result in false test results.
- If running a Pretrip Test on a trailer loaded with sensitive cargo, monitor the load temperature during the test as normal temperature control is suspended during pre-trip operation.
- Always perform Pretrip Tests with the trailer cargo doors closed to prevent false test failures.

Pretrip Test Sequence

Pretrip tests proceed in the order shown below. A Full Pretrip Test includes all tests. A Running Pretrip Test is started with the engine or electric motor running and does not include the Amp Checks or Engine Start Check.

- **Amp Checks** - Each electrical control component is energized and the current drawn is confirmed as within specification.
- **Engine Start** - The Engine will start automatically.
- **Defrost** - If the coil temperature is below 45°F (7°C), a defrost cycle is initiated.
- **RPM Check** - The engine RPM in high and low speed is checked during the Cool Check.
- **Cool Check** - The ability of the unit to cool in low speed is checked.
- **Heat Check** - The ability of the unit to heat in low speed is checked.
- **Report Test Results** - The test results are reported as PASS, CHECK, or FAIL when the Pretrip Test is completed. If test results are CHECK or FAIL, alarm codes will exist to direct the technician to the source of the problem.

Performing a Pretrip Test

If a Pretrip Test is initiated with the engine shut down, a Full Pretrip Test will be performed. If a Pretrip Test is initiated with the engine or electric motor running, a Running Pretrip Test is performed.

Operating Instructions

- Before initiating a Pretrip Test, clear all alarm codes.
- To stop a Pretrip Test at any time, turn the unit off.

Pretrip Tests are initiated using the Pretrip Menu. From the Standard Display, press the MENU Key (Figure 73, p. 74).

Figure 73. Menu Key

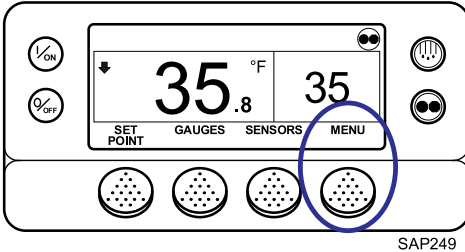

The Language Menu or Alarm Menu will appear. Press the NEXT Key as required to show the Pretrip Menu (Figure 74, p. 74). When the Pretrip Menu is shown, press the SELECT Key to start a Pretrip Test.

Figure 74. Pretrip Menu

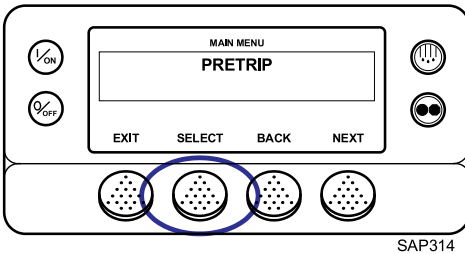

The display will briefly show PROGRAMMING PRETRIP MODE (Figure 75, p. 75). If the unit is not running, a Full Pretrip Test will be initiated. If the unit is running in either diesel or electric mode, a Running Pretrip will be performed.

Figure 75. Programming Pretrip Mode

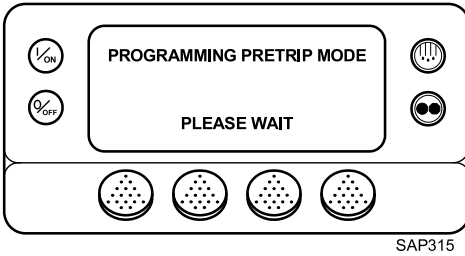

If all alarms were not cleared, a prompt appears as shown (Figure 76, p. 75). Exit the Pretrip Test, clear all alarms, and repeat the Pretrip Test.

Figure 76. Alarms Not Cleared

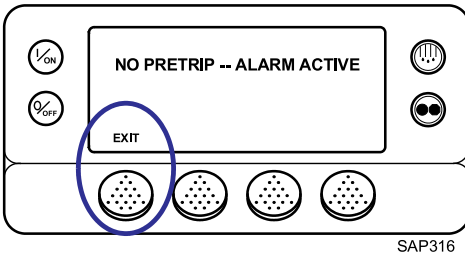

If all alarms were cleared, the Pretrip Test display appears (Figure 77, p. 75).

Figure 77. Pretrip Test

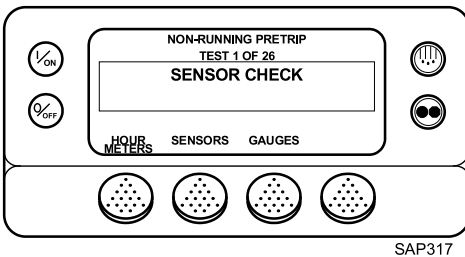

- The top line of the display indicates the unit is performing the non-running portion of the Pretrip Test.

Operating Instructions

- The second line measures test progress. The number of tests completed of the total number of tests to be performed is shown. In the example above, the unit is performing Test 1 of 26 Sensor Check.
- The soft keys may be used during the Pretrip Test to select the Hourmeter, Gauge, or Sensor Menus.
- To stop a Pretrip Test at any time, turn the unit off. This will generate Alarm Code 28 Pretrip Abort. Other alarm codes may also be generated. This is normal when the Pretrip Test is halted before completion.

When the non-running tests are complete, the unit will start automatically and continue with the Running Pretrip Test. In the example shown ([Figure 78, p. 76](#)), the unit is in the Running Pretrip and is performing Test 21 of 26 Cool Test.

Figure 78. Cool Test

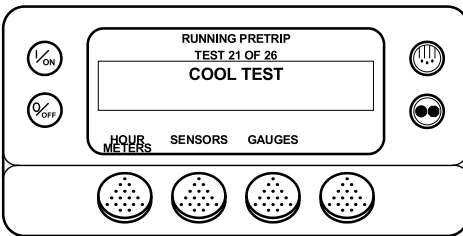

SAP318

When all tests are complete, the results are reported as PASS, CHECK, or FAIL ([Figure 79, p. 76](#)). If the results are CHECK or FAIL, the accompanying alarm codes will direct the technician to the cause of the problem.

Figure 79. Pretrip Pass

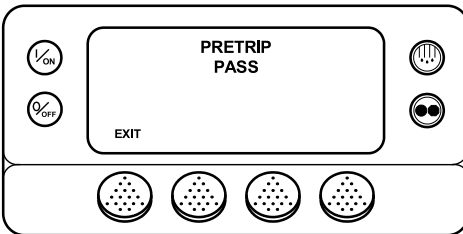

SAP319

If the Pretrip Test results are CHECK or FAIL, the problem should be diagnosed and corrected before the unit is released for service.

Adjust Brightness

The brightness of the HMI Control Panel display can be adjusted to allow for changing ambient light conditions. The choices available to the operator are HIGH, MEDIUM, LOW, and OFF. OFF actually results in a very dim screen suitable for low light conditions.

Important: Before replacing an HMI with no backlight, check the Adjust Backlight feature to verify the backlight is turned on.

Display brightness is adjusted using the Adjust Brightness Menu. From the Standard Display, press the MENU Key (Figure 80, p. 77).

Figure 80. Menu Key

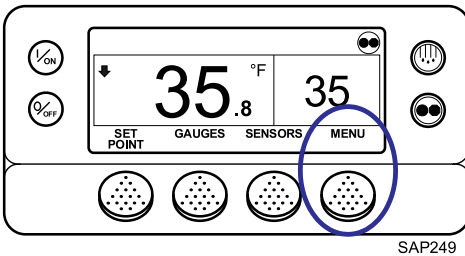

SAP249

The Language Menu or Alarm Menu will appear. Press the NEXT Key as required to show the Adjust Brightness Menu. When the Adjust Brightness Menu is shown press the SELECT Key (Figure 81, p. 77).

Figure 81. Adjust Brightness

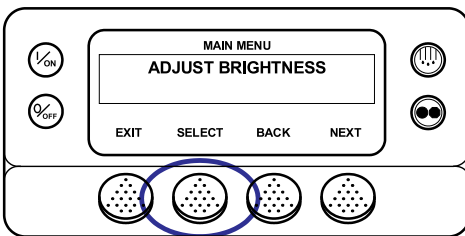

SAP322

The Display Brightness Menu will appear as shown (Figure 82, p. 78). Press the + or – Keys to select the desired display brightness. When the desired brightness is shown press the YES Key to confirm the choice.

Figure 82. Display Brightness Menu

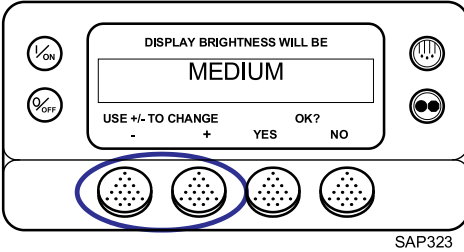

The display (Figure 83, p. 78) will briefly show ADJUSTING BRIGHTNESS - PLEASE WAIT.

Figure 83. Adjusting Brightness

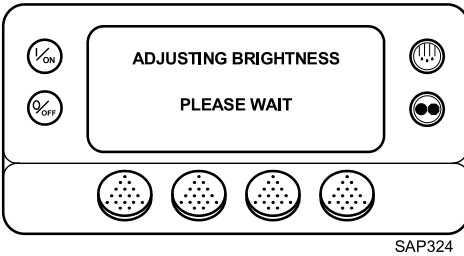

Time

The Time and Date held by the Base Controller can be checked. Time and Date cannot be changed from the Main Menu. The time and date is accessed using the Main Menu. From the Standard Display, press the MENU Key (Figure 84, p. 78).

Figure 84. Menu Key

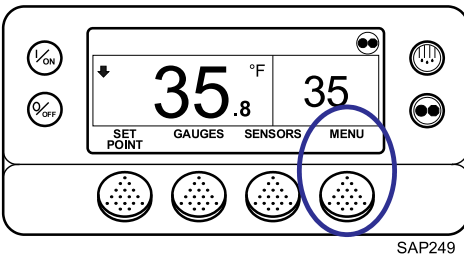

The Language Menu or Alarm Menu will appear. Press the NEXT Key as required to show the Time. When Time is shown press the SELECT Key. The current time and date will appear (Figure 85, p. 79).

Figure 85. Date and Time

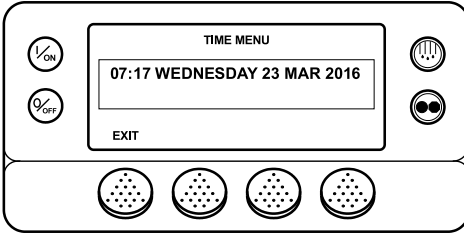

Alarm Codes

Introduction

An alarm code is generated when the microprocessor senses an abnormal condition. Alarms direct an operator or service technician to the source of a problem.

Multiple alarms can be present at one time. All generated alarms will be stored in memory until cleared by the operator. Document all alarm occurrences and report them to the service technician.

Refer to (“Alarms Menu,” p. 61) for information about viewing and clearing alarms.

Important: *Always record any Alarm Codes that occur - in the order that they occur - as well as any other pertinent information. This information is extremely valuable to service personnel.*

Notes:

1. *Some alarms (3, 4, 74, 203, and 204) cannot be cleared in the Alarms Menu, they must be cleared in the Maintenance Menu or the Guarded Access Menu. Contact your supervisor or a Thermo King dealer about clearing those alarms.*
2. *In some cases alarms cannot be cleared, or cannot be cleared after they have occurred a specified number of times. If such is the case, these alarms must be cleared by service personnel. Refer to (“Clearing Alarm Codes,” p. 83).*

Alarm Types

Log Alarm

Log Alarms are indicated for 30 seconds each time the unit is turned on. This level of alarm serves as a notice to take corrective action before a problem becomes severe. Maintenance items such as maintenance hourmeter time-outs are Log Alarms. The TemperatureWatch™ screen is not disabled if only Log Alarm(s) are active.

When the unit is turned on, the display will show the Thermo King Logo and then the “Configuring System” message. If Log Alarm(s) are present, the Log Alarm notice will appear on the display for 30 seconds. The remote indicator alarm light (if installed) will also be on during this period. After 30 seconds, the Standard Display will appear and the remote indicator alarm light will go off.

Note: The Alarm Icon does not appear on startup with Log Alarms present.

If only Log Alarms exist, the display shown (Figure 86, p. 81) will appear and the optional remote alarm light will illuminate for 30 seconds when the unit is turned on.

Figure 86. Log Alarms Exist

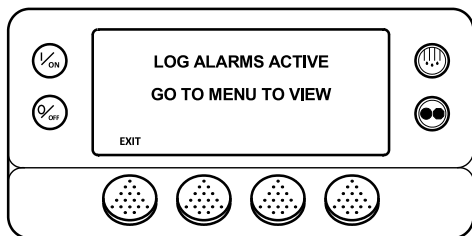

SAP312

Check Alarm

Check Alarms are indicated by a steady alarm indication at the top of the display and the message “Service Required within 24 Hours”. The Alarm Icon will appear. This level of alarm serves as a notice to take corrective action before a problem becomes severe. The unit will run with Check Alarms but some features and functions may be inhibited. The TemperatureWatch screen is disabled if a Check Alarm is active.

If a Check Alarm condition occurs while the unit is running, the alarm icon will appear in the display as shown (Figure 87, p. 81).

Figure 87. Alarm Icon

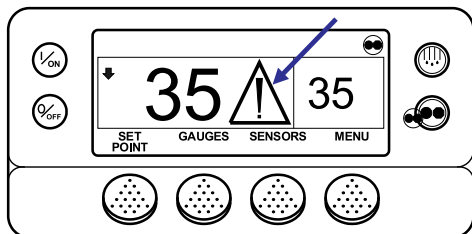

SAP286

Prevent Alarm

Prevent Alarms are indicated by a steady alarm indication at the top of the display and the message “Service Required within 24 Hours”. The Alarm

Alarm Codes

Icon will appear. The unit will be temporarily shut down if a Prevent Alarm is active. The unit will remain shut down for a timed restart interval or until the fault conditions are corrected and then restart. If the unit is in a temporary shutdown, Alarm Code 84 Restart Null will be present along with the associated Prevent Alarm. In most cases, the unit will restart with reduced performance to determine if continued operation is possible. If the alarm does not reoccur with reduced performance, the unit will return to full performance. If the unit is operating with reduced performance, Alarm Code 85 Forced Unit Operation will also be present under some conditions. In general, if the alarm condition reoccurs a defined number of times, the alarm is set as a Shutdown Alarm and no further restarts are possible. The TemperatureWatch screen is disabled if a prevent alarm is active.

Note: *If the Restart After Shutdown feature in the Guarded Access Menu is set for CONTINUOUS, an unlimited number of restart attempts are allowed.*

Shutdown Alarm

If a Shutdown Alarm occurs while the unit is running, it will be indicated by all of the following (Figure 88, p. 83):

- The Alarm Icon will appear.
- The display, backlight and optional remote alarm light will flash on and off.
- The display will switch from normal to inverted and back (light areas become dark and dark areas become light.)

Shutdown Alarms will force the unit into shutdown. The unit will remain in shutdown until the Shutdown Alarm is manually cleared. Exceptions are some engine and electric Shutdown Alarms that become Log Alarms when switched to the alternate operating mode (diesel to electric or electric to diesel). The TemperatureWatch screen is disabled if a unit level Shutdown Alarm is active.

Figure 88. Shutdown Alarm

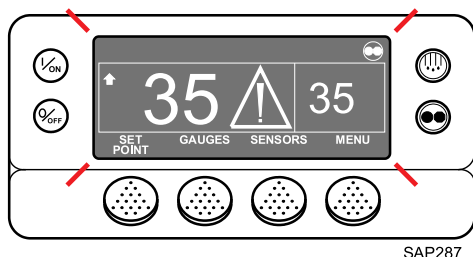

Pretrip Alarms

If an alarm occurs during a Pretrip Test, the alarm code will be displayed as Pretrip Alarm XX, where XX is the alarm code.

Low Battery Voltage

If Alarm Code 61 Low Battery Voltage is set as a Shutdown Alarm, no subsequent alarm codes will be set with the exception of Alarm Code 28 Pretrip Abort.

Alarm Codes When Switching Between Diesel and Electric

If a shutdown alarm occurs that affects only diesel mode operation and the unit is switched to electric, the diesel mode shutdown alarm becomes an electric mode log alarm. This allows the unit to run in electric mode without clearing the shutdown alarm that is preventing diesel mode operation. If the unit is switched back to diesel mode, the alarm again become a diesel mode shutdown alarm and prevents unit operation.

In the same manner, if a shutdown alarm occurs that affects only electric mode operation and the unit is switched to diesel, the electric mode shutdown alarm becomes a diesel mode log alarm to allow diesel mode operation. If the unit is switched back to electric mode, the alarm reverts to an electric mode shutdown alarm and prevents unit operation. If the unit is configured for electric to diesel Auto-Switch, it automatically starts and runs in diesel mode if an electric shutdown occurs.

Clearing Alarm Codes

Most alarm codes can be cleared conventionally from the Alarm Menu using the CLEAR Key.

Alarm Codes

The following control and display sensor alarm codes can only be cleared from the Maintenance Menu or Guarded Access Menu:

- Alarm Code 03 Check Control Return Air Sensor
- Alarm Code 04 Check Control Discharge Air Sensor
- Alarm Code 203 Check Display Return Air Sensor
- Alarm Code 204 Check Display Discharge Air Sensor
- Alarm Code 74 Controller Reset to Defaults.

The following alarm codes clear automatically:

- Alarm Code 64 Pretrip Reminder - Clears when a Pretrip Test is performed.
- Alarm Code 84 Restart Null - Clears when the unit is no longer in a restart null due to a Prevent Alarm.
- Alarm Code 85 Forced Unit Operation - Clears when the unit is no longer running in a forced mode due to a Prevent Alarm.
- Alarm Code 91 Check Electric Ready Input - Clears automatically when electric power is restored.
- Alarm Code 92 Sensor Grades Not Set - Clears when the sensor grade is changed from 5H.

The operator should contact a supervisor or a Thermo King dealer about clearing alarms using the Guarded Access Menu. Refer to (Table 1, p. 85) for alarm corrective action.

Note: Document all alarm faults and report them to the service technician.

There are three levels of corrective action that can be taken when an alarm condition occurs.

OK to Run: An alarm condition exists but does not affect unit operation. Corrective action can occur at a later date.

Check As Specified: An alarm condition exists that could affect unit operation. Follow directions in the Corrective Action column on the following chart.

Take Immediate Action: An alarm condition exists that will damage the unit or load. Take immediate action to correct the problem.

Note: The corrective actions listed in the Operating Instructions chapter and in Table 1, p. 85 are suggestions only. Always consult your company for final decisions.

Note: The following table shows all possible alarm codes for all possible applications. Not all codes will be applicable to each individual unit. Not all alarm codes are available with all microprocessor controllers or all revisions of software.

Table 1. Table of Alarm Codes

COLOR CODE DEFINITIONS:		OK TO RUN	CHECK AS SPECIFIED	TAKE IMMEDIATE ACTION
Num	Description	Operator Action		
00	No Alarms Exist	No action required.		
02	Evaporator Coil Sensor	Manually monitor load temperature with independent thermometer. Report alarm at end of day.		
03	Return Control Air Sensor	Manually monitor load temperature with independent thermometer. Report alarm at end of day.		
04	Discharge Control Air Sensor	Manually monitor load temperature with independent thermometer. Report alarm at end of day.		
05	Ambient Temperature Sensor	Report alarm at end of day.		
06	Engine Coolant Temp Sensor	Report alarm at end of day.		
07	Engine RPM Sensor	Report alarm at end of day.		
09	High Evaporator Temperature	Manually monitor load temperature. Report alarm at end of day.		
10	High Discharge Pressure	If unit is shut down, repair immediately. Otherwise, report alarm at end of day.		
11	Unit Controlling on Alternate Sensor	Manually monitor load temperature with independent thermometer. Report alarm at end of day.		
12	Sensor Shutdown	The unit is no longer able to operate and has been shut down. Repair immediately.		
13	Sensor Calibration Check	Manually monitor load temperature with independent thermometer. Report alarm at end of day.		
17	Engine Failed to Crank	If unit is shut down, repair immediately. Otherwise, report alarm at end of day.		

Alarm Codes

Table 1. Table of Alarm Codes (continued)

COLOR CODE DEFINITIONS:		OK TO RUN	CHECK AS SPECIFIED	TAKE IMMEDIATE ACTION
Num	Description	Operator Action		
18	High Engine Coolant Temperature			If unit is shut down, repair immediately. Otherwise, report alarm at end of day.
19	Low Engine Oil Pressure			If unit is shut down, repair immediately. Otherwise, report alarm at end of day.
20	Engine Failed to Start			If unit is shut down, repair immediately. Otherwise, report alarm at end of day.
21	Cooling Cycle Check			Manually monitor load temperature with independent thermometer. Report alarm at end of day.
22	Heating Cycle Check			Manually monitor load temperature with independent thermometer. Report alarm at end of day.
23	Cooling Cycle Fault			The unit is no longer able to operate and has been shut down. Repair immediately.
24	Heating Cycle Fault			The unit is no longer able to operate and has been shut down. Repair immediately.
25	Alternator Check			If unit is shut down, repair immediately. Otherwise, report alarm at end of day.
26	Check Refrigeration Capacity			Manually monitor load temperature with independent thermometer. Report alarm at end of day.
28	Pretrip or Self Check Abort			Report alarm at end of day.
29	Defrost Damper Circuit Check			If unit is shut down, repair immediately. Otherwise, report alarm at end of day.
30	Defrost Damper Stuck			If unit is shut down, repair immediately. Otherwise, report alarm at end of day.

Table 1. Table of Alarm Codes (continued)

COLOR CODE DEFINITIONS:		OK TO RUN	CHECK AS SPECIFIED	TAKE IMMEDIATE ACTION
Num	Description	Operator Action		
31	Check Oil Pressure Switch			If unit is shut down, repair immediately. Otherwise, report alarm at end of day.
32	Refrigeration Capacity Low			The unit is no longer able to operate and has been shut down. Repair immediately.
33	Check Engine RPM			Report alarm at end of day.
35	Check Run Relay Circuit			If unit is shut down, repair immediately. Otherwise, report alarm at end of day.
36	Electric Motor Failed to Run			If unit is shut down, repair immediately. Otherwise, report alarm at end of day.
37	Check Engine Coolant Level			Check engine coolant level. <u>Do not remove the cap if the engine is hot.</u> Report alarm at end of day.
38	Electric Phase Reversed			If unit is shut down, repair immediately. Otherwise, report alarm at end of day.
39	Check Water Valve Circuit			If unit is shut down, repair immediately. Otherwise, report alarm at end of day.
40	Check High Speed Circuit			If unit is shut down, repair immediately. Otherwise, report alarm at end of day.
41	Check Engine Coolant Temperature			If unit is shut down, repair immediately. Otherwise, report alarm at end of day.
42	Unit Forced to Low Speed			Report alarm at end of day.
43	Unit Forced to Low Speed Modulation			Report alarm at end of day.
44	Check Fuel System			Add fuel as necessary, otherwise report alarm at end of day.

Alarm Codes

Table 1. Table of Alarm Codes (continued)

COLOR CODE DEFINITIONS:		OK TO RUN	CHECK AS SPECIFIED	TAKE IMMEDIATE ACTION
Num	Description	Operator Action		
45	Check Hot Gas Bypass Circuit			If unit is shut down, repair immediately. Otherwise, report alarm at end of day.
46	Check Air Flow			If unit is shut down, repair immediately. Otherwise, report alarm at end of day.
48	Check Belts or Clutch			If unit is shut down, repair immediately. Otherwise, report alarm at end of day.
50	Reset Clock			Report alarm at end of day.
52	Check Heat Circuit			If unit is shut down, repair immediately. Otherwise, report alarm at end of day.
54	Test Mode Timeout			Service Test or Interface Board Test timed out after 15 minutes. Report alarm at end of day.
61	Low Battery Voltage			If unit is shut down, repair immediately. Otherwise, report alarm at end of day.
62	Ammeter Out of Calibration			If unit is shut down, repair immediately. Otherwise, report alarm at end of day.
63	Engine Stopped			If unit is shut down, repair immediately. Otherwise, report alarm at end of day.
64	Pretrip Reminder			Report alarm at end of day.
65	Abnormal Temperature Differential			If unit is shut down, repair immediately. Otherwise, report alarm at end of day.
66	Low Engine Oil Level			Check engine oil level. If unit is shut down, repair immediately. Otherwise, report alarm at end of day.
67	Check Liquid Line Solenoid			If unit is shut down, repair immediately. Otherwise, report alarm at end of day.

Table 1. Table of Alarm Codes (continued)

COLOR CODE DEFINITIONS:		OK TO RUN	CHECK AS SPECIFIED	TAKE IMMEDIATE ACTION
Num	Description	Operator Action		
68	Internal Controller Fault Code			Report alarm at end of day.
70	Hourmeter Failure			Report alarm at end of day.
74	Controller Reset to Defaults			Report alarm at end of day.
79	Internal Data Logger Overflow			Report alarm at end of day.
84	Restart Null			Report alarm at end of day.
85	Forced Unit Operation			Report alarm at end of day.
86	Check Discharge Pressure Sensor			Report alarm at end of day.
87	Check Suction Pressure Sensor			Report alarm at end of day.
89	Check Electronic Throttling Valve Circuit			If unit is shut down, repair immediately. Otherwise, report alarm at end of day.
90	Electric Overload			If unit is shut down, repair immediately. Otherwise, report alarm at end of day.
91	Check Electric Ready Input			If unit is shut down, repair immediately. Otherwise, report alarm at end of day.
92	Sensor Grades Not Set			Report alarm at end of day.
94	Check Loader #1 Circuit			If unit is shut down, repair immediately. Otherwise, report alarm at end of day.
95	Check Loader #1 Circuit			If unit is shut down, repair immediately. Otherwise, report alarm at end of day.
96	Low Fuel Level			Check engine fuel level and add fuel as required.
98	Check Fuel Level Sensor			Report alarm at end of day.
108	Door Open Timeout			Close doors. Report alarm at end of day.

Alarm Codes

Table 1. Table of Alarm Codes (continued)

COLOR CODE DEFINITIONS:		OK TO RUN	CHECK AS SPECIFIED	TAKE IMMEDIATE ACTION
Num	Description	Operator Action		
111	Unit Not Configured Correctly			Report alarm at end of day.
113	Check Electric Heat Circuit			If unit is shut down, repair immediately. Otherwise, report alarm at end of day.
114	Multiple Alarms - Can Not Run			If unit is shut down, repair immediately. Otherwise, report alarm at end of day.
117	Auto or Manual Switch from Diesel to Electric			Report alarm at end of day.
118	Auto or Manual Switch from Electric to Diesel			Report alarm at end of day.
120	Check Alternator Excite Circuit			If unit is shut down, repair immediately. Otherwise, report alarm at end of day.
121	Check PWM/Liquid Injection Circuit			If unit is shut down, repair immediately. Otherwise, report alarm at end of day.
122	Check Diesel/Electric Circuit			If unit is shut down, repair immediately. Otherwise, report alarm at end of day.
127	Setpoint Not Entered			Verify setpoint is adjusted to required temperature.
128	Engine Run Time Maintenance Reminder # 1			Report alarm at end of day.
129	Engine Run Time Maintenance Reminder # 2			Report alarm at end of day.
130	Electric Run Time Maintenance Reminder # 1			Report alarm at end of day.
131	Electric Run Time Maintenance Reminder # 2			Report alarm at end of day.
132	Total Unit Run Time Maintenance Reminder # 1			Report alarm at end of day.
133	Total Unit Run Time Maintenance Reminder # 2			Report alarm at end of day.

Table 1. Table of Alarm Codes (continued)

COLOR CODE DEFINITIONS:		OK TO RUN	CHECK AS SPECIFIED	TAKE IMMEDIATE ACTION
Num	Description	Operator Action		
134	Controller Power On Hours	Report alarm at end of day.		
135	Check Spare Digital Inputs	Report alarm at end of day.		
136	Check Spare Digital Outputs	Report alarm at end of day.		
137	Damper Gear Motor Heater	Report alarm at end of day.		
141	Auto-Switch Diesel to Electric Disabled	Report alarm at end of day.		
145	Loss of Controller "On" Feedback Signal	If unit is shut down, repair immediately. Otherwise, report alarm at end of day.		
146	Software Version Mismatch	If unit is shut down, repair immediately. Otherwise, report alarm at end of day.		
148	Auto-Switch Electric to Diesel Disabled	Report alarm at end of day.		
149	Alarm Not Identified	If unit is shut down, repair immediately. Otherwise, report alarm at end of day.		
150	Out of Range Low (HMI)	Manually monitor load temperature. Report alarm at end of day.		
151	Out of Range High (HMI)	Manually monitor load temperature. Report alarm at end of day.		
157	OptiSet File Mismatch	Manually monitor load temperature. Report alarm at end of day.		
158	Primary (New) Software Failed to Load	Report alarm at end of day.		
159	Check Battery Condition	If unit is shut down, repair immediately. Otherwise, report alarm at end of day.		
203	Check Display Return Air Sensor	Manually monitor load temperature. Report alarm at end of day.		

Alarm Codes**Table 1. Table of Alarm Codes (continued)**

COLOR CODE DEFINITIONS:		OK TO RUN	CHECK AS SPECIFIED	TAKE IMMEDIATE ACTION
Num	Description	Operator Action		
204	Check Display Discharge Air Sensor	Manually monitor load temperature. Report alarm at end of day.		
252	Auto Fresh Air Exchange Door (AFAED)	Report alarm at end of day.		

Loading and Inspection Procedures

This chapter describes pre-loading inspections, loading procedures, post-loading procedures, post-loading inspections, and enroute inspections. Thermo King refrigeration units are designed to maintain the required product load temperature during transit. Follow these recommended loading and enroute procedures to help minimize temperature related problems.

Note: *When in doubt as to the correct refrigeration requirements and/or loading procedures, call your company office for instructions.*

Pre-Loading Inspection

1. Pre-cool products before loading. Note any variances on the manifest.
2. Inspect door seals and vent doors for condition and a tight seal with no air leakage.
3. Inspect the trailer inside and out. Look for:
 - Damaged or loose trailer skin and insulation
 - Damaged walls, air ducts, floor channels, or “T” flooring
 - Clogged defrost drain tubes
 - Blocked return air bulkhead
4. Verify that the setpoint temperature is correct for your cargo. Pre-cool the trailer as required.
5. Supervise product loading to ensure sufficient air space around and through the load. Airflow around cargo must not be restricted.

Note: *If the warehouse is not refrigerated, operate the unit with the doors closed until cargo is ready to be loaded. Then turn off the unit, open the cargo doors and load cargo. When cargo is loaded, close trailer doors and restart the unit. The unit can be operated with the cargo box doors open if the truck is backed into a refrigerated warehouse and the dock door seals fit tightly around the trailer.*

Figure 89. Loading Considerations

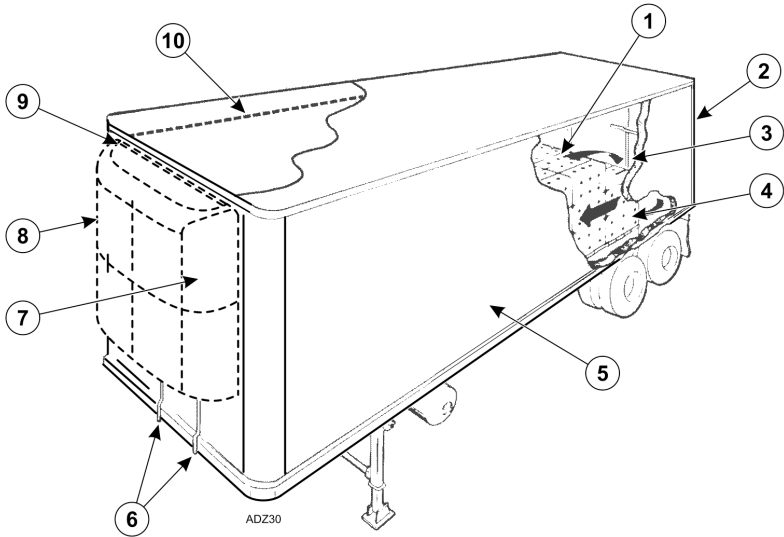

1.	Correct load height (trailers without chutes)	6.	Clear defrost drains
2.	Tight doors and seals	7.	Good outside air circulation
3.	Good air circulation around load	8.	Unit inspection
4.	Proper cargo temperature (prior to loading)	9.	Tight seals
5.	Interior/exterior walls and insulation in good condition	10.	Maximum load height followed

Post-Loading Inspection

Post-loading inspections verify the cargo has been loaded properly. To perform a post-load inspection:

1. Inspect the evaporator outlets for blockage.
2. Turn the unit off before opening the cargo box doors to maintain efficient operation.

Loading and Inspection Procedures

Note: *The unit can be operated with the cargo box doors open if the truck is backed into a refrigerated warehouse and the dock door seals fit tightly around the trailer.*

3. Perform a final check of the load temperature. If the load is above or below temperature, make a final notation on the manifest.

Important: *Cargo must be pre-cooled to proper temperature before loading. The unit is designed to maintain temperature, not cool an above-temperature load.*

4. Close or supervise the closing of the cargo box doors. Verify they are securely locked.
5. Verify the setpoint is at the temperature listed on the manifest.
6. If the unit was stopped, restart using the correct starting procedure. See the Operating Instruction chapter in this manual.
7. Start a manual defrost cycle 30 minutes after loading. See the Manual Defrost procedure in the manual.

Enroute Inspections

Complete the following enroute inspection every four hours. This will help minimize temperature related problems.

Inspection Procedure

1. Verify setpoint is correct.
2. Check the return air temperature reading. It should be within the desired temperature range.
3. Initiate a manual defrost cycle after each enroute inspection.

Inspection Troubleshooting

1. If a temperature reading is not within the desired temperature range, refer to the troubleshooting table ([Table 2, p. 96](#)). Correct problem as required.
2. Repeat the Enroute Inspection every 30 minutes until the compartment temperature is within the desired temperature range. Stop the unit if the compartment temperature is not within the desired temperature range on two consecutive 30 minute inspections, especially if the compartment temperature appears to be moving away from the setpoint.
3. Immediately contact the nearest Thermo King Service Center or your company office.

Loading and Inspection Procedures

- Take all necessary steps to protect and maintain proper load temperature.

NOTICE

Cargo Loss!

Stop the unit if the compartment temperature remains higher than the desired temperature range from the setpoint on two consecutive 30 minute inspections. Contact the nearest Thermo King Service Center or your company office immediately. Take all necessary steps to protect and maintain proper load temperature.

Table 2. Inspection Troubleshooting

Problem: A return air temperature reading is not within desired temperature range of the setpoint.	
Cause	Remedy
The unit has not had time to cool down to correct temperature.	Refer to the load log history. Look for above temperature load records, properly pre-cooled cargo compartment, length of time on road, etc. Correct as required. Continue monitoring return air temperature until the reading is within the desired temperature range of the setpoint.
The unit may have a low refrigerant charge.	Check the receiver tank sight glass for refrigerant level. If fluid is not showing in the receiver tank sight glass, the refrigerant charge may be low. A competent refrigeration technician is required to add refrigerant or repair the system. Contact the nearest Thermo King dealer, authorized Service Center, or call the Thermo King Cold Line for referral. Consult the Table of Contents for Cold Line information.
The unit is in defrost or has just completed a defrost cycle.	Monitor the return air temperature after the defrost cycle is completed to see if the temperature returns to the desired temperature range of the setpoint.
The evaporator is plugged with frost.	Initiate a manual defrost cycle. The defrost cycle will automatically terminate when complete. Continue monitoring the return air temperature until the reading is within the desired temperature range of the setpoint.
Improper air circulation in the cargo compartment.	Inspect the unit and cargo compartment to determine if the evaporator fan (3) are working properly circulation the air. Poor air circulation may be due to improper loading of the cargo, shifting of the load, or depending on unit, fan belt slippage or faulty electrical fans. Correct as required. Continue monitoring return air temperature until problem is corrected.

Loading and Inspection Procedures

Table 2. Inspection Troubleshooting (continued)

Problem: A return air temperature reading is not within desired temperature range of the setpoint.	
Cause	Remedy
The unit did not start automatically.	Determine the cause for not starting. Correct as required. Continue monitoring return air temperature until reading is within desired temperature range of the setpoint.

Jump Starting

If unit battery is discharged or run down, unit may be jump started using jumper cables and another battery or vehicle. Consider the following precautions and be careful when jump starting a unit.

⚠ WARNING

Personal Protective Equipment (PPE) Required!

A battery can be dangerous. A battery contains a flammable gas that can ignite or explode. A battery stores enough electricity to burn you if it discharges quickly. A battery contains battery acid that can burn you. Always wear goggles or safety glasses and personal protective equipment when working with a battery. If you get battery acid on you, immediately flush it with water and get medical attention.

⚠ CAUTION

Hazard of Explosion!

Unhook the semi tractor from the trailer before using the tractor to jump start the unit on the trailer. The negative ground circuit is complete when the tractor is hooked to the trailer. This can cause dangerous sparks when the positive connection is made at the battery.

Important: *Make sure to use a 12 volt battery to jump start unit. If you are using a vehicle, make sure it has a 12 volt battery with a negative ground system. Do not use a "hot shot" booster device or a 24 volt source.*

Read and understand the following procedure completely before connecting and jumper cables. Use good jumper cables made with #2 gauge (or larger) cables.

1. Verify unit is turned off. If you are using a vehicle, verify its ignition is also turned off.
2. Open front doors on unit. Battery is located on the right of engine.
3. Check discharged battery to verify it is not damaged or frozen. Do not jump start a damaged or frozen battery. Check vent caps to verify they are tight.
4. Identify positive (+) and negative (-) battery terminals.
5. Remove red cover from positive (+) battery terminal on the unit's battery.

Figure 90. Sequence for Connecting Jumper Cables

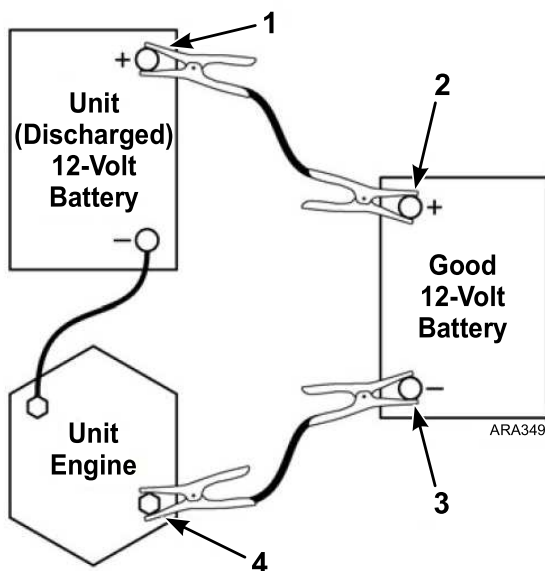

1.	Positive (+) Terminal on Unit Battery
2.	Positive (+) Terminal on Good Battery
3.	Negative (-) Terminal on Good Battery
4.	Starter Mounting Bolt on Unit Engine

6. Connect the red positive (+) jumper cable to the positive (+) battery terminal on the unit's battery. Do not let the other end of the jumper cable touch anything that conducts electricity.

⚠ WARNING

Hazard of Explosion!

Allowing the positive (+) jumper cable to short to ground can produce dangerous sparks.

7. Connect the other end of the red positive (+) jumper cable to the positive (+) battery terminal on the good battery.

Jump Starting

8. Connect the black negative (-) jumper cable to the negative (-) battery terminal on a good battery. Do not let the other end of the jumper cable touch anything that conducts electricity.
9. Connect the black negative (-) jumper cable to the lower starter mounting bolt on the unit's engine.
10. If you are using a vehicle to jump start the unit, start the vehicle and let it run for a few minutes. This will help charge the discharged battery.

⚠ DANGER

Risk of Injury!

Keep your hands, clothing, and tools clear of fans and/or belts when working on a unit that is running or when opening or closing compressor service valves. Loose clothing might entangle moving pulleys or belts, causing serious injury or possible death.

11. Turn the unit on and let it start automatically or start it manually. If the unit will not crank or start, contact a qualified technician.
Note: Some units with microprocessors will show an alarm code and will not try to start the unit until battery voltage is above 10 volts.
12. After the unit starts, remove the jumper cables in reverse order: black negative (-) from the unit starter mounting bolt, black negative (-) from the good battery, red positive (+) from the good battery, and red positive (+) from the unit battery (that was discharged).

Figure 91. Sequence for Disconnecting Jumper Cables

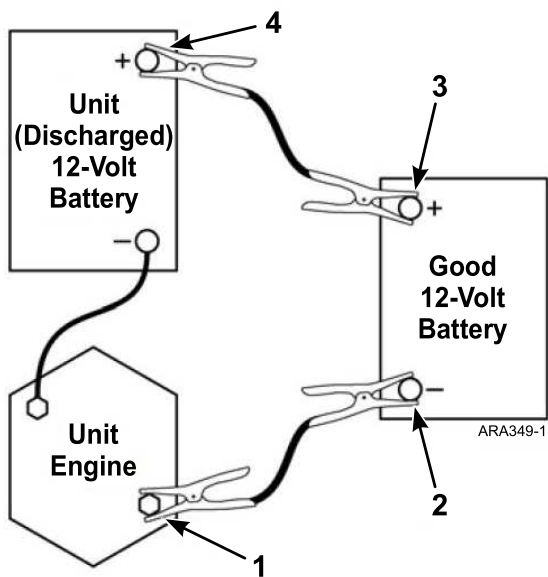

1.	Starter Mounting Bolt on Unit Engine
2.	Negative (-) Terminal on Good Battery
3.	Positive (+) Terminal on Good Battery
4.	Positive (+) Terminal on Unit Battery

Specifications

Engine

<p>Important: <i>New diesel engine models started being installed in units beginning the 4th quarter of 2020. Some engine components along with maintenance and inspection procedures are different between engine models. Refer to the information located on top of the engine to determine which model engine is in your unit, or contact your Thermo King Dealer for assistance.</i></p>	
Model	TK486V25X changed to TK486V25X1 2nd quarter 2021.
Fuel Type	No. 2 diesel fuel under normal conditions No. 1 diesel fuel is acceptable cold weather fuel
Oil Capacity	13 quarts (12.3 liters/litres) crankcase and oil filter Fill to full mark on dipstick
Oil Type	Requires API Classification CJ-4 or CK-4 ACEA Rating E6
Recommended oil viscosity based on ambient temperature	14 F to 122 F (-10 C to 50 C): SAE 15W-40 (Synthetic) 5 to 104 F (-15 to 40 C): SAE 15W-40 5 to 104 F (-15 to 40 C): SAE 10W-30 (Synthetic or Synthetic Blend) -13 to 104 F (-25 to 40 C): SAE 10W-40 -13 to 86 F (-25 to 30 C): SAE 10W-30 -22 to 122 F (-30 to 50 C): SAE 5W-40 (Synthetic) Below -22 F (-30 C): SAE 0W-30 (Synthetic)
Engine Coolant Type	Chevron/Delo XLC (Havoline XLC for Europe) - a nitrite-free Extended Life Coolant (ELC) Use a 50/50 concentration
<div style="background-color: black; color: white; padding: 5px; font-weight: bold; font-size: 1.2em;">NOTICE</div> <div style="border: 1px solid black; padding: 5px; margin-top: 5px;"> <p>System Contamination!</p> <p>Do not add other types of coolant to cooling systems using Chevron/Delo XLC except in an emergency. If another type of coolant is added, the coolant must be changed to Chevron/Delo XLC when available.</p> </div>	
Coolant System Capacity	7.0 quarts (6.6 liters)

Radiator Cap Pressure	7 psig (48.3 kPa)
Engine Coolant Thermostat	160 F (71 C)

Refrigeration System

Contact your Thermo King dealer for refrigeration system service or maintenance.

Electrical Control System

Low Voltage	12.8 Vdc Nominal
Battery	Thermo King EON (880 CCA) AGM battery as standard - recommended for extreme climates and for Rail Ready (RR), Domestic Refrigerated Container (DRC), and Trailer on Flat Car (TOFC) applications. Note: <i>If the unit is not going to be used for an extended period of time, turn the Microprocessor On/Off Power Switch to the OFF position to maximize battery life.</i>
Fuses	Refer to Fuses (" Unit Protection Devices ," p. 24).
Battery Charging	12 volt, 37 amp, brush type, Thermo King Alternator.

TrackKing® ConnectedSuite™

Platform	ARM Cortex-A8, 300MHz, 256MB RAM, 4GB Flash, Linux
GSM/GPRS	3G, Sierra HL8548
GPS	u-blox NEO-7M
Bluetooth®	Version 4.0 Bluetooth Classic /Bluetooth Low Energy (BLE)
Serial Ports	2 External Serial Ports for TrackKing extensions or Third-Party Connect
Input Power	12.0 Vdc Nominal

Specifications

Backup Battery	Single cell Li-Ion 3.7V Nominal, > 2Ah
Environmental Storage Temperature	-40 to + 85°C

Maintenance Inspection Schedule

Pretrip	Every 1,500 Hours	Every 3,000 Hours*	Annual/ 4,500 Hours	Inspect/Check/Service These Items
				Microprocessor
•				Run Pretrip Test (" Performing a Pretrip Test, " p. 73).
				Engine
•	•	•	•	Check fuel supply.
•	•	•	•	Check engine oil level.
•	•	•	•	Inspect belts for condition and proper tension.
•	•	•	•	Inspect all belt tensioners and belt idler pulleys for condition and correct operation. Lubricate as needed.
•	•	•	•	Check engine oil pressure hot, on high speed (should display "OK").
•	•	•	•	Listen for unusual noises, vibrations, etc.
		•	•	Visually inspect exhaust system for leakage and abnormal smoke or particulate emissions.
•	•	•	•	Check engine coolant level and antifreeze protection (-30 F [-40 C]).
	•	•	•	Drain water from fuel tank and check vent.
	•	•	•	Inspect/clean fuel transfer pump inlet strainer.
	•	•	•	Check and adjust engine speeds (high and low speed).
	•	•	•	Check condition of drive coupling bushings in accordance with Service Bulletin TT171.
	•			Inspect air filter element - Dependent on operating conditions, assess fitness to continue to next service.

Maintenance Inspection Schedule

Pretrip	Every 1,500 Hours	Every 3,000 Hours*	Annual/ 4,500 Hours	<p style="text-align: center;">Inspect/Check/Service These Items</p>
			•	
		•		Replace EMI 3000 air cleaner element at 3,000 hours or two years (whichever occurs first).
		•		Replace EMI 3000 fuel filter/water separator.
		•		Change engine oil and oil filter (hot). Requires oil with API Classification CJ-4 or CK-4 (ACEA Rating E9).
		•		Adjust engine valve clearance.
		•		Test fuel injection nozzles at least every 3,000 hours. Based on EPA 40 CFR Part 89.
			—	Replace all belts every 6,000 hours or every 48 months (whichever occurs first).
			—	Change ELC (red) engine coolant every 5 years or 12,000 hours. Units equipped with ELC have an ELC nameplate on the expansion tank (see "Engine Cooling System").
			—	Replace fuel return lines between fuel injection nozzles every 10,000 hours.
				Electrical
•	•	•	•	Check operation of defrost damper (closes on defrost initiation and opens on defrost termination).
	•	•	•	Inspect battery terminals.
	•	•	•	Inspect wire harness for damaged wires or connections.
		•	•	Inspect alternator wire connections for tightness and for corrosion.
		•	•	Inspect alternator brushes.

Maintenance Inspection Schedule

Pretrip	Every 1,500 Hours	Every 3,000 Hours*	Annual/ 4,500 Hours	
				Inspect/Check/Service These Items
			—	Change alternator brushes and regulator at 6,000 hours.
				Refrigeration
	•	•	•	Visually inspect condenser/radiator and evaporator coils for damage and dirt ingress.
•	•	•	•	Check refrigerant level.
	•	•	•	Check for proper suction and discharge pressures and ETV operation.
	•	•	•	Check compressor oil level and condition.
			•	Check compressor efficiency and pump down refrigeration system.
		•		Replace dehydrator and check discharge and suction pressure every two (2) years or 3,000 hours.
				Structural
•	•	•	•	Visually inspect unit for fluid leaks.
•	•	•	•	Visually inspect unit for damaged, loose, or broken parts (includes air ducts and bulkheads).
	•	•	•	Inspect cross shaft, fanshaft, and idlers for bearing wear (noise).
	•	•	•	Clean entire unit including condenser and evaporator coils and defrost drains.
	•	•	•	Check all unit and fuel tank mounting bolts, brackets, lines, hoses, etc.
* 3,000 hours or two years, whichever occurs first.				

Emergency Cold Line

If you can't get your unit operating and need assistance, you can locate a Thermo King Dealer anywhere in the United States by going to thermoking.com or by using the Thermo King North American Service Directory (available from any Thermo King dealer). If you are unable to reach a dealer, then call the Toll Free Emergency Cold Line Number (888) 887-2202. The answering service will assist you in reaching a dealer to get the help you need. The Cold Line is answered 24 hours a day by personnel who will do their best to get you quick service at an authorized Thermo King Dealer



RCS358

Warranty

Please contact your nearest Thermo King dealer for terms of the Thermo King North American Trailer Unit Limited Warranty. Refer to TK 56445-9-CH.

EPA and ARB Supplemental Emissions Warranty Statement

Your Thermo King unit is covered by the diesel engine manufacturer's EPA and ARB Supplemental Emissions Warranty. Complete details of this emission warranty can be found at www.thermoking.com.

CALIFORNIA Proposition 65 Warning



RCS1032

Thermo King – by Trane Technologies (NYSE: TT), a global climate innovator – is a worldwide leader in sustainable transport temperature control solutions. Thermo King has been providing transport temperature control solutions for a variety of applications, including trailers, truck bodies, buses, air, shipboard containers and railway cars since 1938. For more information, visit www.thermoking.com or www.tranetechnologies.com.

Thermo King has a policy of continuous product and product data improvements and reserves the right to change design and specifications without notice. We are committed to using environmentally conscious print practices.