



THERMO KING

Installation Manual

Trailer Edition
Heat King 450 Series
HK450, HK450 HO and HK450 MAX
Diesel Heating Units
TK 56118-6-IM (Rev. 1, 05/15)

Installation Manual

Trailer Edition Heat King 450 Series

HK450, HK450 HO and HK450 MAX Diesel Heating Units

TK 56118-6-IM (Rev. 1, 05/15)

Release History

Released 05/15

Rev. 1 05/15 Page10: Updated unit weights, pages 18-19: Added drain hose installation instructions (HK450 MAX only).

Introduction

This installation manual was written to assist with the installation of the **Thermo King Heat King 450 Series** transport heaters onto trailers or intermodal containers specifically designed and built for these applications. Separate installation instructions for the various fuel tanks and factory options available for the HK unit are located at Thermo King iService or Thermoking.com.

Due to its complexity, you should not attempt this installation unless you:

- Are an experienced mechanic
- Can safely lift 34 kilos (75 lbs.)
- Are certified or trained in the repair and maintenance of diesel powered refrigeration systems
- Have a basic understanding of electricity and electrical wiring
- Have the necessary tools and equipment to complete the installation.

This manual is published for informational purposes only. Thermo King makes no representations warranties express or implied, with respect to the information recommendations and descriptions contained herein. Information provided should not be regarded as all-inclusive or covering all contingencies. If further information is required, Thermo King Corporation Service Department should be consulted.

Thermo King's warranty shall not apply to any equipment which has been "so installed, maintained, repaired or altered as, in the manufacturer's judgment, to affect its integrity."

Manufacturer shall have no liability to any person or entity for any personal injury, property damage or any other direct, indirect, special, or consequential damages whatsoever, arising out of the use of this manual or any information, recommendations or descriptions contained herein.

Table of Contents

Introduction	3	Battery Selection Guide	16
Safety Precautions	5	Group 31 Battery Dimensions	17
Required Tools	7	Installing the Unit - Standard Installation	18
Installation Components	8	Installing the Remote HMI	20
Trailer / Container Requirements	10	Installing the Fuel Pump and Fuel Lines	22
Mounting Bolt Specifications and Installation Requirements	12	Installing the Battery	26
Unit Dimensions	14	Service Test Procedure	28
HMI Remote Mount Dimensions	15	SYSTEM CHECK LIST	30

Safety Precautions

The  symbol appears next to a point that is particularly important:

 **DANGER:** Addresses a circumstance that, if encountered, will lead to death or serious injury

 **WARNING:** Addresses a circumstance that, if encountered, might lead to death or serious injury.

 **CAUTION:** Addresses a circumstance that, if encountered, may cause damage to equipment or minor injury.

 **WARNING:** Keep your hands away from fans and belts when the unit is running. Set all electrical controls to the OFF position before servicing the unit.

 **WARNING:** Make sure all mounting bolts are tight and are of correct length for their particular application







 **WARNING:** Never drill holes in the unit unless absolutely necessary. Holes drilled into the unit may weaken structural components. Holes drilled into electrical wiring can cause fire or explosion.

 **WARNING:** When using ladders to install or service refrigeration systems, always observe the ladder manufacturer's safety labels and warnings. A work platform is the recommended method for installations.

 **CAUTION:** Exposed coil fins are very sharp and can cause painful lacerations. Wear leather work gloves to prevent injury.

Safety Precautions (continued)

Battery Installation and Cable Routing

-  **WARNING:** *Improperly installed battery could result in a fire or explosion! A Thermo King approved battery must be installed and properly secured to the battery tray.*
-  **WARNING:** *Improperly installed battery cables could result in fire or explosion! Battery cables must be installed, routed and secured properly to prevent them from rubbing, chaffing or making contact with hot, sharp or rotating components.*
-  **WARNING:** *Do not attach fuel lines or any additional wiring harnesses to the battery cables as this could cause an electrical fire!*
-  **CAUTION:** *Do not connect other manufacturer's equipment or accessories to the Thermo King unit. This could result in severe damage to equipment and void the warranty!*
-  **CAUTION:** *Set all unit electrical controls to the OFF position before connecting battery cables to the battery to prevent unit from starting unexpectedly and causing personal injury.*
-  **CAUTION:** *Always wear protective clothing, gloves and eye wear when handling and installing batteries. Battery acid can cause serious burns when exposed to eyes or skin. If battery acid contacts skin or clothing, wash immediately with soap and water. If acid enters your eye, immediately flood it with running cold water for at least twenty minutes and get medical attention immediately.*
-  **CAUTION:** *Always cover battery terminals to prevent them from making contact with metal components during battery installation. Battery terminals grounding against metal could cause the battery to explode.*

Required Tools

1. Safety Glasses
2. Drill
3. Drill Bits
4. Tape Measure
5. Mechanics Tools
6. Lifting Device
7. Two Forged Eyebolts (1/2-13 UNC)
8. Work Platform (Recommended)
9. Torque Wrench

NOTE: Equipment such as torque wrenches should be in good working condition and routinely calibrated to assure accurate readings.

Installation Components

HARDWARE KIT

Clamps
Bandwraps
Screw 1/4-20 SS
Nut 1/4-20 SS
Nut 1/2-13
Washer 1/2- SAE
Washer 1/4 SS
Washer 1.25 OD
Screw #10
Screw 1/4-20
Screw Torx T-25

FUEL LINE KIT

Hose 1/4 OD x 40 ft.
Hose 3/8 OD x 40 ft.
Eyelet fitting 1/4"
Eyelet Fitting 3/8"
Sleeve Fitting 1/4"
Sleeve Fitting 3/8"
Nut Fitting 1/4"
Nut Fitting 3/8"
Connector 1/4"
Connector Fuel Line
Hose 4.00 in. long

FUEL PUMP KIT

Fuel Pump
Hose Fitting 3/8"
Pump Bracket
Harness
Nameplate

BLANK PAGE

Trailer / Container Requirements

Heat King 450 Series Units

 **DANGER:** The front wall of the trailer or container must be structurally strong enough to support the weight of a Heat King 450 series unit!

IMPORTANT: Heat King 450 series units should only be installed onto trailers or containers specifically designed and built for these applications.

UNIT WEIGHTS*		
Heat King 450 series unit with EON battery installed.	HK450 HK450 HO 220 kg (484lbs.)	HK450 MAX 231 kg (510 lbs.)

* Does not include weight of fuel, fuel tank and brackets.

Optional Front Wall Mounted Fuel Tank

 **DANGER:** The front wall of the trailer or container must be structurally strong enough to support the weight of the Heat King 450 series unit, the 65 gallon fuel tank and fuel!

 **DANGER:** An improperly installed fuel tank could lead to serious injury or death! Consult your trailer or container manufacturer for specific details on proper fuel tank installation and recommendations.

IMPORTANT: Heat King 450 series units should only be installed onto trailers or containers specifically designed and built for these applications.

Trailer / Container Requirements

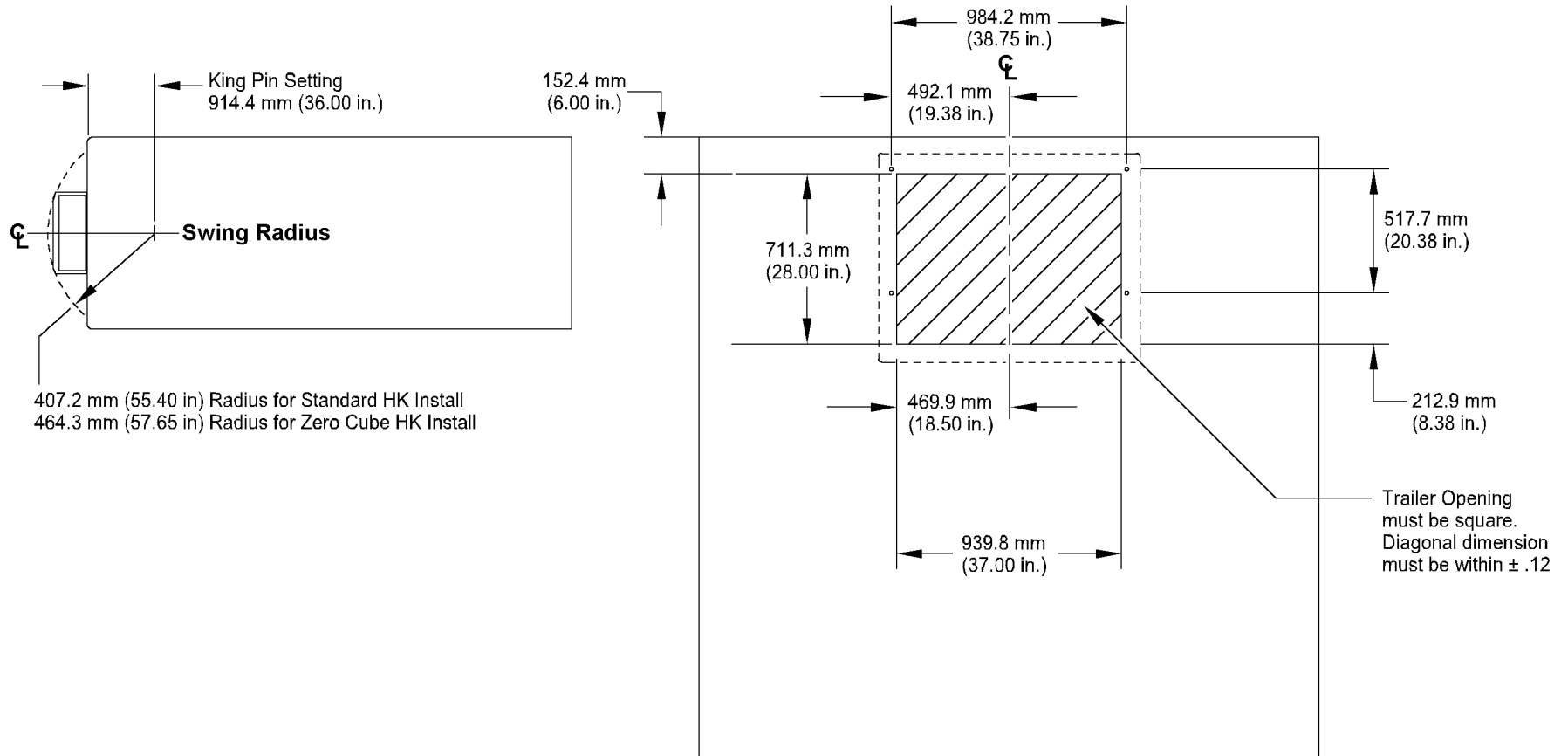

AAA665

Mounting Bolt Specifications and Installation Requirements

Mounting Bolts Specifications

 **DANGER:** The use of mounting bolts other than those specified could result in severe damage to equipment, void the warranty or cause personal injury or death!

NOTE: Mounting hardware to be supplied by installer.

- Use Metric M12 x 1.75 pitch class 8.8 (1/2 in.-13 UNC - 2B Rolled thread grade 5), medium carbon steel bolts and locking nuts.
- All hardware must be zinc plated with dichromate finish.

Mounting Bolt Installation Requirements

 **DANGER:** Four mounting bolts must be installed to properly secure the unit to the trailer front wall! Failure to do so could result in severe damage to equipment, void the warranty or cause personal injury or death!

NOTE: The location of the unit mounting bolts in the trailer front wall is critical to proper unit installation.

- A gasket sealing surface of 76.2 mm (3.00 in.) wide all around the trailer wall opening must be free from rivets or bolt heads and flat within 6.5 mm (.25 in.)
- All mounting bolts must be square with the front wall and securely fastened to the trailer wall in such a manner to allow the mounting nuts be torqued to 82 N•m (60 ft. lbs.) from outside the trailer.
- Mounting bolts are to extend 57.2 mm (2.25 in.) beyond the front wall (**Detail I**).
- Surface of all mounting bolts are to be flat within 2.5 mm (0.10 in.).

Mounting Bolt Specifications and Installation Requirements

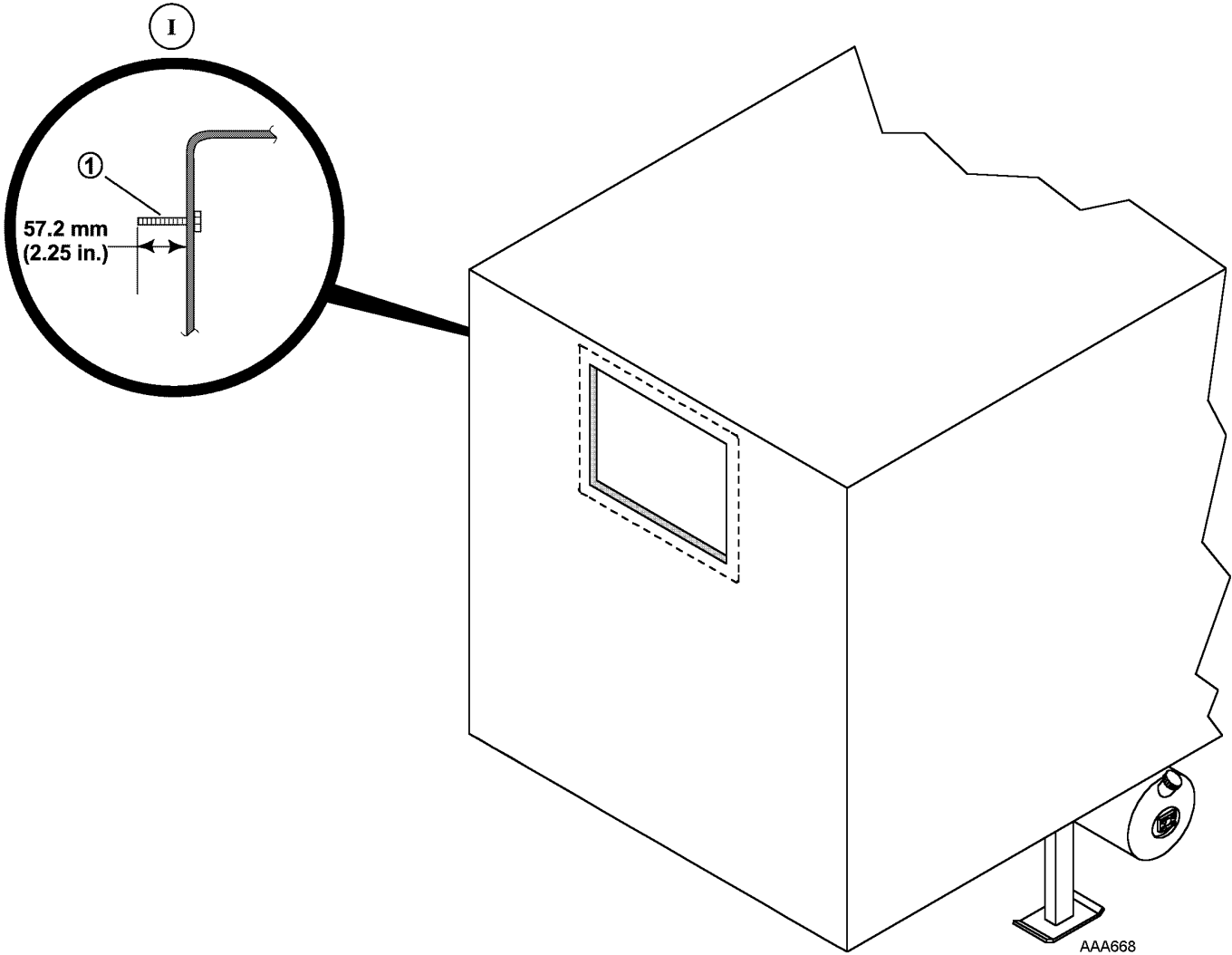

Unit Dimensions

HK450, HK450 HO and HK450 MAX Units

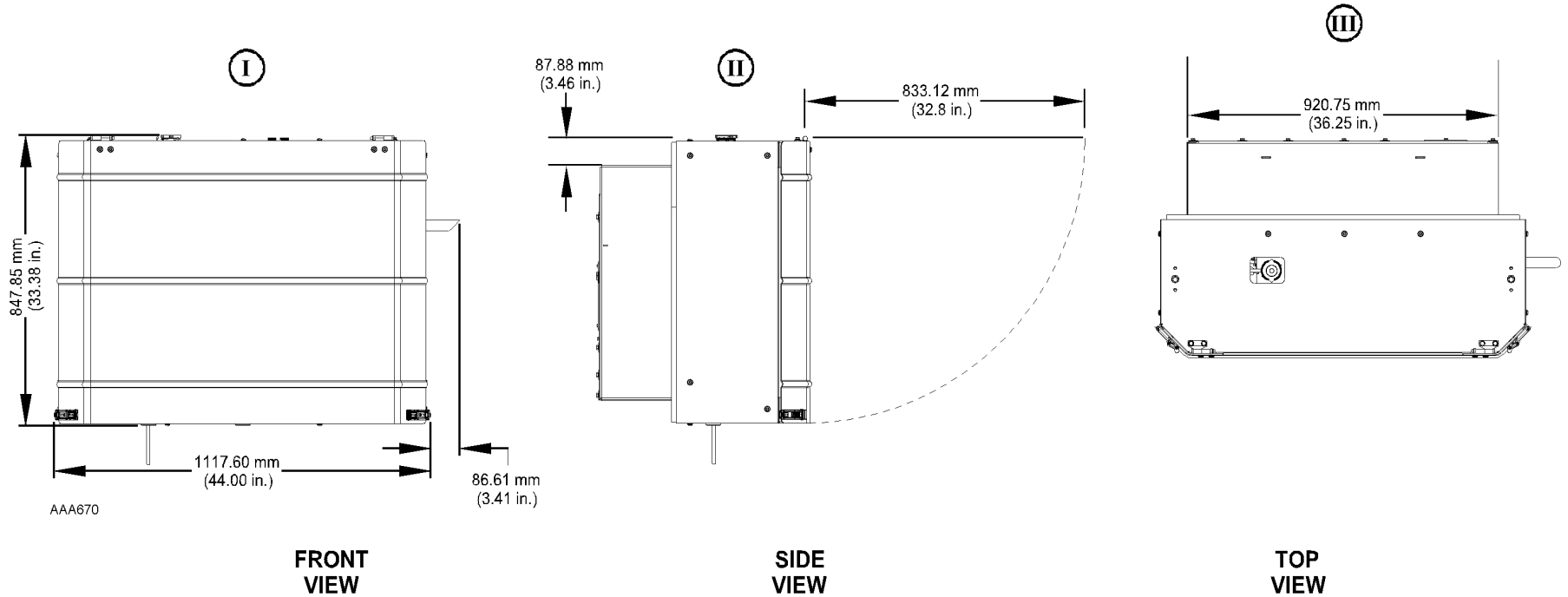

HMI Remote Mount Dimensions

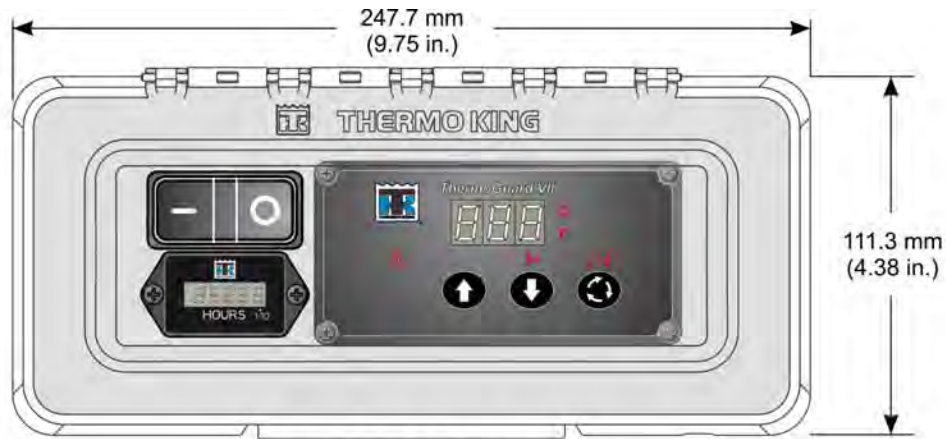

FRONT VIEW

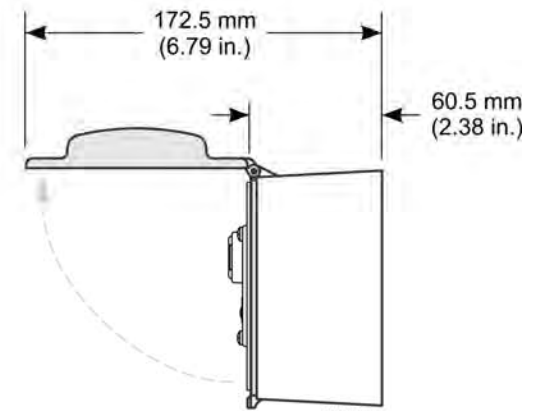

END VIEW

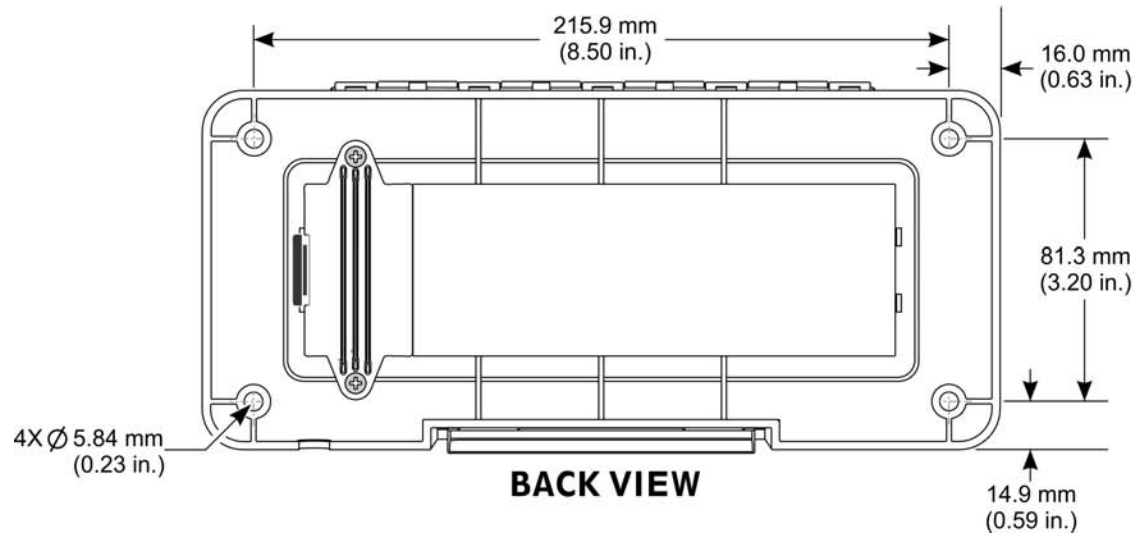

BACK VIEW

Battery Selection Guide

Refer to Service Bulletin T&T 446 for more information regarding Battery Selection and Maintenance.



CAUTION: Do not connect other manufacturer's equipment or accessories to the Thermo King unit! This could result in severe damage to equipment and void the warranty!

IMPORTANT: The specified battery, electrical wiring and electronic controls were designed to operate and maintain only the Thermo King refrigeration system and factory authorized Thermo King options.

Trailer units are designed for one 12 volt, Group 31 battery supplied by the installer.

The battery must be suitable for deep cycling, heavy duty and rated with a minimum of 95 amp/hr.

NOTE: See following table for Thermo King approved batteries. Refer to Service Bulletin T&T 446 for more information regarding Battery Selection and Maintenance.

BATTERY APPLICATION TABLE		
750 CCA Wet Cell Thermo King ReliaMax 750S P/N 203-731 Threaded Stud P/N 203-730 SAE Post	925 CCA Wet Cell Thermo King ReliaMax 925N P/N 203-733 Threaded Stud P/N 203-732 SAE Post	1150 CCA Dry Cell (AGM) Thermo King EON P/N 203-550 Threaded Stud P/N 203-551 SAE Post
<ul style="list-style-type: none"> • Wet Cell Technology • Better suited for warmer climates • Less cranking power at low ambient temperatures • 18-24 month expected life *see note below • Choose for southern climates 	<ul style="list-style-type: none"> • Wet Cell Technology • Better suited for colder climates • High cranking power at low ambient temperatures • 18-24 month expected life *see note below • Choose for northern climates 	<ul style="list-style-type: none"> • Dry Cell (AGM) Technology • Better suited for all applications • High cranking power at lower ambient temperatures • Suited for extreme temperatures • Best for high cycling applications (Cycle-Sentry use) • 5-7 year expected life
<p>* NOTE: Wet cell battery life and maintenance requirements are determined by the operating environment and the charge/discharge rate (cycles) while the battery is in service. Higher ambient temperatures and frequent discharges will shorten a wet cell battery's overall life expectancy and increase maintenance requirements.</p>		

Group 31 Battery Dimensions

Lug Connections

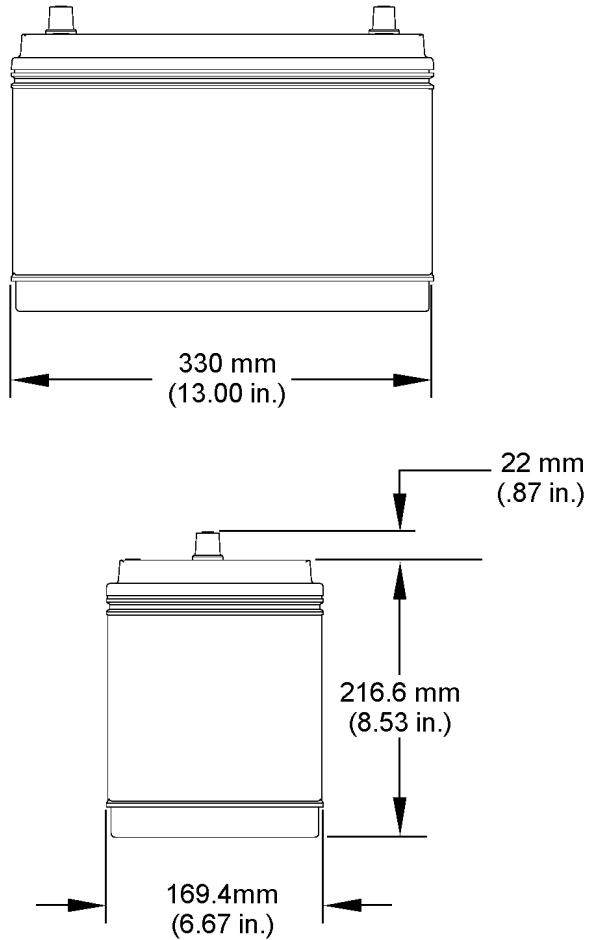

Threaded Stud Connections

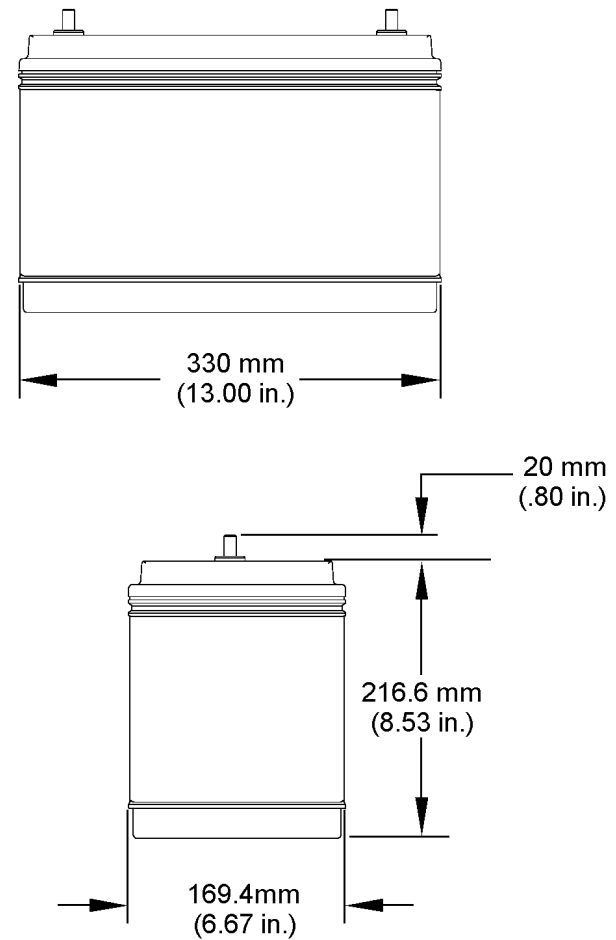

AAA403

Installing the Unit - Standard Installation

Uncratering the Unit

 **DANGER: Do not use a forklift to install the unit! This could result in severe damage to the equipment, void the warranty or cause personal injury or death!**

 **WARNING: Use only locking hooks to safely lift the unit! Failure to use locking hooks could result in severe damage to the equipment, void the warranty or cause personal injury or death! (Detail I).**

To avoid unnecessary damage to your unit, place the crated unit near the trailer prior to its removal. Carefully remove top boards of the crate, the installation kit boxes, and any other loose components from rear of unit.

1. Attach two forged lifting eyebolts (1/2-13 UNC) into the thread holes located on top of unit (**Detail I**).
 - Attach lifting device to eyebolts and slightly raise unit and remove hardware holding unit to crate.

Standard Installation

2. Lift the unit and position it in the trailer opening. With the unit access door open, align the four unit mounting holes with the trailer mounting bolts.
3. Attach supplied 1-1/4" washers and locking nuts. Torque to 82 N•m (60 ft. lbs.).
4. See "Installing the Remote HMI" on page 20.

Exhaust Drain Tube (HK450 MAX Units Only)

5. From **inside** the unit, place the supplied hose clamp over the end of the copper exhaust drain tube and slide it up the tube a few inches.
 - From **under** the unit, insert the drain hose up through the two grommets located in the frame and over the copper exhaust drain tube. Slide the hose clamp down onto the drain hose and tighten clamp securely.
 - Route the drain hose straight down past the bottom of the trailer and secure with supplied clamps and screws. Be sure not to pinch the drain hose closed when routing and installing clamps.

Zero-Cube Option

Zero-Cube installation instructions (TK 56142) are available at Thermo King iService or Thermoking.com.

Exhaust Extension Option

When installing an optional exhaust extension kit 701181 or 701182, follow the instructions that are included with the kit.

Installing the Unit - Standard Installation

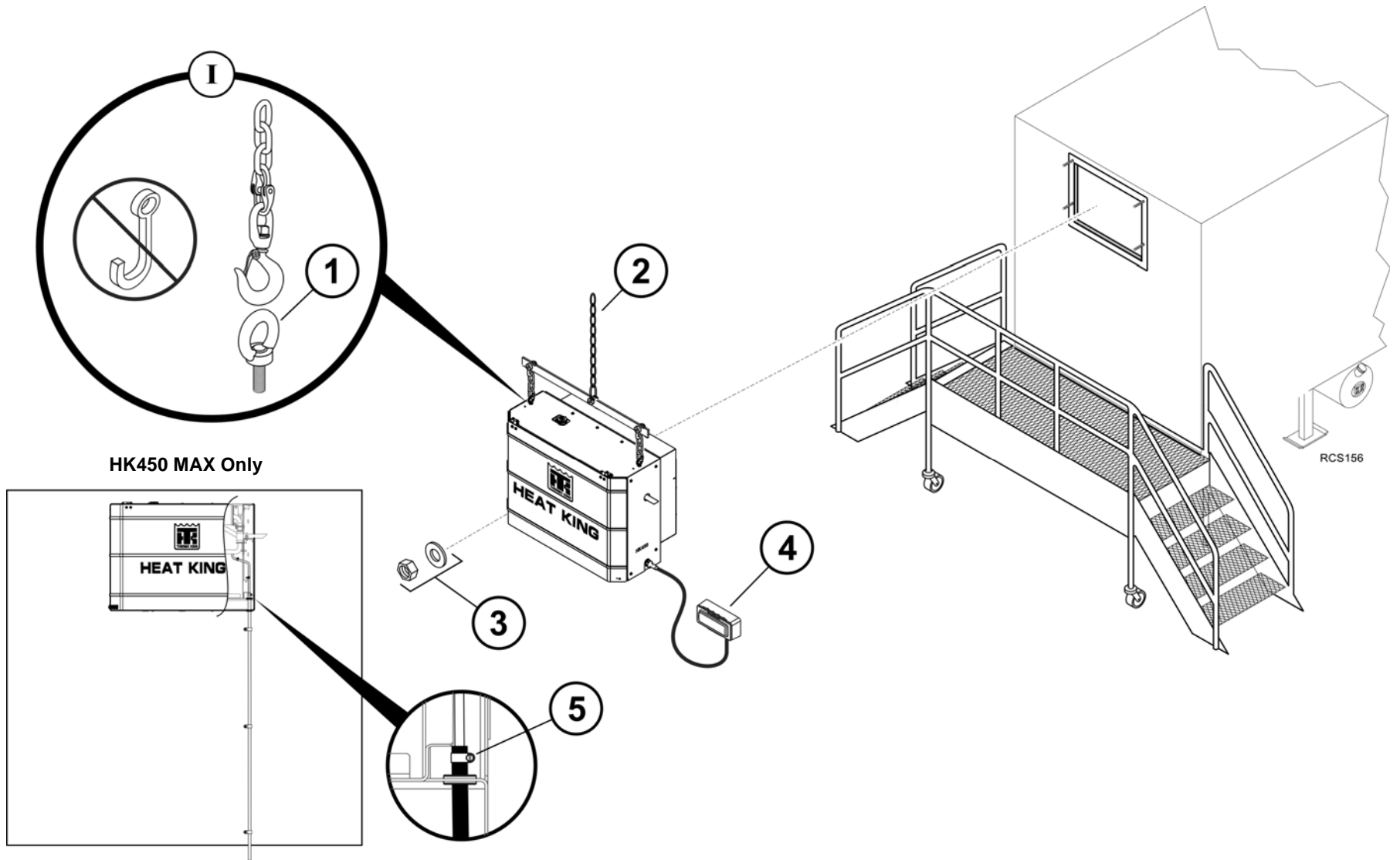

Installing the Remote HMI

NOTE: *The installation views shown are for reference only. The actual locations chosen for installing the remote HMI may vary per your specific application and should not interfere with the operation of the trailer or container.*

Surface Mount Installation

1. Position the HMI onto the surface of the front wall while providing a drip loop as shown.
2. Open the front cover to access the four mounting holes.
 - Secure to the trailer wall with the supplied T-25 Torx head self tapping screws.

IMPORTANT: *Do not overtighten the screws or the plastic enclosure will be damaged.*

3. Secure the harness to the trailer wall with the supplied clamps and self tapping screws.

Flush Mount Installation

NOTE: *Installer to provide a recessed pocket in the trailer wall to accommodate the remote HMI. This recessed pocket must be deep enough to help protect the HMI from damage and allow for water drainage. See “HMI Remote Mount Dimensions” on page 15.*

1. Position the HMI into the recessed pocket while providing a drip loop as shown.
2. Open the front cover to access the four mounting holes.
 - Secure to the recessed pocket with the supplied T-25 Torx head self tapping screws.

IMPORTANT: *Do not overtighten the screws or the plastic enclosure will be damaged.*

3. Secure the harness to the trailer wall with the supplied clamps and self tapping screws.

Installing the Remote HMI

Surface Mount Installation

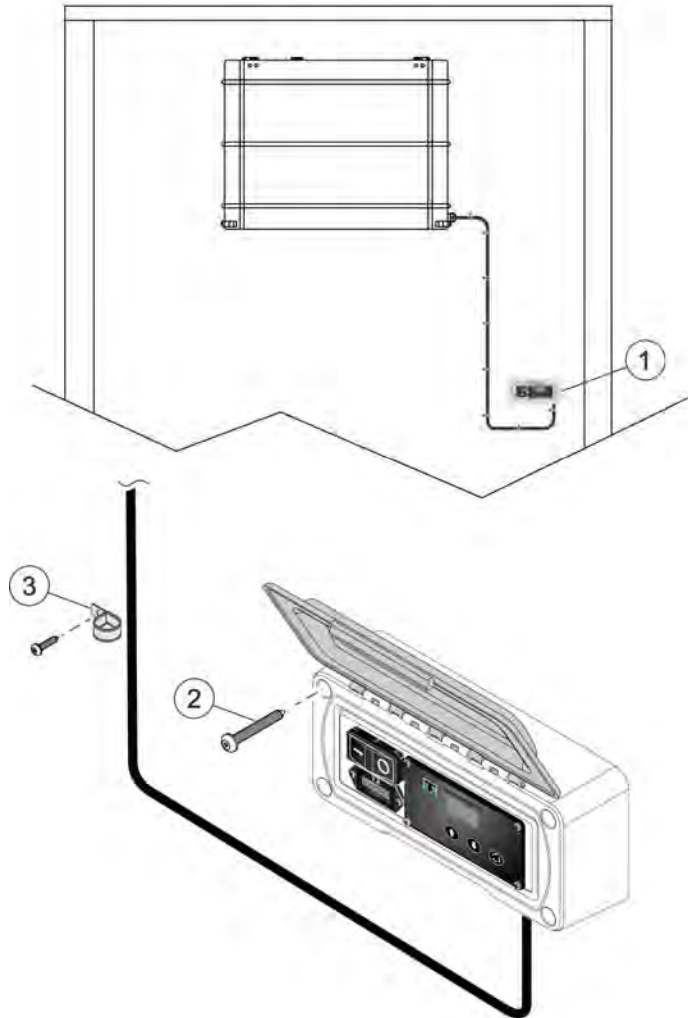

Flush Mount Installation

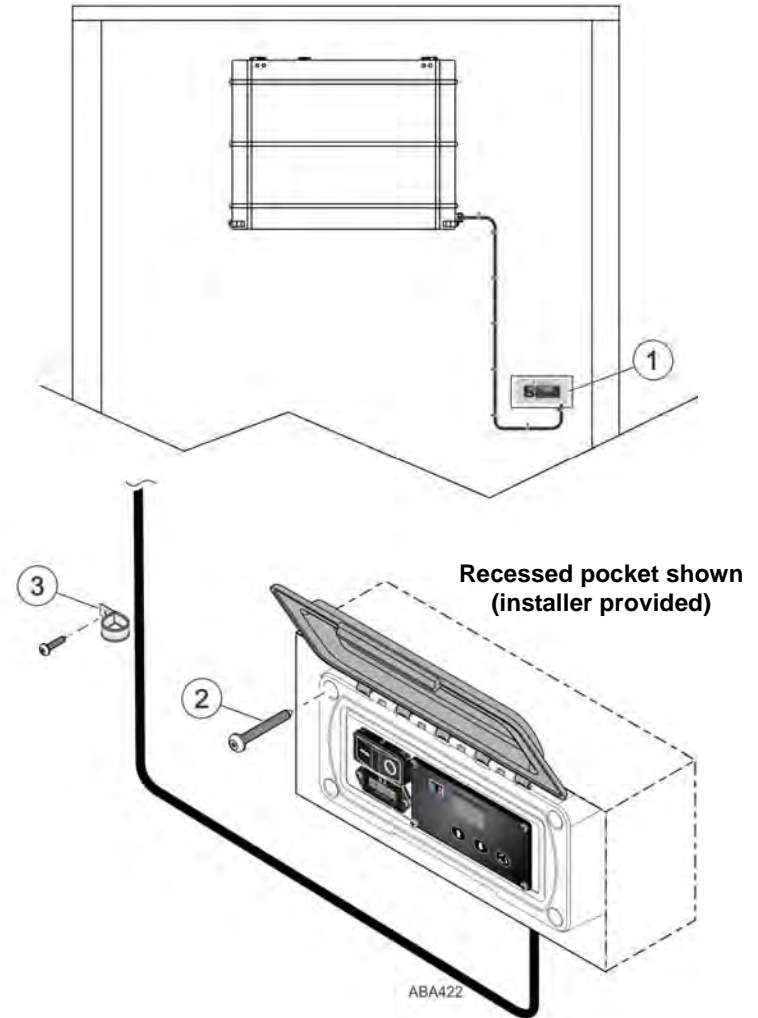

Installing the Fuel Pump and Fuel Lines

FOR OPTIONAL UNDER CHASSIS FUEL TANKS

Installation Recommendations

 **DANGER: Leaking fuel lines could cause a fire resulting in death or serious injury! All fuel line fittings must be tight and leak free!**

 **DANGER: Do not route fuel lines with battery cables or electrical wires, as this could cause a fire!**

- All fuel lines should be routed in a protective housing with no kinks and sharp bends.
- Rubber grommets must be used when routing fuel lines through holes in metal.
- Secure all fuel lines with provided clamps.
- Remove plastic cap from the fuel vent and point the outlet towards the rear of the trailer.

IMPORTANT: *The factory installed fuel tank air vent must be in place and functional for the Thermo King unit's fuel system to operate correctly and for the fuel tank to remain in compliance with Federal Motor Carrier Safety Administration specifications (title 49, paragraph 393.67). A plugged or restricted fuel tank air vent can result in premature damage to the fuel pump and could also cause severe damage to the fuel tank. NEVER remove or install any other component in place of the fuel tank air vent.*

Installing the Fuel Pump and Fuel Lines

1. Install the fuel pump and bracket as low as possible to provide rapid pump priming.
2. Route the **fuel supply** line from the fuel filter located inside the unit, down to the fuel pump and then to the fuel pickup tube on the fuel tank. Install fuel line connectors (provided in installation kit), cut end of fuel line at a 45 degree angle and insert into fuel pickup tube until it is 38.1 mm (1.50 in.) from the bottom of the tank and tighten securely.
3. Route the **fuel return** line from the fuel filter located inside the unit down to the fuel tank return fitting. Attach fuel line connectors and tighten securely.
4. Route the electrical harness from the unit to the fuel pump and attach to the fuel pump connector. ***The connector must be installed out of road spray area.***

NOTE: *Add sufficient amount of fuel (1/4 tank) to allow the unit to run for 8 to 12 hours during engine break-in and pre-delivery procedures.*

Installing the Fuel Pump and Fuel Lines

FOR OPTIONAL UNDER CHASSIS FUEL TANKS

FUEL FILTER LOCATED INSIDE UNIT

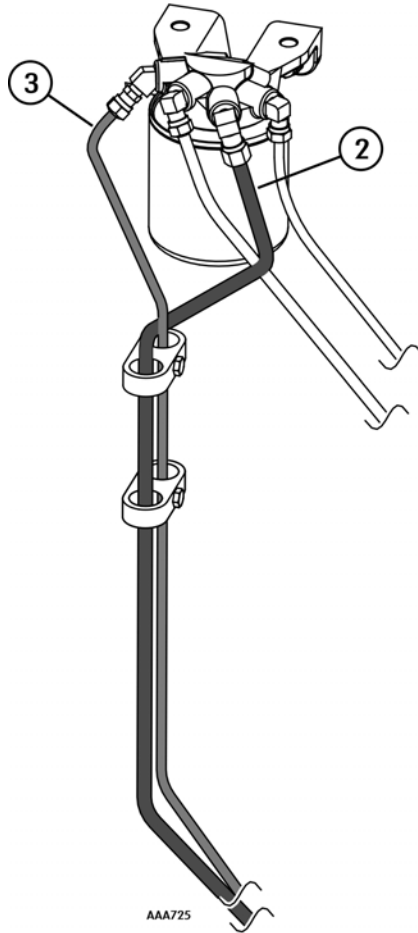

FUEL PUMP LOCATED OUTSIDE TRAILER

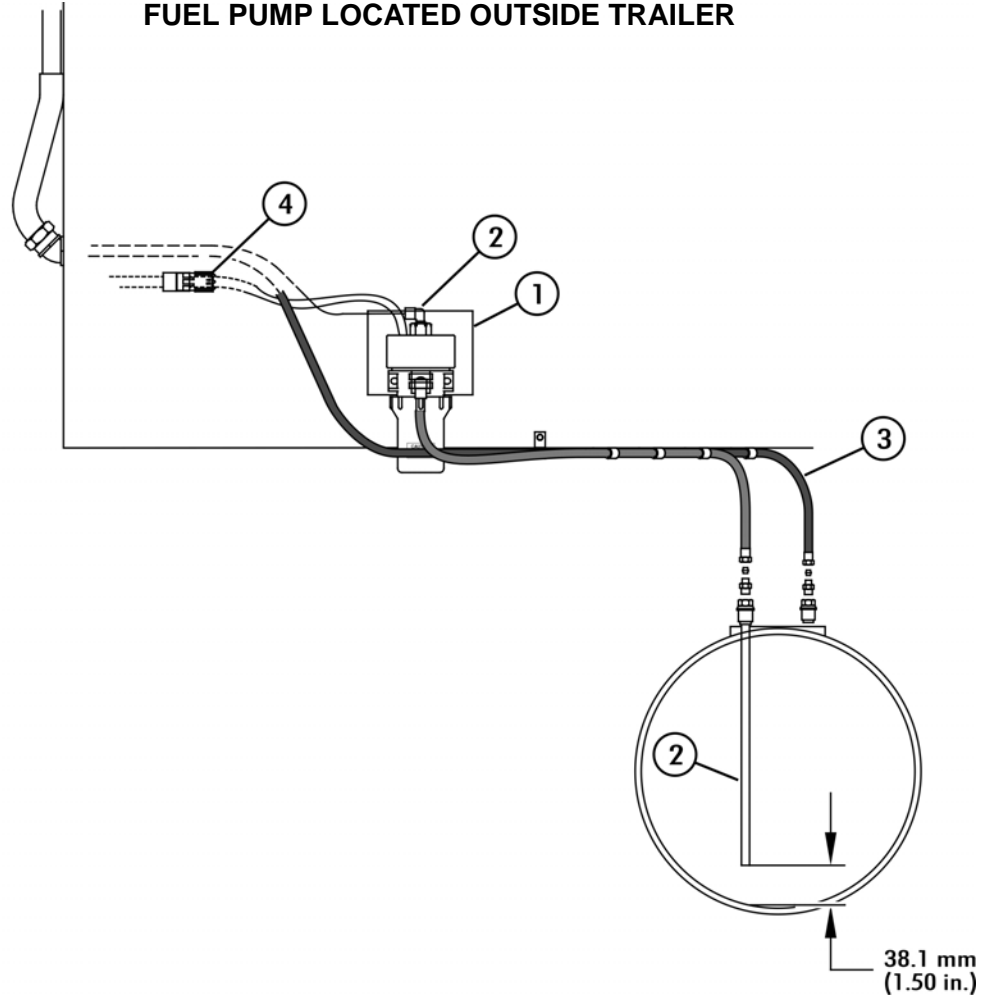

Installing the Fuel Pump and Fuel Lines

FOR OPTIONAL NOSE MOUNTED L-SHAPED and RECTANGLE SHAPED 65 GALLON FUEL TANKS

Fuel Pump Installation

 **DANGER: Leaking fuel lines could cause a fire resulting in death or serious injury! All fuel line fittings must be tight and leak free!**

 **DANGER: Do not route fuel lines with battery cables or electrical wires, as this could cause a fire!**

1. The fuel pump is to be mounted inside the unit directly behind the air cleaner with provided hardware.
 - Remove the two 1/4-20 screws, flat washers and locking nuts that are provided on the frame directly behind the air cleaner.
 - Install the fuel pump using this hardware. Tighten hardware securely.
2. Route and attach the fuel pump harness to the fuel pump.

Fuel Line Installation

3. Remove the protective plugs from each of the fuel fittings and install the fuel line supply and return line fittings securely.
4. **FUEL SUPPLY** - Route fuel lines from:
 - Supply fitting on the fuel filter to the top outlet fitting of the fuel pump.
 - Side inlet fitting on the fuel pump to the fuel tank fitting.
 - Tighten all fuel line fittings securely.
5. **FUEL RETURN** - Route fuel line from:
 - Return line fitting from the fuel filter to the fuel tank fitting.
 - Tighten all fuel line fittings securely.
6. Secure all fuel lines adequately with cable ties or clamps.
7. Remove the plastic cap from the fuel vent and point it towards the rear of the unit.

IMPORTANT: The factory installed fuel tank air vent must be in place and functional for the Thermo King unit's fuel system to operate correctly and for the fuel tank to remain in compliance with Federal Motor Carrier Safety Administration specifications (title 49, paragraph 393.67). A plugged or restricted fuel tank air vent can result in premature damage to the fuel pump and could also cause severe damage to the fuel tank. NEVER remove or install any other component in place of the fuel tank air vent.

NOTE: Add sufficient amount of fuel (1/4 tank) to allow the unit to operate.

8. Operate the unit and check all fuel line fittings for leaks.

Installing the Fuel Pump and Fuel Lines

FOR OPTIONAL NOSE MOUNTED L-SHAPED and RECTANGLE SHAPED 65 GALLON FUEL TANKS

FUEL FILTER LOCATED INSIDE UNIT

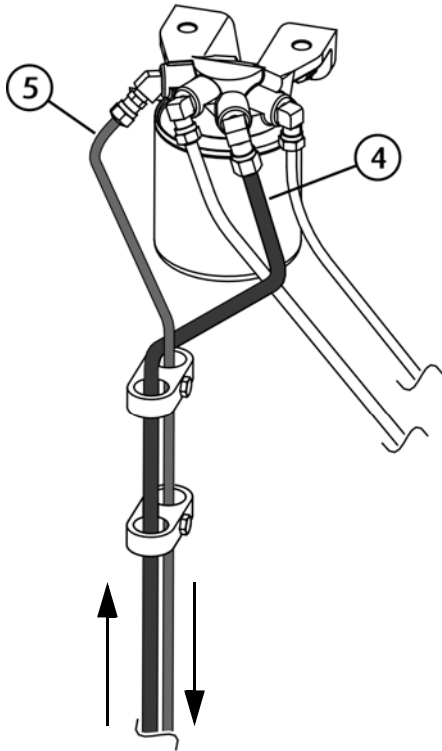

MOUNT FUEL PUMP INSIDE UNIT

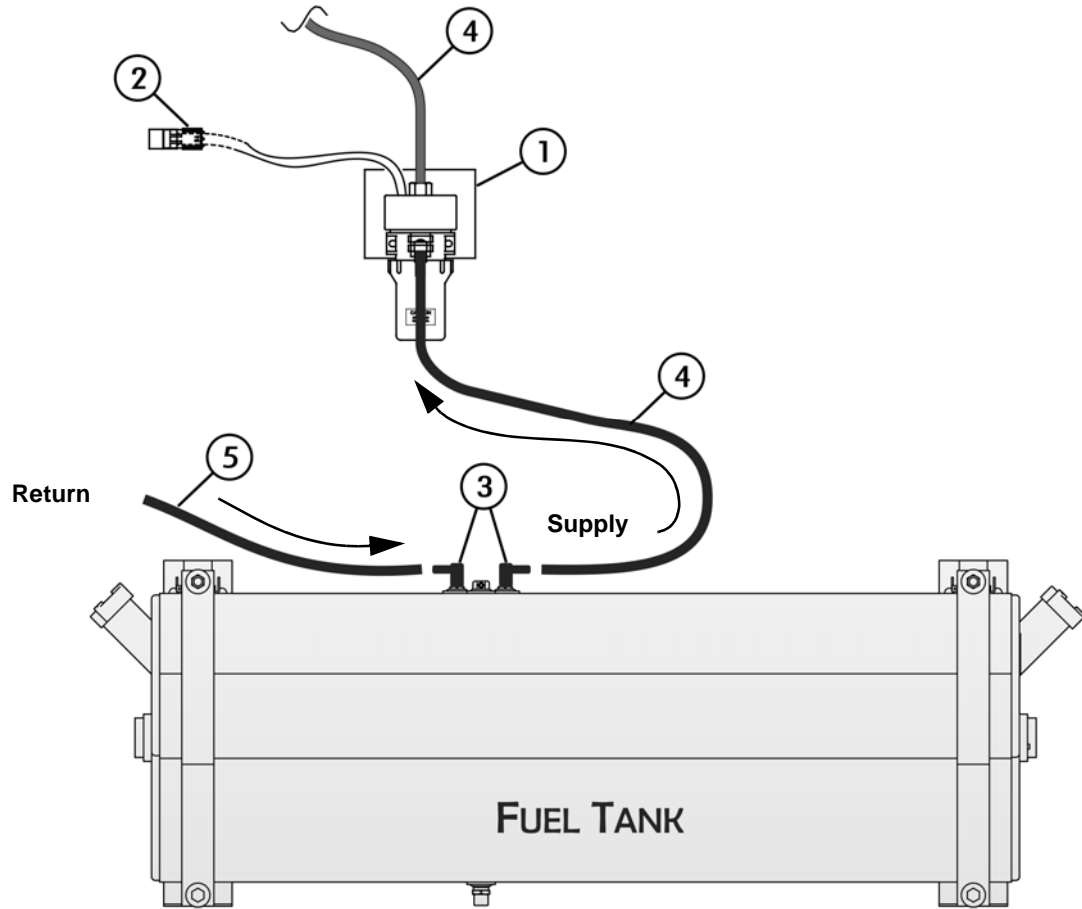

Installing the Battery

Installing the Battery

 **CAUTION: Set all electrical controls to the OFF position before connecting the battery to prevent the unit from starting!**

 **CAUTION: Always wear protective clothing, gloves and eye wear when handling and installing batteries!**

 **CAUTION: Cover battery terminals to prevent accidental shorting during battery installation!**

 **CAUTION: Do not route battery cables together with fuel lines as this could cause a fire!**

 **CAUTION: All battery connections must be clean and tightly secured.**

1. Open unit door to access battery tray.
2. Install battery into tray and secure with hold down bracket, bolts, lock washers and flat washers.
 - Hand tighten both bolts and then torque to 6.8 N•m (60 in-lb). **DO NOT over tighten hardware as this may crack or distort the battery!**
3. Install **positive** + battery cable on the positive battery post **first** to minimize accidental electrical shorting.
4. Install **negative** - battery cable on negative battery post **second** to minimize accidental electrical shorting.
5. Close and secure unit door.

Installing the Battery

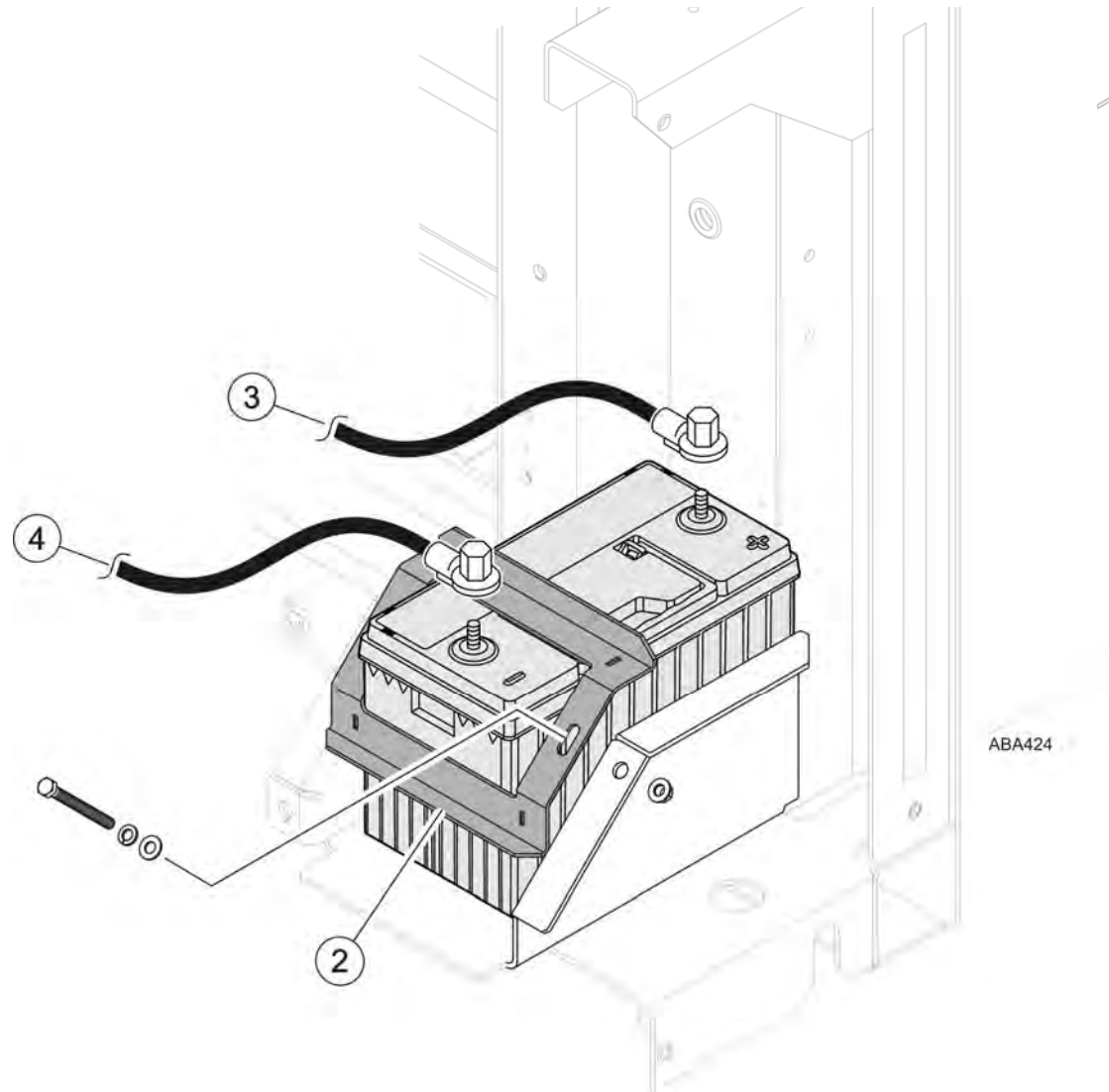

ABA424

Service Test Procedure

Engine Break-in Test

The following procedure is used to run the unit for 10 hours to break-in the diesel engine.

1. Ensure software revision is **EB04** or higher.
2. Open PC Monitor - In the menu on the left is a page called “Service Test” - this page is new, the only test is the break-in Test.
3. Select - Service Test page.
4. Select - Break-in Test by clicking in the dot in front of it.
5. Select - Run Test by clicking in the radio button.
 - A countdown timer for the 10 hour break-in test will appear and start counting down.
 - The PC may be disconnected and the test will continue until the timer runs out.
 - When the test is completed (timer goes to 0) the unit will go back into temp control mode.
 - The test can be stopped prematurely using PC Monitor. The test can be restarted with PC Monitor, and will run for the remaining amount of time.
 - The test can also be stopped by turning the unit off. Turning the unit off will not affect the hours counter. The counter will stop and restart when the operator goes back in to engine break-in test mode.
 - The software only allows the test to be run once. The test cannot be run with a replacement engine.

Service Test Procedure

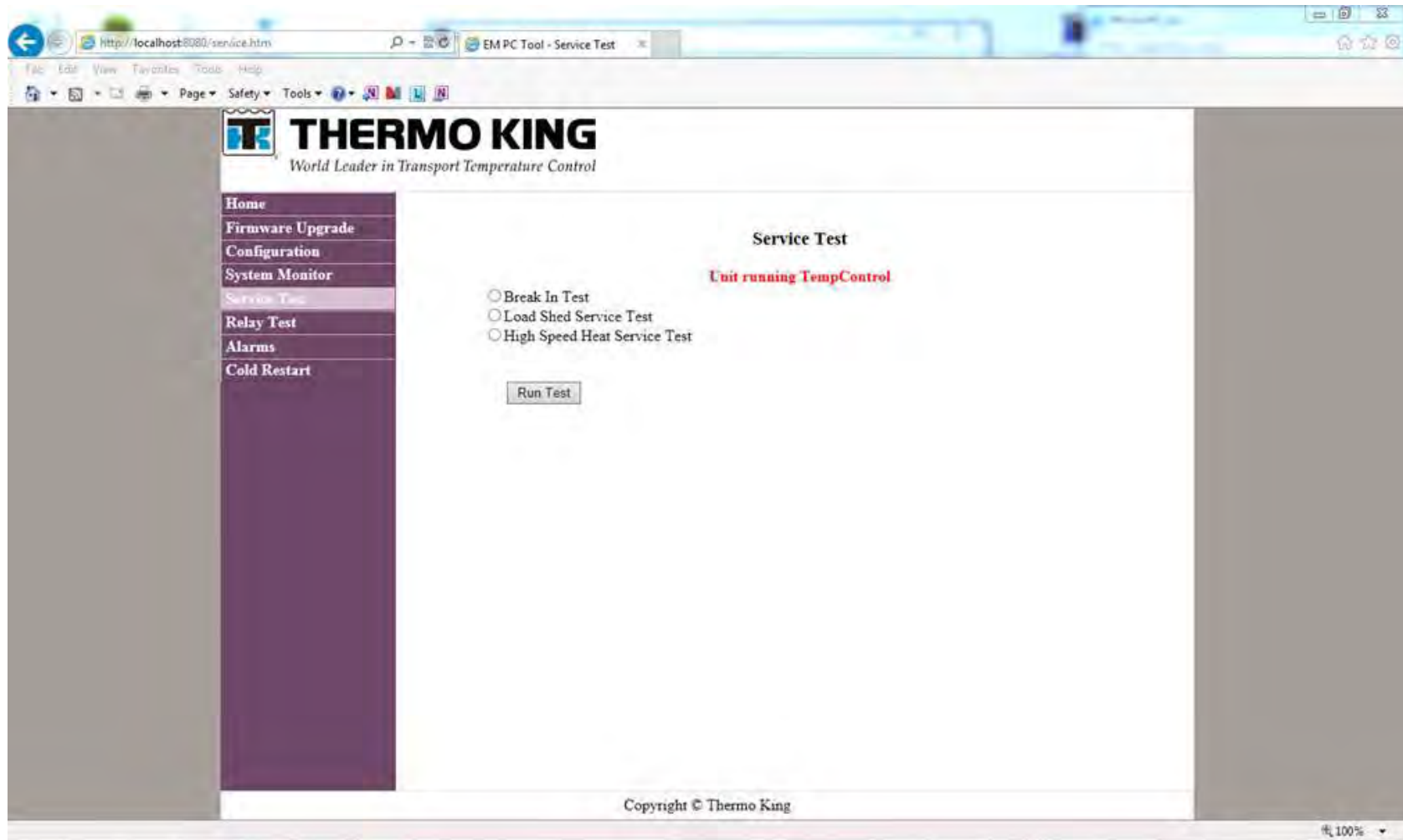

SYSTEM CHECK LIST

- All unit mounting hardware torqued to specifications.
- No air gaps between unit and trailer wall.
- Drain hose properly routed and secured.
- Fuel tank properly installed.
- Fuel lines properly routed and fuel fittings tightened securely.
- Bulkhead properly designed and installed.
- Battery secured correctly and all connections clean and tight.
- Remote HMI mounted securely.
- Run Pre-Trip Inspection (refer to Operator's Manual).
- Run unit under load for eight hours to properly break-in engine.
- Release to customer.



Ingersoll Rand's Climate Solutions sector delivers energy-efficient HVACR solutions for customers globally. Its world class brands include Thermo King, the leader in transport temperature control and Trane, a provider of energy efficient heating, ventilating and air conditioning systems, building and contracting services, parts support and advanced controls for commercial buildings and homes.