



THERMO KING

SG-3000e Series Generator Sets

A low emission, reliable source of electric power for refrigerated containers.



TRANE
TECHNOLOGIES

SG-3000e
THE PROVEN STANDARD
FOR RELIABILITY



For years, Thermo King has been leading the way in making more efficient, reliable units available to all customers.

The SG-3000e genset is the result of years of experience in designing and maintaining units for different climatic and operational conditions. The durable genset benefits from the most advanced technology and a highly reliable design.

The result? A low emission, reliable source of electric power for refrigerated containers, no matter the ambient temperature or cargo type.

ECOPOWER AS STANDARD

Proven fuel saving technology now delivered as standard via a proven, high performance engine and generator.

P. 3

SG-3000e SERIES GENERATOR SETS

Peace of mind - power all reefers, reliably

P. 4

SG+1.5 ADVANCED CONTROLLER

Simple diagnostics and advanced remote monitoring capabilities

P. 5

SG-3000e: PRODUCT RANGE

Multi-configurations and options available including tank-less solutions.

P. 6

SPECIFICATIONS

Including both clip-on and undermount options, the SG-3000e offers solutions for a variety of different applications.

P. 7

SG-3000e NOW WITH ECOPOWER AS STANDARD

The combination of Thermo King's patented technology and cutting-edge hard- and software enhancements lead to the SG-3000e's record fuel savings.

The genset delivers more than 20% fuel savings compared to standard offering while using enhanced operation mode.

Fuel consumption
(gal/h)

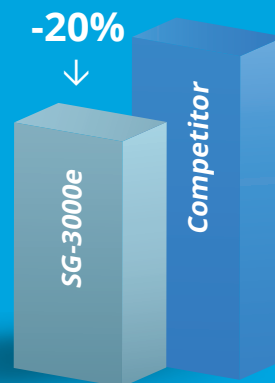

SG-3000e Series Generator Sets

POWERS ALL REEFERS

The SG-3000e Series can power all ISO reefers under any condition thanks to its 30.1 hp engine.

ROBUST & RELIABLE

Designed for tough conditions. The SG-3000e has a robust steel frame, mechanical engine and an even more durable alternator.

FLEXIBILITY

Specifically designed for reefer applications, the SG-3000e is available in 3 models: Clip-On, Center-Mount and Side-Mount.

EASY TO OPERATE

The user-friendly interface features a multi-language, high resolution display that ensures that the unit is operated properly.

CONVENIENT

Extremely low fuel consumption and extended maintenance periods result in lower life-cycle costs.

THE SG-3000e FEATURES & BENEFITS

FEATURES

- Steel frame with extensive 6 step cleaning finished in powder-coated stainless steel and zinc dichromate and e-coated copper tube and aluminum fin radiator
- Next generation SG+1.5 microprocessor controller with user friendly full text menus and advanced diagnostics
- Advanced engine technology featuring an innovative high pressure injection pump
- High efficiency generator featuring robust design, stable voltage control and premium corrosion protection
- Patented cyclonic media air cleaner and Thermo King patented spin-on, self-evacuating fuel filter
- Extended maintenance intervals (EMI 3000) allowing 3,000 hours between services
- Fuel filter (EMI 3000) with extended maintenance interval

BENEFITS

- Provides extended corrosion resistance in harsh environments
- Assures ease of use and service
- The guarantee of a long term investment
- Greater efficiency, reliability and corrosion resistance
- Improved filtering capacity for a longer engine life and extended maintenance intervals
- Reduced maintenance costs, improved uptime and extended engine life

SG+1.5: the Next Generation of Microprocessor Controllers

IMPROVED CONTROLLER

Get a longer trace of operation history with the increased datalogger memory, USB port available for quick log download and software update.

IMPROVED ENGINE MANAGEMENT

Ability to operate genset at variable speeds for reduced fuel consumption and emissions.

USER-FRIENDLY INTERFACE

A 4-lines, clear display allows full-message text for immediate understanding of the unit status, settings and alarm messages. Eliminates the need for acronyms and code tables while maintaining the same efficient menu structure of the previous model.

DUAL LANGUAGE SUPPORT

The extended memory and advanced menu system supports both English and Spanish. This not only applies to the alarms, but to the entire menu navigation process.

ADVANCED DIAGNOSTICS

Simplified pre-trip components test function and advanced self-checking diagnostic capabilities, including manual function tests and assuring trouble-free operation.



FUEL MONITORING CAPABILITY

Full download of fuel data is available by connecting to the download port on the front of the control box. Keeps track of fuel consumption and detects abnormal situations.

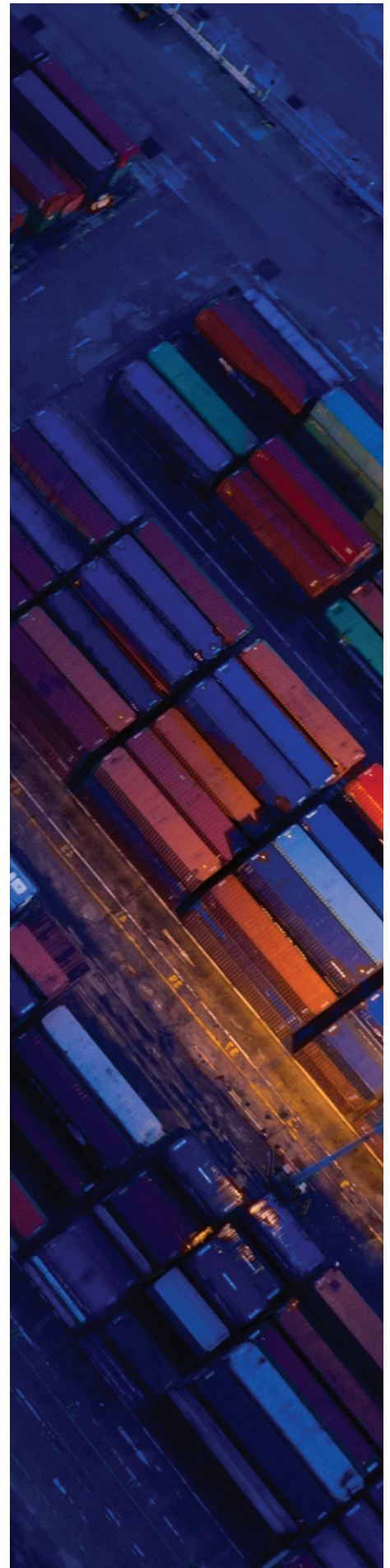

SG-3000e:

Product range

FUEL MONITORING CAPABILITY

Full download of fuel data is available by connecting to the download port on the front of the control box. Keeps track of fuel consumption and detects abnormal situations.

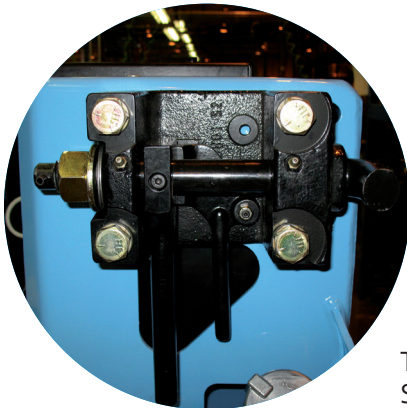
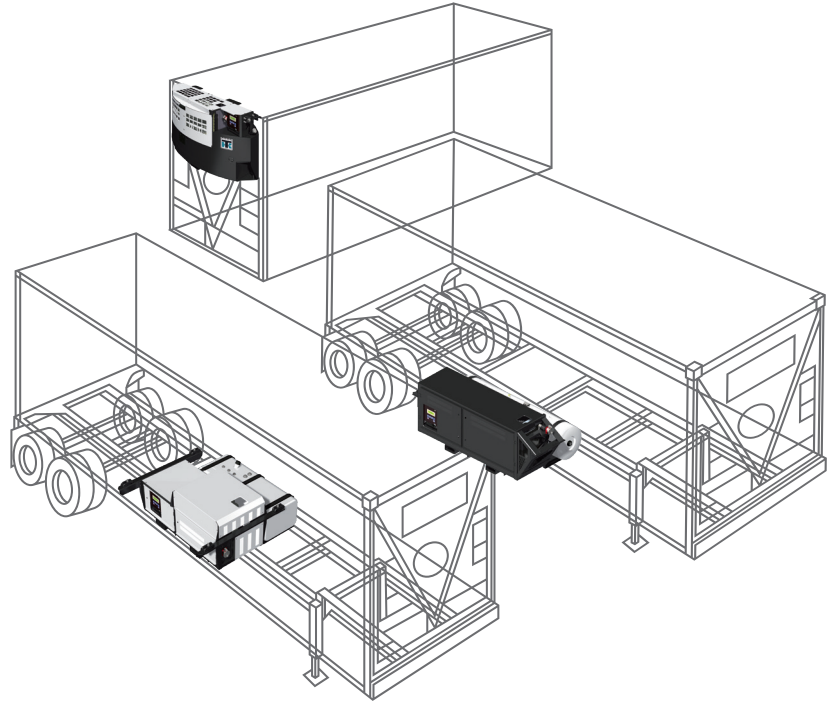

Thermo King patented
SGCO Dual-Clamp Mount

CENTER-MOUNT CONFIGURATION SGCM-3000e

The centermount model mounts under the centre of the container chassis between the I-beams to allow for maximum road clearance and an even weight distribution. Built-in quick disconnect mounting hardware allows it to be easily mounted and removed. It has an integral 80 gallon fuel tank.

SIDE-MOUNT CONFIGURATION SGSM-3000e

This model is designed for applications requiring under mounting on the side of a container chassis rather than in the centre. It includes a 75 gallon fuel tank and optional quick connect/disconnect mounting arms to further simplify application. Tank-less option available.

Specifications

ENGINE	TK Diesel engine 30,1 hp, mechanical direct injection, naturally aspirated with closed crankcase ventilation
FUEL TYPE	No. 2 diesel (under normal conditions) / No. 1 diesel (cold weather fuel)
ROTATIONAL SPEED	1890 ±10rpm / 1560 ±10-0rpm
GENERATOR	460/230Vac, 3Phase, 60Hz
OUTPUT POWER	15kW
APPARENT POWER	18.75 kVA
ROTATIONAL SPEED	1800rpm
ELECTRICAL SYSTEM	SG+1.5 microprocessor controller
BATTERY	12V, 925 CCA at -18°C (0°F)
FUEL TANK	Included in all models
SG CLIP-ON	473l (125gal)
SG CENTRE-MOUNT	302l or 198l (80gal or 50gal)
SG SIDE-MOUNT	283l (75gal)

Specifications are subject to change

SGSM-3000e

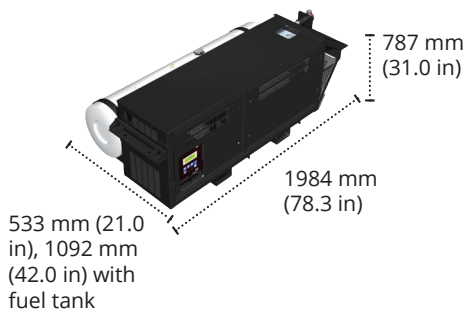

WEIGHT:

678 kg (1495 lbs) – Total Weight, including genset, oil, coolant, dry fuel tank and battery.

SGCO-3000e

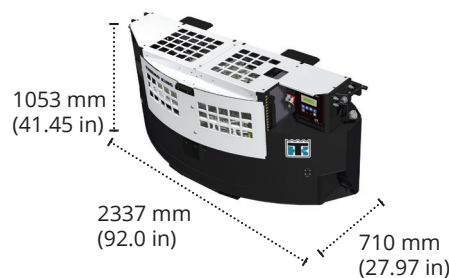

WEIGHT:

818 kg (1804 lbs) – Total Weight, including genset, oil, coolant, dry fuel tank and battery. Genset to be provided with decal indicating gross weight inclusive of fuel.

SGCM-3000e

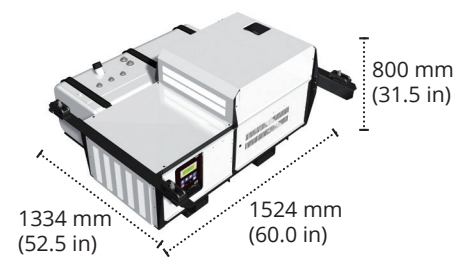

WEIGHT:

671 kg (1480 lbs) – Total Weight, including genset, oil, coolant, dry fuel tank and battery. Genset to be provided with decal indicating gross weight inclusive of fuel.

THE IMPORTANCE OF ALWAYS USING THERMO KING SPARE PARTS

Genuine Thermo King replacement parts are proven time after time to beat the competition in side-by-side testing. Engineered to provide optimal performance and maximum life, Thermo King service parts protect your investment and provide you peace of mind. Insist on Genuine Thermo King parts, every time.



Thermo King – by Trane Technologies (NYSE: TT), a global climate innovator – is a worldwide leader in sustainable transport temperature control solutions. Thermo King has been providing transport temperature control solutions for a variety of applications, including trailers, truck bodies, buses, air, shipboard containers and railway cars since 1938. For more information, visit thermoking.com or tranetechnologies.com.

