



Installation Manual

TriPac® Envidia™ 2

Auxiliary Heating and Cooling Temperature Management System

Rev. A

June 2023

TK 57249-19-IM-EN

TRANE
TECHNOLOGIES

Introduction

This manual was written only to assist with the installation of the **Thermo King TriPac Envidia 2 Auxiliary Heating and Cooling Systems** onto a typical Class 8 semi truck with sleeper. The **Thermo King TriPac Installation Standards Guide** (TK 56498) provides more detailed information that must be followed to safely and properly complete the entire installation.

Before beginning the installation, the installer should confirm with the customer the location for each of the APU's components by using the **APU Installation Questionnaire**. The customer should also be made aware that modifications to existing equipment might be necessary to complete the installation.

Modifications may include:

- Truck's engine must be fitted with an upgraded alternator of 270 amps or more and with upgraded alternator wiring of OEM approved design.
- APU condenser may be directly mounted to the outside of the sleeper.
- APU evaporator, power inverter and/or converter may be installed in existing storage spaces under the bunk or in the toolbox areas.
- APU heating and A/C duct work may be routed with vents installed in existing closets or storage compartments.
- OEM components on the chassis may need to be relocated to accommodate the installation of the APU battery box.
- OEM fuel tank may need to be changed to a smaller size to accommodate the installation of the APU battery box.
- For base level performance - truck battery box must have four 12Vdc batteries connected to provide 12Vdc output.
- For optimum level performance - truck batteries may be upgraded to Thermo King NXT 1150 CCA absorbed glass mat (AGM) batteries.

Due to its complexity, you should not attempt this installation unless you:

- Are an experienced mechanic.
- Can safely lift 34 kilos (75 lbs.)
- Are EPA Section 609 certified and trained in the repair and maintenance of mobile air conditioning systems (in the United States).
- Have a basic understanding of electricity and electrical wiring.
- Have the necessary tools and equipment to complete the installation.
- Follow the safety precautions outlined in the Thermo King TriPac Installation Standards Guide (TK 56498).

This manual is published for informational purposes only. Thermo King makes no representations warranties express or implied, with respect to the information recommendations and descriptions contained herein. Information provided should not be regarded as all-inclusive or covering all contingencies. If further information is required, Thermo King Corporation Service Department should be consulted. Thermo King's warranty shall not apply to any equipment which has been "so installed, maintained, repaired or altered as, in the manufacturer's judgment, to affect its integrity."

Manufacturer shall have no liability to any person or entity for any personal injury, property damage or any other direct, indirect, special, or consequential damages whatsoever, arising out of the use of this manual or any information, recommendations or descriptions contained herein.

Revision History

Revision A (6/23) Released new manual.

Customer Satisfaction Survey

Let your voice be heard!

Your feedback will help improve our manuals. The survey is accessible through any internet-connected device with a web browser.

Scan the Quick Response (QR) code or click [Technical Publications TK Americas Feedback](#) to complete the survey.



Table of Contents

Tips For a Successful Installation	7
Before Beginning the Installation Recommendations	7
Truck’s Alternator Requirements	7
Truck’s Battery Recommendations	7
APU Battery Requirements	7
Battery Box Installation Requirements	9
A/C Condenser Installation Requirements	9
A/C Evaporator / Control Box Installation Requirements	9
A/C Hose Connections and Routing Requirements	10
Electrical Wiring and HMI Controller Installation Requirements	11
D2 / D4 Heater Installation Requirements (Units with Heat Option)	11
Auxiliary Power Accessories Requirements	12
Required Tools and Additional Supplies	13
TriPac Envidia and Envidia 2 Component Dimensions	15
Battery Box Dimensions	15
Condenser Dimensions	17
Evaporator/Control Box Dimensions	18
HMI Controller Dimensions	19
Standard Heater Dimensions	20
High Output Heater Dimensions	21
AC/DC Shore Power Converter Dimensions	22
1000 Watt Power Inverter Dimensions	23
Typical Component Locations	24
Battery Box Installation	26
Standard Installation Method – Mounting Claws	26
Optional Installation Method – Direct Mount	28
Receiver Drier Installation	30
A/C Condenser Installation	32
A/C Evaporator / Control Box Installation	33
A/C Hose Installation	36
A/C System Evacuation and Leak Check Procedures	37
D2/D4 Heater Installation (Heat Option)	38
Heater Location	38
Heater Subassembly and Installation	39

Exhaust and Combustion Air Intake Installation	40
Return and Discharge Ducts and Vents Installation.....	41
A/C Duct Installation	42
Discharge Air Outlet Options.....	42
Discharge Air Duct Installation	43
Discharge Air Vent Installation	43
Backflow Damper Installation	45
Battery Box Harness Installation	46
Condenser Fan and Sensor Harness Installation	50
Ignition Switch and Harness Installation.....	51
HMI Installation	52
USB Service Communication Cable Installation.....	53
D2/D4 Heater Harness Installation (Heat Option)	54
Heater Fuel Pickup Tube Installation (Heat Option)	55
Direct Tank Installation – with OEM Fuel Tank Fittings.....	55
Alternative Installation – Drilling Hole in Fuel Tank.....	57
Fuel Pump and Fuel Line Installation (Heat Option)	59
Tank Mounted Fuel Pump	59
Remote Mounted Fuel Pump with L-Bracket.....	60
Heater Fuel Pump Connections (Heat Option)	61
Auxiliary AC Power Accessories (Option).....	62
DC/AC Power Inverter Only	62
AC/DC Shore Power Converter Only	63
Dual System – DC/AC Power Inverter and AC/DC Shore Power Converter	64
Battery Cable Installation	65
Priming the Heater Fuel Pump (Heat Option)	67
Heater Start-Up Procedures (Heat Option)	68
Diagnostic Tool Overview	68
Perform the Start-Up Procedure.....	68
Heater Start-Up	70
Clearing Faults	70
Quit Start-Up	71
Unable to Perform the Diagnosis	71



A/C System Charging Procedures	72
Operation Checkout Procedures.....	73
Step 1 – Basic Operation Checkout Procedures	73
Step 2 - Detailed Operation Checkout Procedures.....	74
Unit Setup Procedures	74
Envidia 2 HVAC Function Check Procedures.....	75
Air Conditioning Test	75
Heat System Check.....	75
Fan Only Check	75
Alarms.....	76
Envidia 2 Battery Check Procedures.....	76
Battery Condition	76
Battery Discharge	76
Battery Charge.....	76
Exiting Envidia Service Tool	77

Tips For a Successful Installation

Before Beginning the Installation Recommendations

Important: Proper installation of each component onto the vehicle is critical! Refer to the Thermo King TriPac Installation Standards Guide (TK 56498) before beginning the installation. Adhering to the installation standards will help assure the components are installed correctly and the system operates as designed. It is the responsibility of the installer to follow these standards.

- Review component location diagram and discuss with the customer where each component will be installed on the truck.
- Verify tools and special equipment required for the installation are available and in good working condition.
- Open all installation kits and inspect the contents before beginning installation.
- It is recommended that one person performs the installation of all the components **outside** the sleeper while a second person installs all the components **inside** the sleeper. This will help minimize any damage to the sleeper's interior from grease, dirt, etc.

Truck's Alternator Requirements

- The truck's engine must be fitted with an upgraded alternator of 270 amps or more and with upgraded alternator wiring of OEM approved design.

Truck's Battery Recommendations

- It is important not to allow the truck's batteries to become discharged during the APU installation process. A battery charger should be connected to the batteries while the installation is in process or shut the truck's battery power supply completely off using the OEM main battery disconnect switch if available.
- An alternative method is to shut the truck's battery power completely off using the OEM main battery disconnect switch if available.
- For TriPac Envidia 2 **base level performance:**The truck's battery box must have four 12Vdc batteries connected in parallel to provide 12Vdc output.
- For TriPac Envidia 2 **optimum level performance:**Thermo King recommends the truck's batteries be upgraded to Thermo King NXT 1150 CCA absorbed glass mat (AGM) batteries.

APU Battery Requirements

TriPac Envidia 2 units are shipped with Thermo King NXT AGM batteries fully charged and ready to use. Batteries that are kept in stock should not require charging for 2 years if kept below 77 F (25 C). Batteries should be charged when the open circuit voltage (OCV) falls below 12.50 volts.

To charge the NXT AGM battery, use the following guidelines:

1. Verify the output voltage of your battery charger is capable of maintaining 14.1 to 14.7 charging voltage. The recommended charging voltage range for the NXT AGM battery is 14.1 to 14.7 volts. Voltages are to be measured at the battery terminals with the battery connected to the charger.

Important: Never exceed 15 volts when charging the NXT AGM battery. Exceeding 15 volts will cause pressure relief valves to open and out-gas hydrogen and oxygen from inside the battery. This will shorten the life of the battery and could lead to premature battery failure.

2. Battery chargers with the battery type output setting should be set to AGM type battery. **DO NOT** set the output type to gel cell or maintenance free settings.
3. Determine if your battery charger is an automatic or manual charger. Manual battery chargers must be closely monitored during the charge period and for this reason an automatic battery charger is preferred over a manual charger.
 - a. Automatic battery chargers either charge up to a preset voltage and shut off, or charge to a present voltage and then switch to a trickle charge mode. Either one of these battery chargers is acceptable: however, the automatic charger that shuts off may not fully charge the battery.
 - b. Manual battery chargers will have manual controls for setting the charge amperage rate. The charge amperage rate will remain the same until the battery charger is manually shut off.



Tips For a Successful Installation

Important: When using a manual battery charger, set the charger to charge at 10 or 20 amps and limit the charging time based on the batteries state of charge (SOC). Use the chart below as a general guide to determine the amount of time necessary to charge the battery. **DO NOT overcharge the batteries!** See warning below.

Determining Maximum Charge Time Using a Manual Charger			
Voltmeter Reading	State of Charge	Time @ 10 Amps	Time @ 20 Amps
12.84 Volts	100%	0 Hours	0 Hours
12.50 Volts	75%	2 Hours	1 Hour
12.20 Volts	50%	4 Hours	2 Hours
11.88 Volts	25%	6 Hours	3 Hours

⚠ WARNING

Risk of Injury!

Overcharging a battery can cause damage to the battery and possibly cause a fire or explosion. Follow the battery charger's recommendations for monitoring batteries while charging. Batteries should be monitored while charging for signs of internal problems. Signs of internal problems include bulging cases, extreme gassing, pungent smell, and extreme heat. If you notice any of these signs turn the charger off and allow the battery to stabilize before handling or testing.

Cleaning a Battery

Use a damp cloth to clean the top of the battery to eliminate conductive paths created by dirt and dried or wet electrolyte, and to prevent corrosion. Use a battery terminal-cleaning tool that has nonconducting (plastic or rubber) cover to clean the battery terminals when corrosion is present. Replace any battery cables (or cable terminals) that are frayed, corroded, swelled, or damaged to the extent that they cannot be cleaned.

Battery Hold Down Hardware

Batteries are subjected to extreme shock loads and vibration. It is very important to make sure each battery is secured by the proper mounting hardware. Failure to secure each battery correctly can result in premature battery failure. Using a torque wrench, torque the hold down nuts in two step increments:

- STEP 1 - Torque each hold down nut to 60 in-lbs. (6.8 Nm)
- STEP 2 - Torque each hold down nut to 120 to 144 in-lbs. (13.5 to 16.3 Nm)

Battery Cable Mounting

- On threaded stud type batteries, use only stainless steel nuts to fasten the cable to the battery. Torque the nut to 150 to 200 in-lbs. (17 to 22.5 Nm).
- On SAE post type batteries, use only stainless steel battery clamp bolts. Torque the nut to 60 in-lbs. (7 Nm).

Battery Box Installation Requirements

Important: See “Battery Box Installation Standards” in Section 6 of the Thermo King TriPac Installation Standards Guide (TK 56498). **THESE STANDARDS MUST BE FOLLOWED!**

- The battery box is designed to be mounted **only** to the existing truck frame rails. **NO OTHER MOUNTING LOCATION IS ACCEPTABLE!**
- Safely relocate components on the chassis that interfere with the installation of the battery box.
- Check clearance around battery box before beginning the installation.
- Lifting eyebolts (installer supplied) must be forged steel, 1/2"(12mm) diameter.
- Use only forged clevises and pins to attach to the lifting eyebolts.
- The use of a motorcycle/ATV lift or modified floor jack to raise battery box into position is recommended.
- Only the supplied spacer blocks and mounting claws must be used to install the battery box to the chassis frame rail.
- If different mounting bolts are used, they must be Grade 5 and of the correct length. **DO NOT** cut off excessive length bolts and **DO NOT** oil the bolt threads!
- Verify the upper and lower battery box mounting bolts are square and flat with the chassis frame rail before tightening.
- The mounting hardware securing the battery box to the truck’s frame must be correctly positioned and torqued using the four-step tightening sequence described in this manual.

A/C Condenser Installation Requirements

Important: See “Condenser Installation Standards” in Section 6 of the Thermo King TriPac Installation and Standards Guide (TK 56498). **THESE STANDARDS MUST BE FOLLOWED!**

- Keep all A/C fittings capped and sealed until installation of the refrigeration hoses. Refrigerant oil is extremely hygroscopic and a system left open for more than 5 minutes may require extensive evacuation/dehydration time to remove moisture.
- Verify all measurements before drilling any mounting holes.
- Verify there is no interference with any OEM electrical wiring, internal supports, etc. before drilling mounting holes.
- Confirm the condenser location does not interfere with the service or operation of existing tractor components.
- Provide protection to the tractor’s interior and or exterior finish to prevent damage during the installation process.
- Use the stainless steel mounting hardware (supplied in the kit) to mount the condenser.
- Use the large fender washers (supplied in kit) inside the sleeper to provide additional support.
- All mounting holes must be sealed with silicone caulking to prevent moisture or exhaust fumes from entering the sleeper.

A/C Evaporator / Control Box Installation Requirements

Important: See “Evaporator / Control Box Installation Standards” in Section 6 of the Thermo King TriPac Installation and Standards Guide (TK 56498). **THESE STANDARDS MUST BE FOLLOWED!**

- This installation requires a two-person or mechanically assisted lift.
- Keep all A/C fittings capped and sealed until installation of the refrigeration hoses. Refrigerant oil is extremely hygroscopic and a system left open for more than 5 minutes may require extensive evacuation/dehydration time to remove moisture.
- Determine the best location for the A/C Evaporator/Control Box inside the sleeper, typically under the bunk and flush to the front bulkhead.
- Allow adequate clearance for attaching the two air outlet tubes.
- Verify there is no interference with any OEM electrical wiring, internal floor supports, etc. before drilling any mounting holes in the truck.
- The Evaporator/Control Box should be mounted directly onto the floor mat inside the sleeper. Use the supplied template to properly locate the drain and mounting holes.



Tips For a Successful Installation

- Always install the drain valves (kazoos) into drain holes located on the bottom pan of the evaporator.
- The A/C vents should be located and installed to provide maximum air circulation in the sleeper such as: MEDIUM (above lower bunk level) and HIGH (above upper bunk level). NOTE: Locating a vent LOW (floor level) is not recommended. It will significantly reduce driver comfort and reduce maximum system run time.
- All mounting holes must be sealed with silicone caulk to prevent moisture or exhaust fumes from entering the sleeper.
- All edges of access holes made in fiberglass and wood composite floors must be sealed correctly with (installer supplied) fiberglass cloth and resin.

A/C Hose Connections and Routing Requirements

Important: See "Refrigerant Hose and Fittings Standards" in Section 8 of the Thermo King TriPac Installation and Standards Guide (TK 56498). **THESE STANDARDS MUST BE FOLLOWED!**

- Keep all the A/C fittings capped and sealed until the installation of the refrigeration hoses. Refrigerant oil is extremely hygroscopic and a system left open for more than 5 minutes may require extensive evacuation/dehydration time to remove moisture.
- Only cut refrigerant hoses with the correct hose cutting tool (204-677). NEVER USE A SAW!
- Always use the correct hose fitting tool (204-1045) when assembling refrigeration hoses.
- Always lubricate hose fittings with Alkyl Benzene Refrigerant Oil (670404TKA) when assembling to refrigeration hoses.
- Always install and lubricate O-rings with Alkyl Benzene Refrigerant Oil (670404TKA) when connecting refrigeration hose fittings to component connection fittings.
- Refrigeration hoses should be installed onto components in such a way as to allow for vibration and movement of the cab. **THEY SHOULD NEVER BE STRETCHED TIGHT!**
- All refrigeration connections should be tightened securely using two wrenches.
- Always keep refrigeration hoses from rubbing or chafing against sharp metal objects, rotating components or hot components.
- Protective covers or sleeves (installer supplied) for the refrigeration hoses may be required depending on the installation.
- Always install the condenser's receiver drier so refrigerant flow is in the direction indicated by the arrow.
- Thermo King Evacuation Station (204-725) and Evacuation Station Operation and Field Application Instructions (TK-40612) are recommended.
- The oil in the evacuation station vacuum pump should be changed after each use.
- The A/C system must be leak free. Check for leaks by using an electronic leak detector.
- The A/C system will be charged with 2.0 lbs. of R134a refrigerant. **NOTE: Accuracy is important. Over or under charge by 3 ounces will reduce cooling capacity.**

Electrical Wiring and HMI Controller Installation Requirements

Important: See “Electrical Standards” in Section 10 of the Thermo King TriPac Installation and Standards Guide (TK 56498). THESE STANDARDS MUST BE FOLLOWED!

- Electrical wiring should be installed and routed in such a way as to allow for vibration and movement of the cab. THEY SHOULD NEVER BE STRETCHED TIGHT!
- Always keep electrical wiring from rubbing or chafing against sharp metal objects, rotating components or hot objects.
- All electrical wiring should be neatly routed and secured with band wraps or clamps.
- Do not route or bundle 110Vac wires together with 12Vdc wires.
- Do not route electrical wires, harness or battery cables together with fuel lines.
- Excess length of battery cables should be cut off to reduce voltage drop.
- Superlube (203-524) or equivalent should be applied to all electrical connections.
- All main power and ground accessory connections must be installed directly on top of the truck’s battery terminal posts and tightened securely. DO NOT INSTALL UNDER OEM BATTERY CABLES!

D2 / D4 Heater Installation Requirements (Units with Heat Option)

Important: See “Heater Installation Standards” in Section 7 of the Thermo King TriPac Installation and Standards Guide (TK 56498). THESE STANDARDS MUST BE FOLLOWED!

- Determine the best location of the heater inside the sleeper, typically under the bunk. Allow clearance for dismantling for service.
- Install heater so it will maintain a minimum distance of 2.00 inches (50.8 mm) from any heat sensitive or flammable material.
- The heater must only be mounted on a flat horizontal surface.
- Heater must be installed flush with the floor pan (i.e. sheet metal, fiberglass, etc.) to ensure proper sealing of the mounting plate and gasket.
- All edges of access holes made in fiberglass and wood composite floors must be sealed correctly with (installer supplied) fiberglass cloth and resin.
- Outside air intake and exhaust hoses must be installed correctly for the heater to operate safely.
- Exhaust hose should be mounted slightly downwards to help drain off condensation.
- Install exhaust hose so it will maintain a minimum distance of 2.00 inches (50.8 mm) from any heat sensitive or flammable material.
- Inside air inlet and outlet ducts must be installed correctly for the heater to operate safely.
- Pulse type fuel pump outlet must be installed at a 15 to 35 degree angle up from horizontal to operate correctly.
- Fuel pickup tube must be installed correctly in the fuel tank or the heater will not operate.
- Fuel line from the pickup tube to the fuel pump to the heater should be routed at a continuous rise. Use a hose cutter or sharp knife to cut plastic fuel lines. Do not use a wire cutter as this will pinch the plastic fuel line closed.
- Do not route electrical wires, harness or battery cables together with fuel lines.
- BEFORE operating the heater, the fuel lines must be bled of air using the Heater Priming Harness (204-1144) or damage to the fuel pump will result.
- The Diagnostic Code Reader (204-1143) must be used to setup and operate the heater in the run-in mode.



THERMO KING

Tips For a Successful Installation

Auxiliary Power Accessories Requirements

Envidia 2 installations may also include optional auxiliary power accessories such as:

- DC/AC Power Inverter
- AC/DC Shore Power Converter
- Solar Panel(s)

When installing any of these power accessories, they must be connected **ONLY** to the tractor's batteries per the installation instructions.

Important: DO NOT connect auxiliary power accessories to the TriPac Envidia 2 batteries.

Required Tools and Additional Supplies

Note: While basic mechanics tools and refrigerant service equipment are a necessity, there are also special tools that are required when installing Thermo King TriPac Units. For a complete listing of special tools, See "Special Tool Requirements" Section 3 of the Thermo King TriPac Installation Standards Guide (TK 56498).

REQUIRED TOOLS

1. Floor Jack or Motorcycle/ATV Lift
2. Drill Motor and Drill Bit Set
3. 7/8" dia. or 1" Step Reamer (for evaporator drain and controller holes)
4. Hole Saws
 - a. 1" dia. (for fuel tank pickup tube)
 - b. 2-1/2" dia. (for heater inlet/outlet louver)
 - c. 2" dia. (standard size for access hole for evaporator hoses and electrical wiring)
 - d. 3" dia. (optional size for access hole for evaporator hoses and electrical wiring)
 - e. 4-1/4" dia. (for mounting A/C louvers, routing A/C ducts, and heater mounting hole)
5. Reciprocating Saw (return air opening)
6. 1/2" Wrench
7. Level
8. Tape Measure
9. Utility Knife
10. Caulk Gun
11. Digital Meter (204-1079)
12. Refrigerant Leak Detector (204-712)
13. Hose Fitting Tool (204-1045)
14. Hose Cutting Tool (204-677)
15. Heater Priming Harness (204-1144)
16. Shop Vacuum
17. R-134a Gauge Manifold with automotive connectors
18. Vacuum Pump (204-713)
19. Micron Gauge (204-720)
20. Accurate Refrigerant Scale
21. AGM Battery Tester (204-1959)
22. Heavy Duty AGM Battery Charger (204-1923)
23. Laptop Computer (IBM Compatible) with Microsoft Internet Explorer 10.0 or higher installed.
24. USB Adapter Cable (204-2000)



Required Tools and Additional Supplies

ADDITIONAL SUPPLIES (as required)

1. RTV Silicone Sealant
2. Sealer Tape (203-391)
3. Alkyl Benzene Refrigerant Oil (670404TKA for lubricating hose fittings and O-rings)
4. Refrigerant 134a
5. Return air wall louver (approximately 11" x 10")
6. Band Wraps (assorted sizes and lengths)
7. Mounting Clamps #24 and #32 (to secure cables and hoses)
8. Upholstery cleaner
9. Cardboard or blankets (to protect truck interior)
10. Fiberglass repair kit (only used for fiberglass and wood composite floor)

TriPac Envidia and Envidia 2 Component Dimensions

Battery Box Dimensions

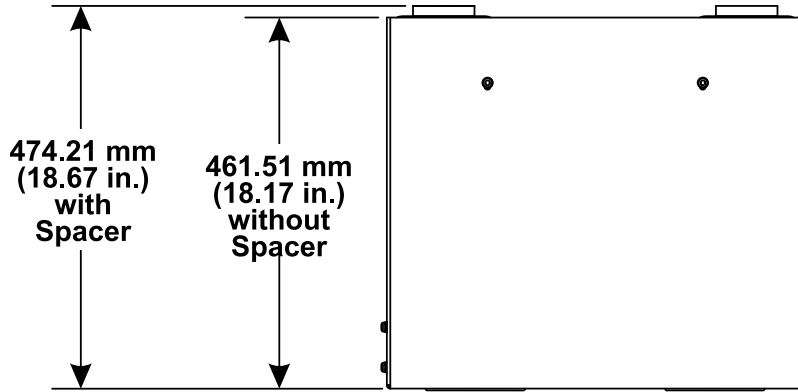

TOP VIEW

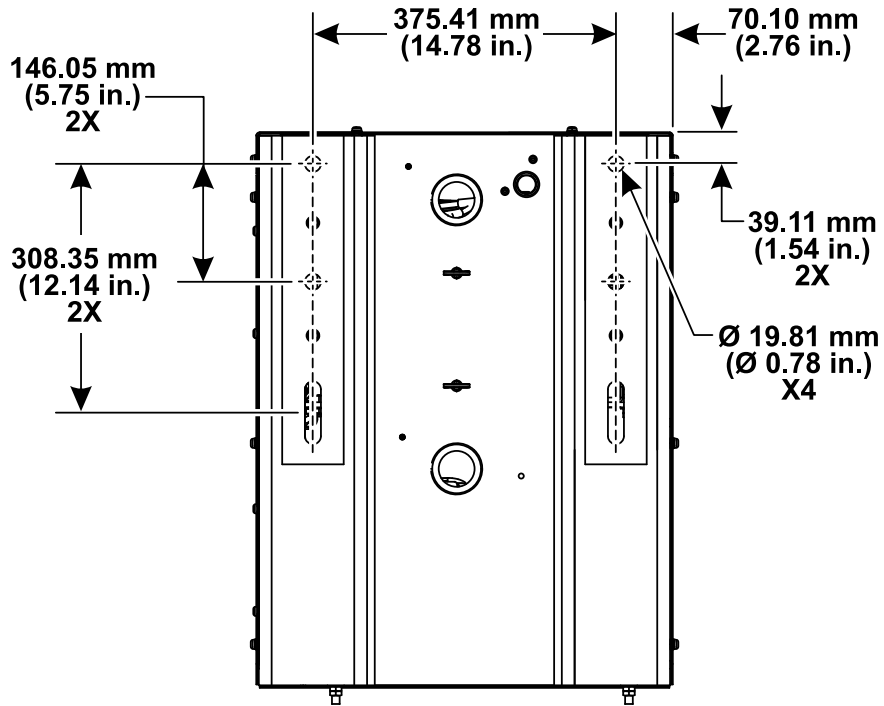

BACK VIEW

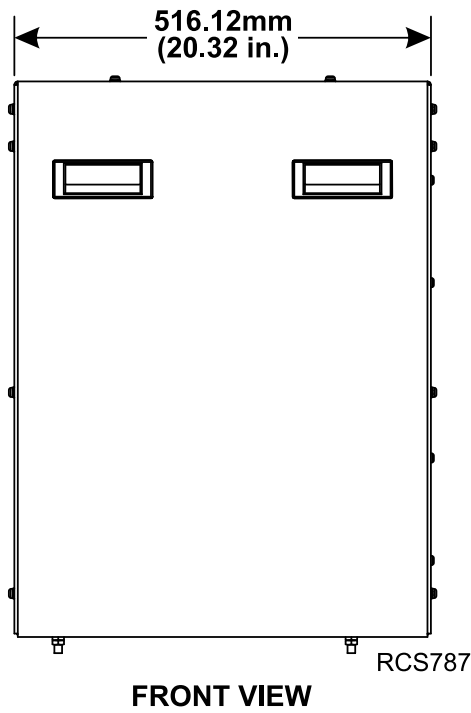
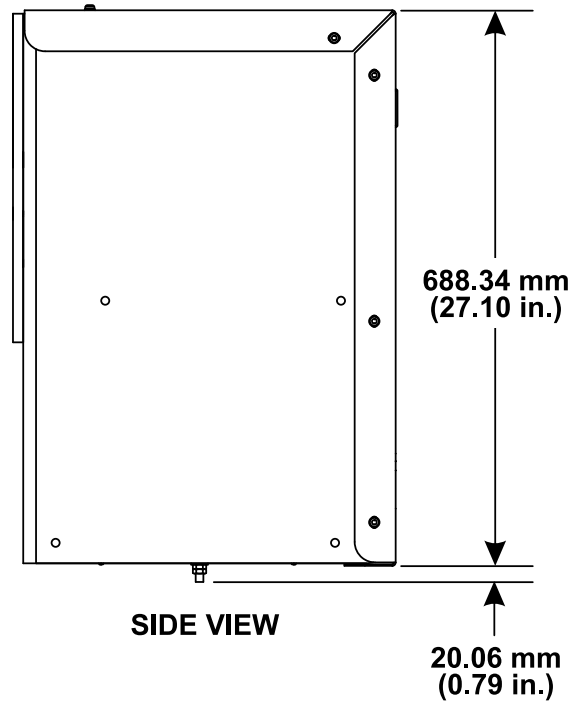

Condenser Dimensions

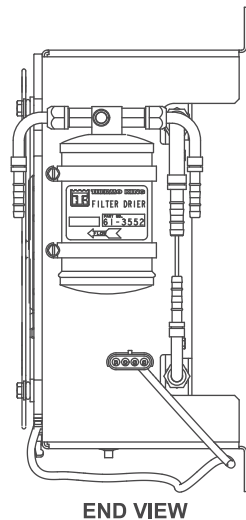
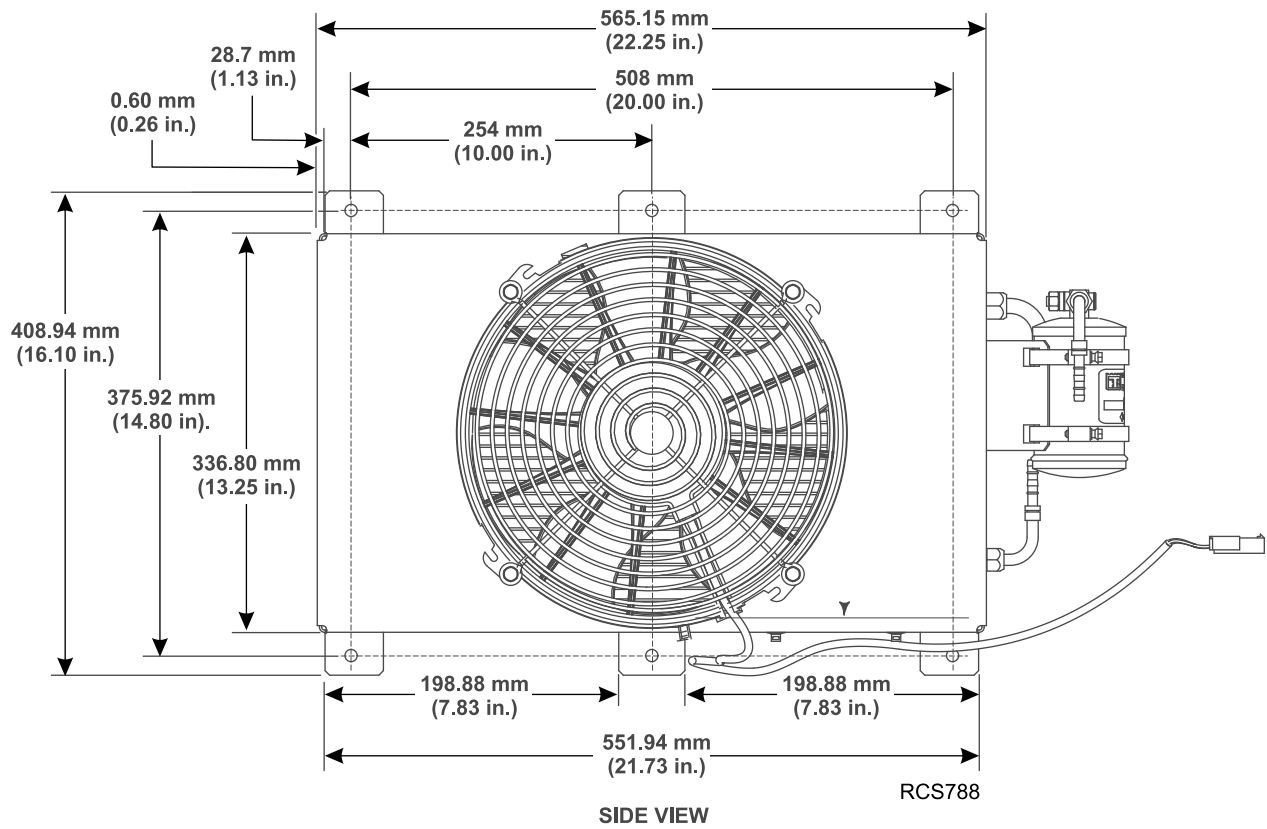
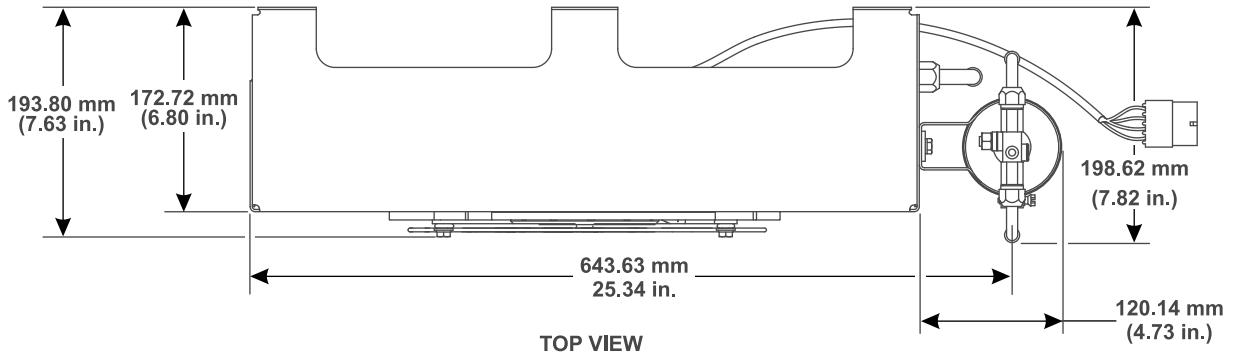

Evaporator/Control Box Dimensions

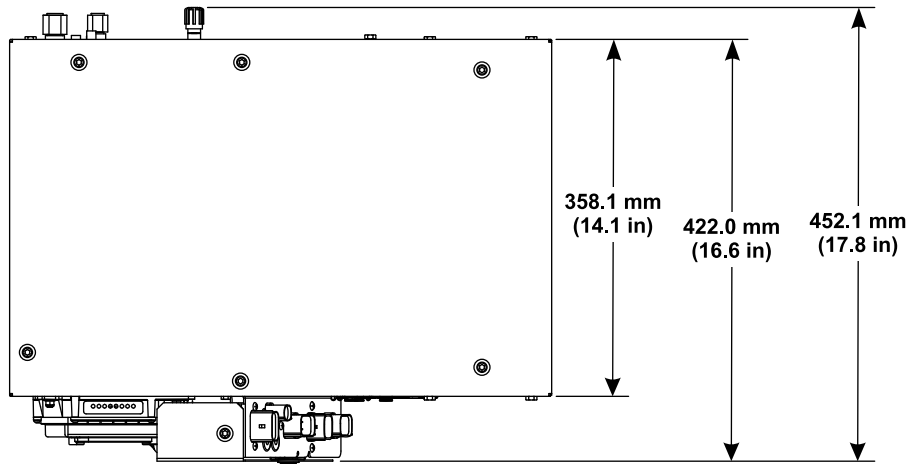

TOP VIEW

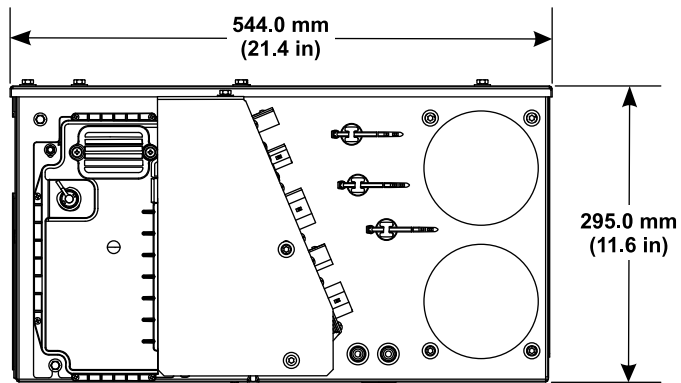

SIDE VIEW

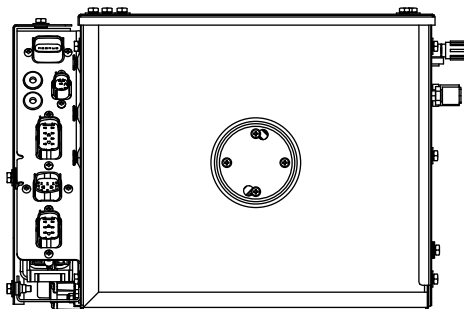

END VIEW

RCS789

HMI Controller Dimensions

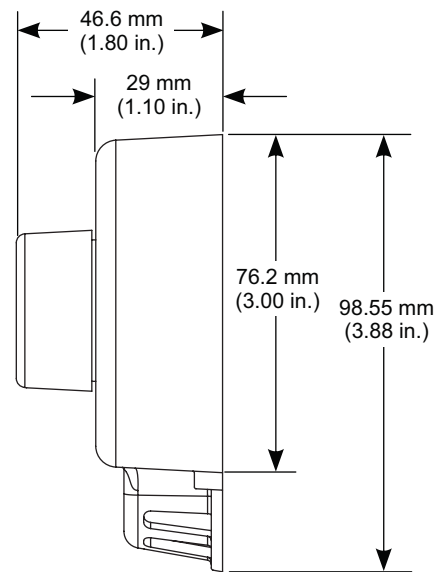
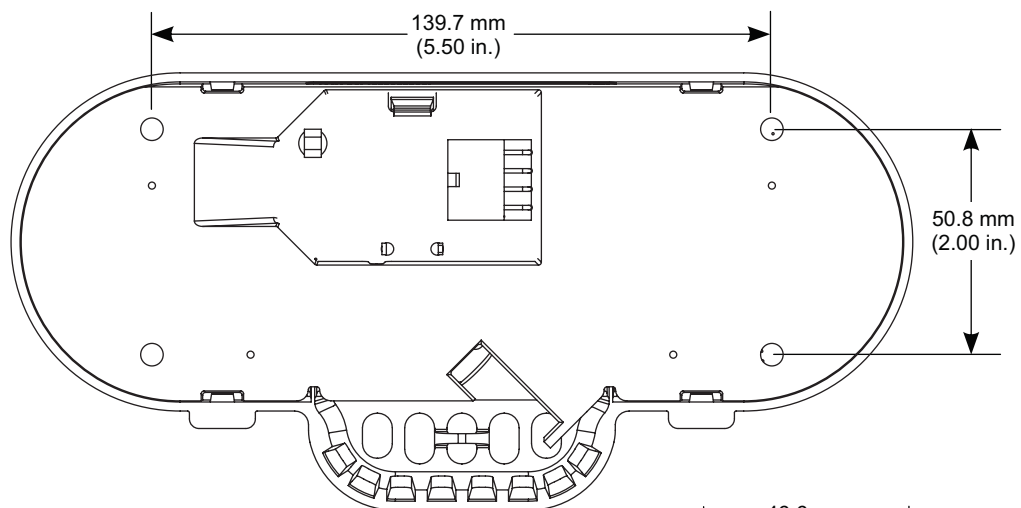
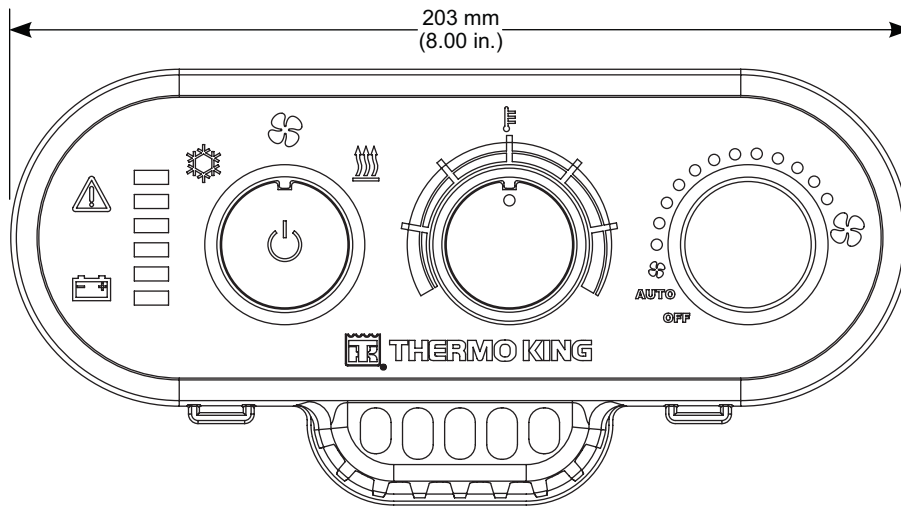



Standard Heater Dimensions

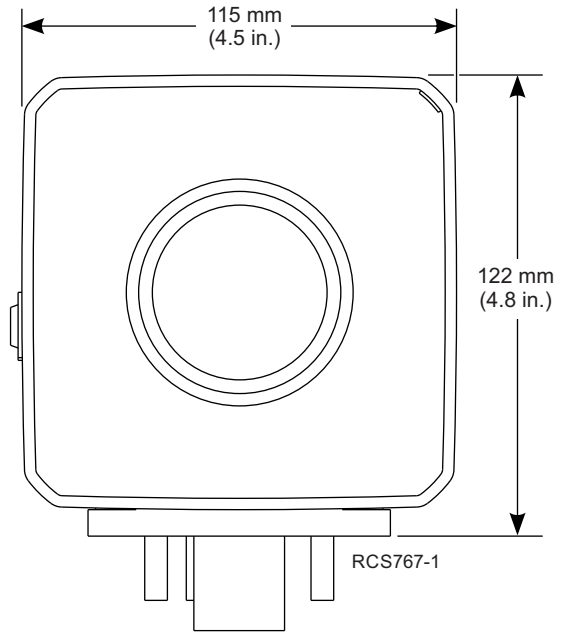
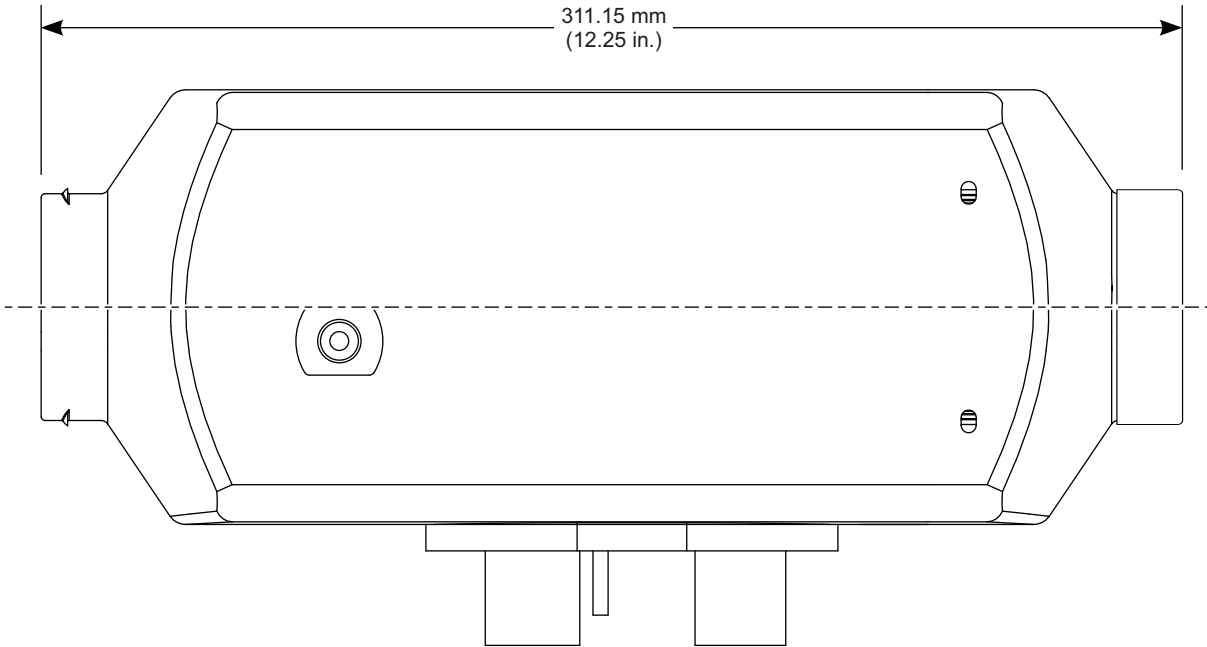

High Output Heater Dimensions

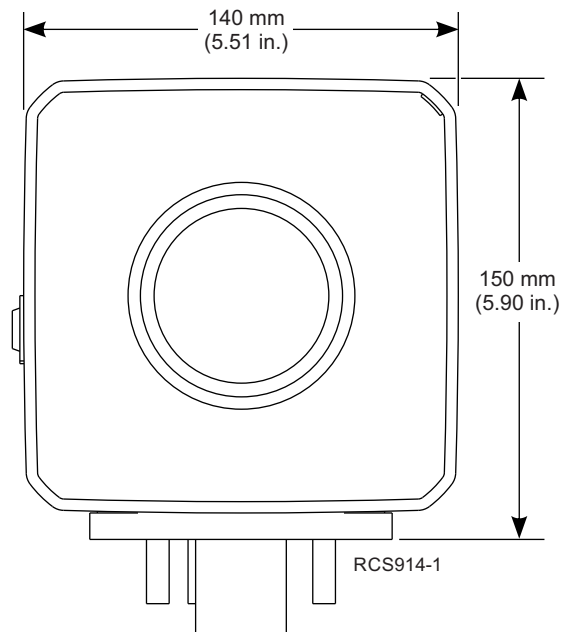
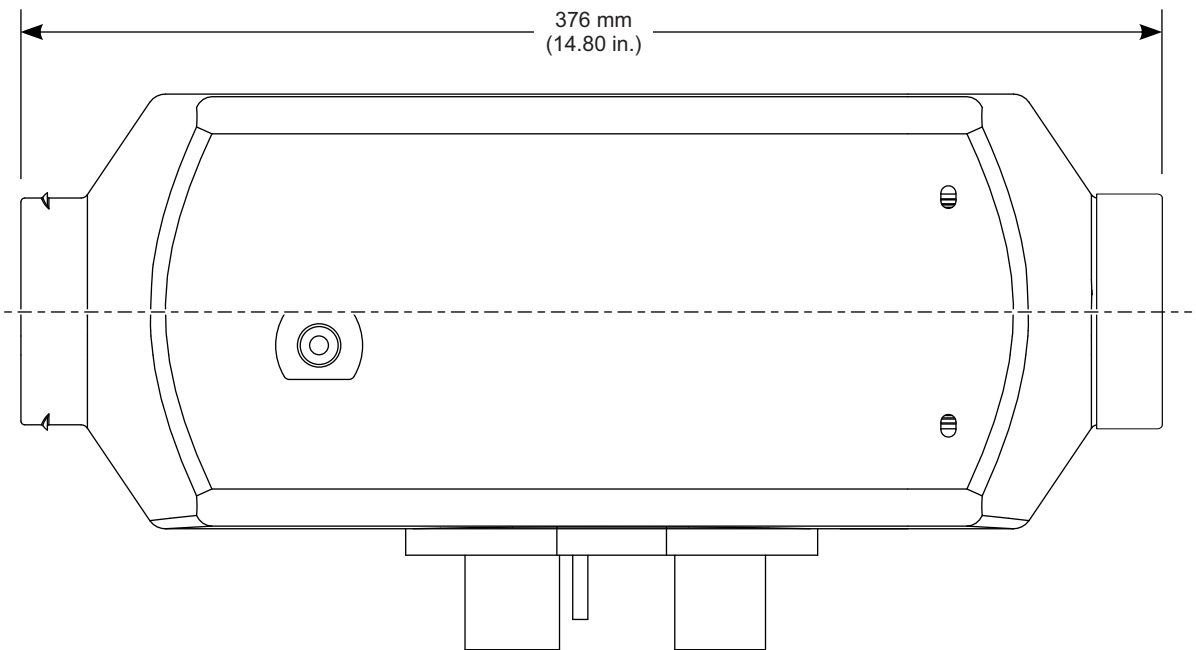

AC/DC Shore Power Converter Dimensions

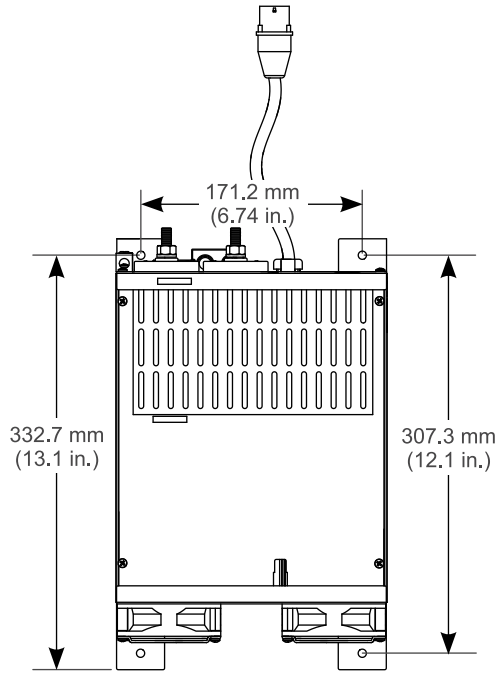

TOP VIEW

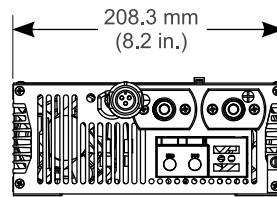

FRONT VIEW

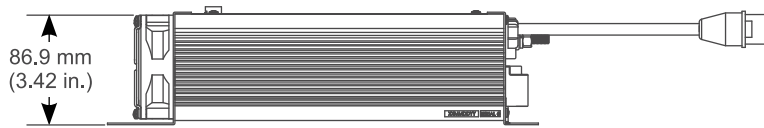

SIDE VIEW

1000 Watt Power Inverter Dimensions

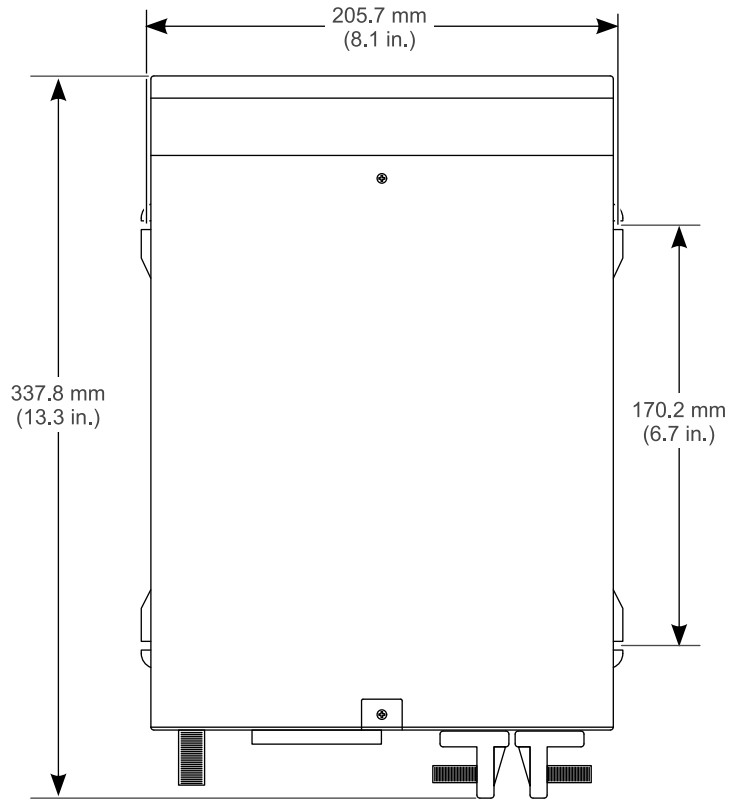

TOP VIEW

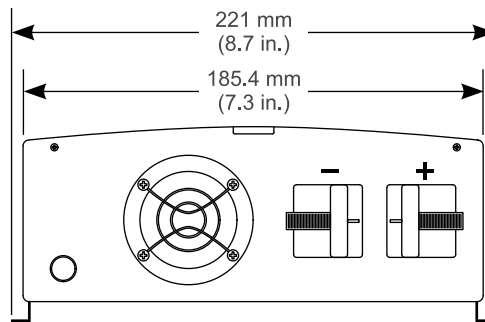

FRONT VIEW

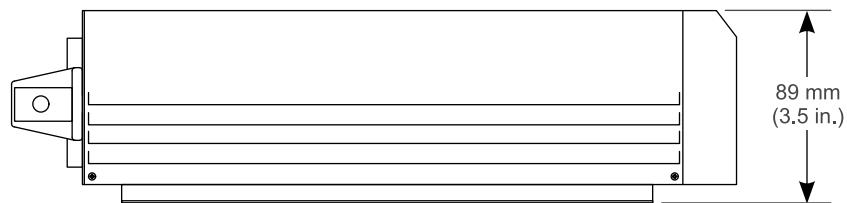

SIDE VIEW

RCS898

Typical Component Locations

***Important:** Proper installation of each component onto the vehicle is critical! Refer to the Thermo King TriPac Installation Standards Guide (TK 56498) before beginning the installation. Adhering to the installation standards will help assure the components are installed correctly and the system operates as designed. It is the responsibility of the installer to follow these standards.*

Figure 1. Typical component locations shown.

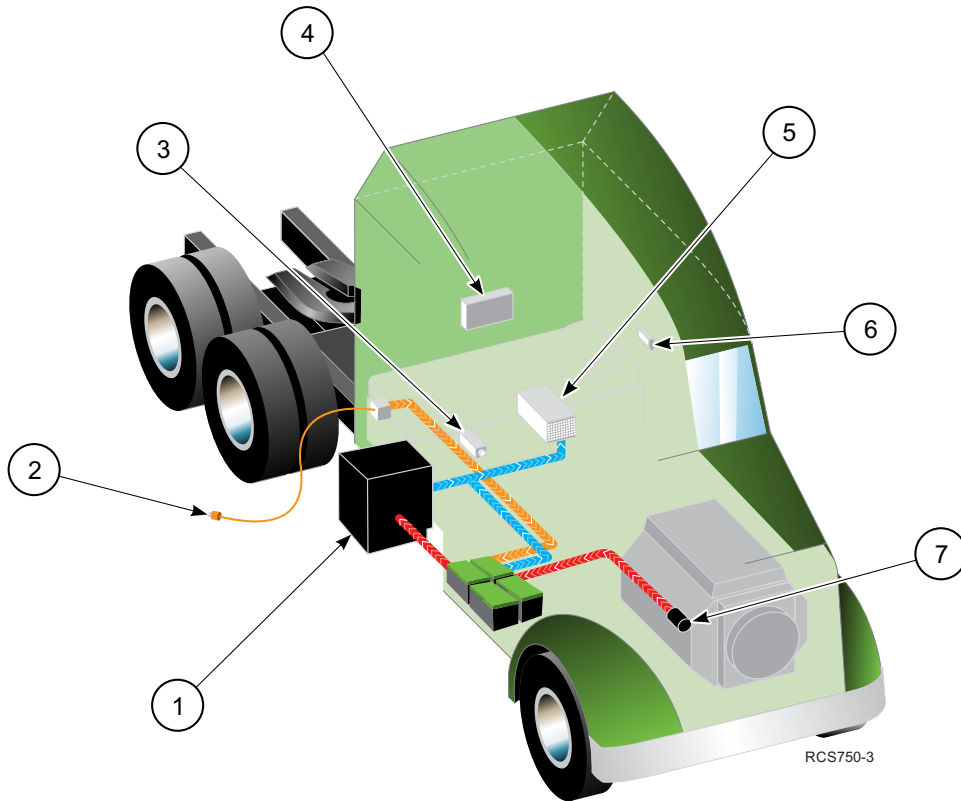

1.	Battery Box — contains four NXT absorbed (AGM) glass mat type batteries.
2.	Shore Power — is an available option that allows the tractor batteries to be charged when shore power is available.
3.	Heater —is an available option..
4.	Condenser — the air conditioning condenser is mounted on the rear exterior of the truck cab.
5.	Evaporator / Control Box — the combination air conditioning evaporator and control box is typically installed under the bunk in the truck cab sleeper compartment. Air duct hoses from the evaporator provide conditioned air to the sleeper compartment.
6.	HMI Controller — the Human Machine Interface (HMI) controller is installed in the truck cab, typically on a wall in the sleeper compartment.
7.	270A Alternator — is required for optimum performance and driver comfort.

Battery Box Installation

Important: See “Battery Box Installation Standards” in Section 6 of the Thermo King TriPac Installation Standards Guide (TK 56498). **THESE STANDARDS MUST BE FOLLOWED!**

Standard Installation Method – Mounting Claws

Special Tools Required
Modified Floor Jack or Motorcycle/ATV Lift
1/2" Drive Torque Wrench

Refer to the illustration on the following page.

1. Remove cover from battery box to access hardware securing box to shipping crate.
2. Place battery box onto a modified floor jack or motorcycle/ATV lift by:
 - a. Installing forged lifting eyebolts, washers and nuts securely into the holes provided on top of battery box.
 - b. Place cardboard, shop rags, etc. onto jack/lift to prevent damage to battery box.
 - c. Use forged clevises attached to an overhead lifting device to place battery box onto lift.

Note: 1.00 in. Battery Box Spacer Kit is available for use with claw mounts.

3. Using the lift, raise battery box into position and install 3/4" bolts and washers through mounting claws and into rear of battery box. Mounting bolt threads must extend into the battery box.
4. Loosely install retainers and locking nuts inside battery box.

Important: DO NOT OIL THE BOLT THREADS!

Important: *The following steps are critical and must be followed to ensure the safe installation of the battery box to the truck’s frame.*

5. With battery box still supported by a lift:
 - a. Push battery box up tight to truck’s frame.
 - b. Adjust height of box so both **top** and **bottom** mounting claws and bolts are positioned flat on frame.
 - c. Review (**Detail A**) - Lightly tighten mounting hardware only enough to remove excess play.
6. Using a torque wrench, torque mounting bolts in four step increments starting with top bolts, then bottom bolts.
 - a. **STEP 1** - Torque top, then bottom mounting bolts to 25 ft-lb. (33.9 Nm).
Important: STOP and verify all mounting claws and bolts remained flat on frame (**Detail A**). If they are not, loosen bolts, adjust as necessary and retighten again to 25 ft-lb. (33.9 Nm).
 - b. **STEP 2** - After first step is successfully completed, torque top, then bottom bolts to 50 ft-lb. (67.8 Nm).
 - c. **STEP 3** - Next, torque top, then bottom bolts to 100 ft-lb. (135.6 Nm).
 - d. **STEP 4** - Finally, recheck all bolts to confirm they are torqued to 100 ft-lb. (135.6 Nm).
7. Remove the support lift and visually inspect installation for the following:
 - a. Mounting claws and bolts are **correctly** installed. They should be square and flat on the frame (**Detail A**).
 - b. If any mounting claws and bolts are **improperly** installed on the frame (**i/e. they resemble Details B & C**) - **adjust as necessary**.
 - c. Damaged, deformed or cracked components during installation - must be **replaced immediately**.

Figure 2. Standard Installation Method – Mounting Claws

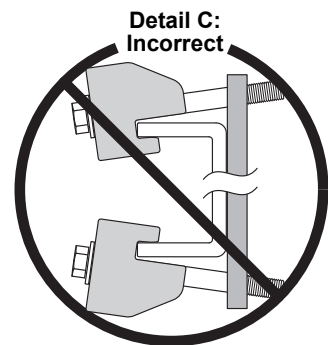
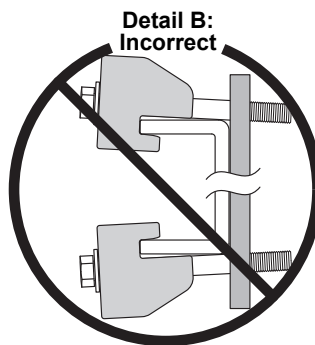
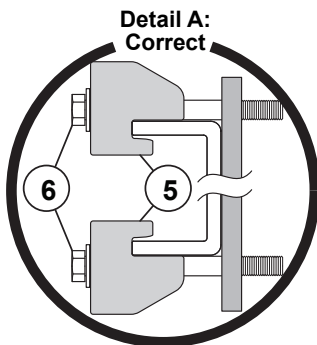
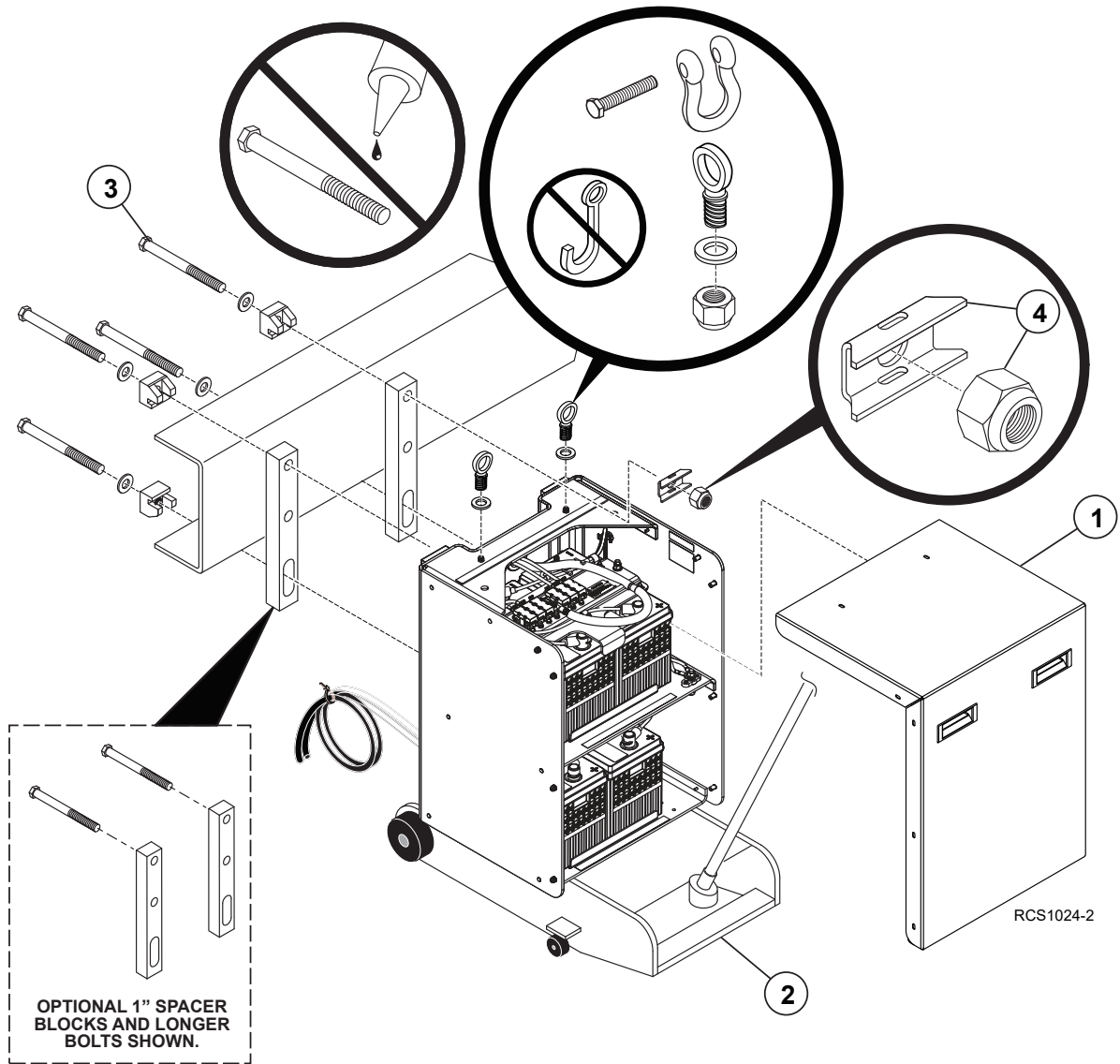



Optional Installation Method – Direct Mount

Important: DO NOT weld or drill holes in the top or bottom flanges of the truck's frame. Serious structural damage could occur to the frame! Consult your chassis manufacturer for further information.

Note: Direct mounting of the battery box requires Direct Mount Bolt Kit (800461).

Refer to the illustration on the following page.

1. Remove cover from battery box to access hardware securing box to shipping crate.

Important: The two upper batteries must be removed.

2. Place battery box onto a modified floor jack or motorcycle/ATV lift by:
 - a. Installing forged lifting eyebolts, washers and nuts securely into the holes provided on top of battery box.
 - b. Place cardboard, shop rags, etc. onto jack/lift to prevent damage to battery box.
 - c. Use forged clevises attached to an overhead lifting device to place battery box onto lift.

Note: If the 1-1/2" or 2- 1/2" optional spacers are being used, refer to the installation instructions included with the spacer kit.

3. **DETAIL A** – From the backside of battery box, insert 3/4" x 3.00" long bolts and washers through the slotted holes and into the battery box.

Important: DO NOT OIL THE BOLT THREADS!

- a. From inside battery box, install washers and locking nuts into inner frame channel and hand tighten hardware.
 - b. Position bolts to bottom of slots and tighten to 200 ft-lb. (270 Nm).
4. **DETAIL B – BEFORE DRILLING HOLES:** Observe the positioning of existing OEM fasteners on the truck's frame. The four fasteners used in this Direct-Mount Option need to be located on the tractor's frame no higher and no lower than any existing OEM fasteners.
 - a. Measure and mark location of the four mounting holes on truck's frame. Drill four 25/32" (20 mm) holes in frame.
 5. Rise battery box into position and align the four mounting holes with the holes in truck's frame.

- a. From the backside of the truck's frame, insert bolts and washers through the holes and into the battery box.

Important: DO NOT OIL THE BOLT THREADS!

- b. From inside the battery box, install washers and locking nuts into the inner frame channel and hand tighten hardware
6. With the battery box still supported by a lift and level with the tractor's frame, use a torque wrench and torque the four frame mounting bolts in three step increments as described below:
 - a. STEP 1 - Torque top then bottom bolts to 50 ft-lb. (68 Nm).
 - b. STEP 2 - Torque top then bottom bolts to 100 ft-lb. (135 Nm).
 - c. STEP 3 - Torque top then bottom bolts to 200 ft-lb. (270 Nm).

Important: DO NOT OVER-TORQUE THE MOUNTING BOLTS!

7. Remove the support lift.
8. Reinstall the two upper batteries removed early.

Figure 3. Optional Installation Method – Direct Mount.

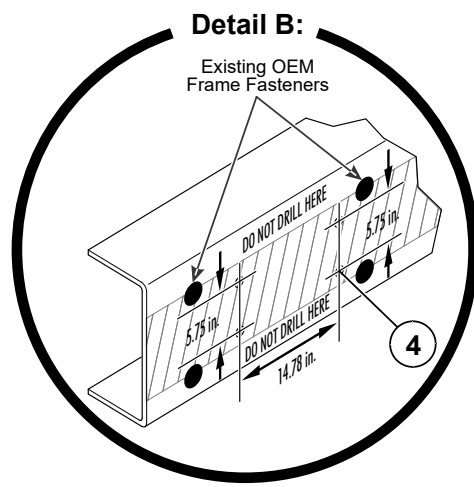
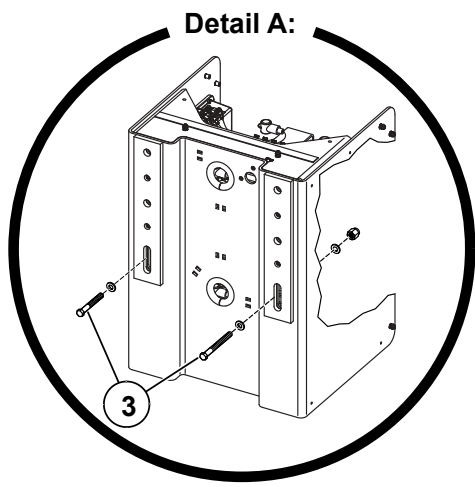
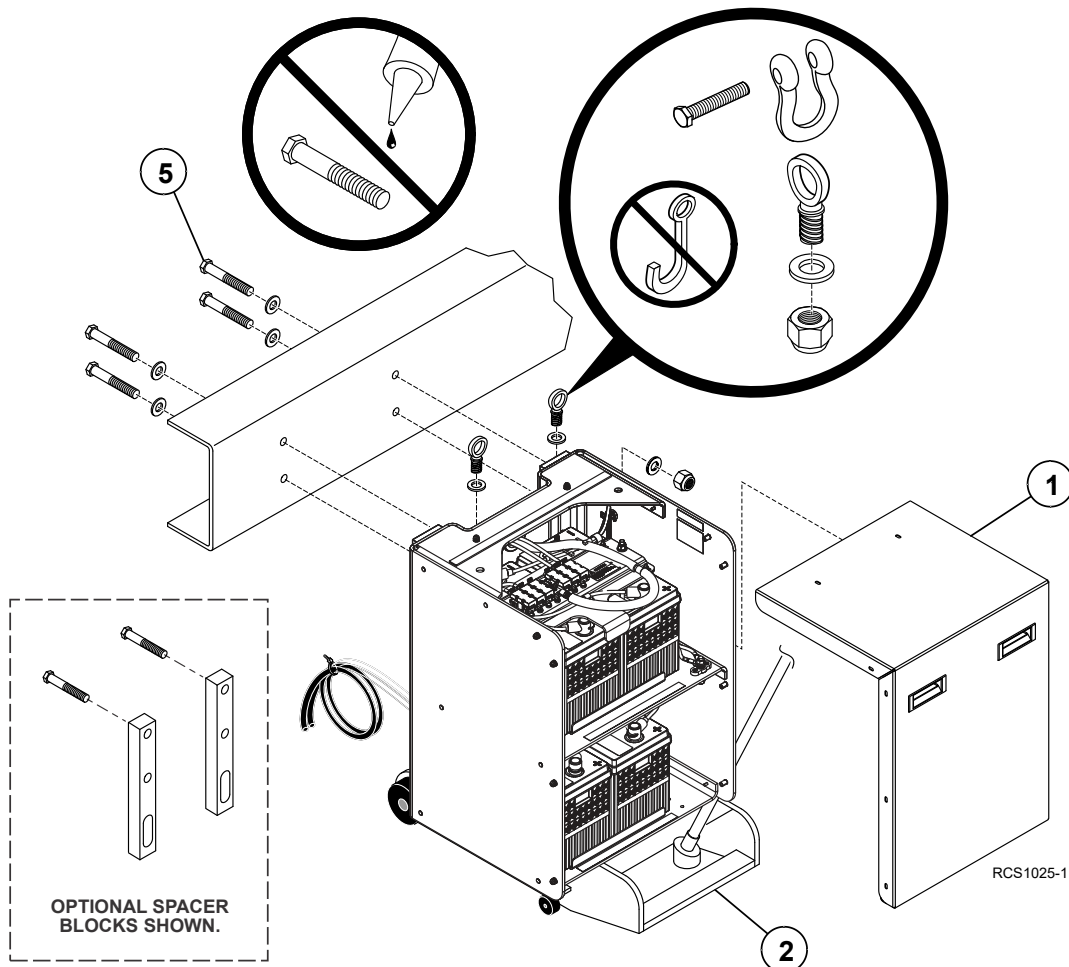

Receiver Drier Installation

Important: See “Receiver Drier Installation Standards” and “Refrigeration Hose and Fittings Standards” in Section 8 of the Thermo King TriPac Installation Standards Guide (TK 56498). THESE STANDARDS MUST BE FOLLOWED!

Special Tools Required
Hose Fitting Tool (204-1045)
Hose Cutting Tool (204-677)
Alkyl Benzene Refrigerant Oil (670404TKA)
Torque Wrench

Place condenser coil onto workbench and assemble the following components:

1. Install receiver drier bracket onto condenser housing with supplied 1/4-20 mounting hardware and tighten securely.
2. Attach the two large hose clamps to the bracket.
3. Secure receiver drier to the bracket with the hose clamps and tighten securely.

Important: The refrigerant flow arrow must be visible and pointing in the correct direction per the illustration on the following page.

Figure 4. Install receiver drier onto condenser as shown.

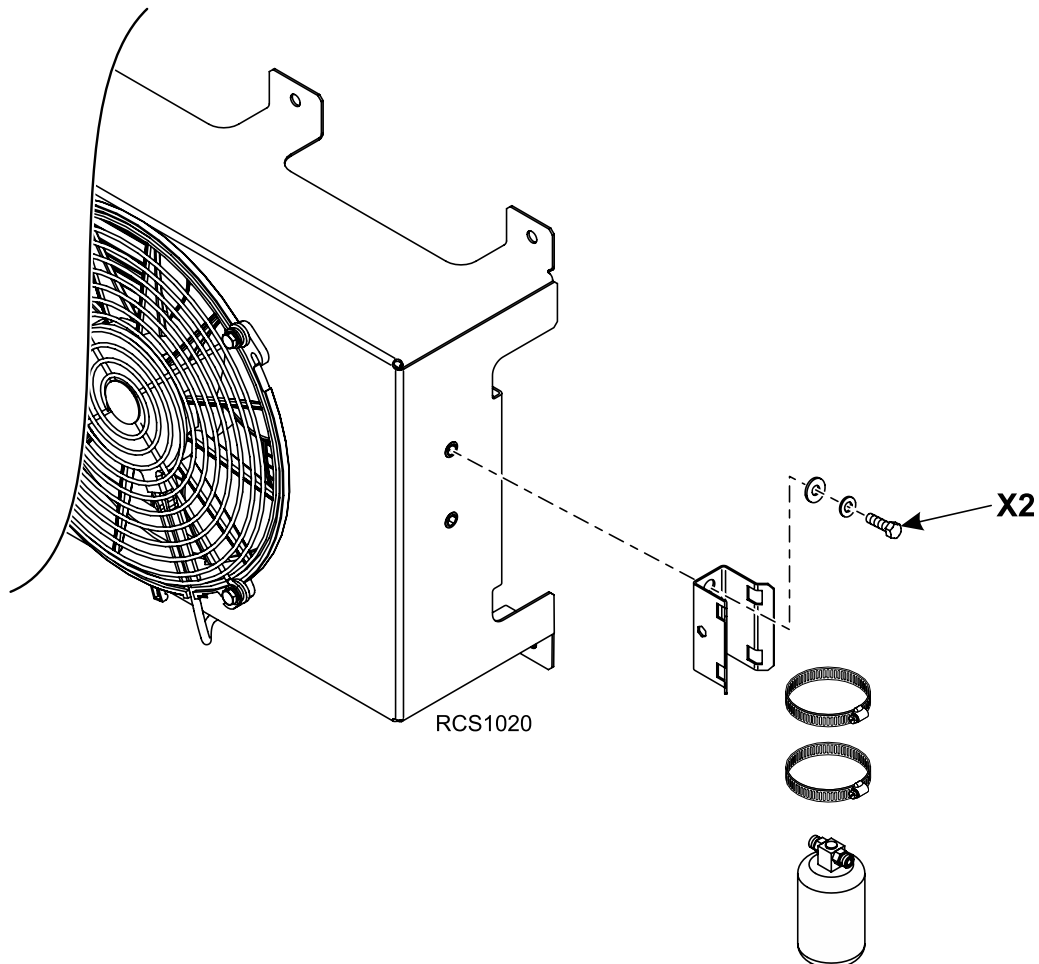

4. Fabricate and install a #4 hose (5.00 in. long) with two 90 degree #4 fittings from the **INLET** fitting of the drier to the bottom **OUTLET** fitting on the condenser.
5. Fabricate the other hoses as shown and tighten all fittings to the torque specs shown.

Fitting Size	Torque Specifications
#6 (3/8")	11-13 ft-lb (15-17 Nm)
#8 (1/2")	15-20 ft-lb (20-27 Nm)

Figure 5. Install hoses onto receiver drier and condenser as shown (note flow direction arrow).

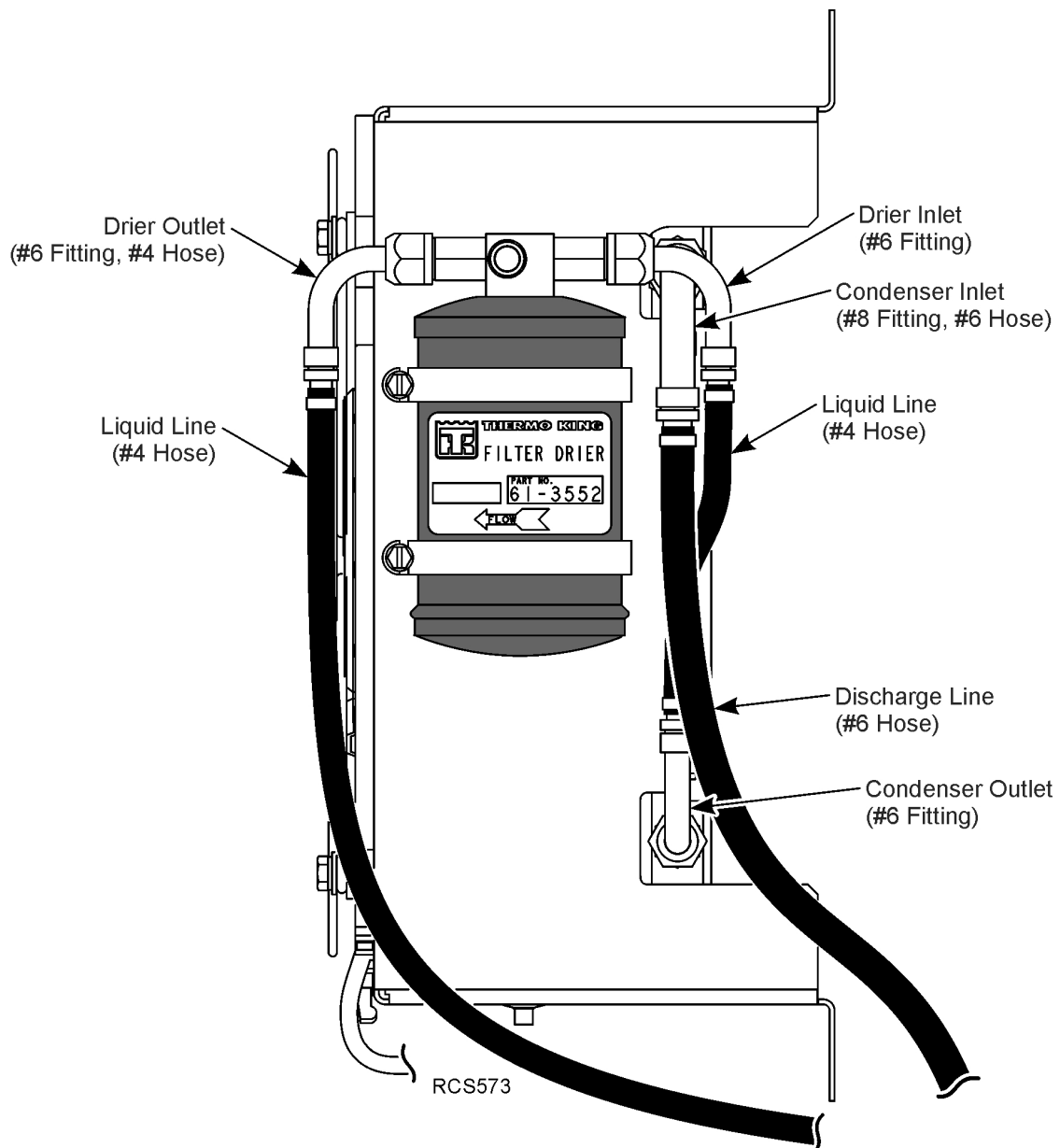

A/C Condenser Installation

Important: A properly installed condenser onto the truck's cab is critical. See "Condenser Installation Standards" in Section 6 of the Thermo King TriPac Installation Standards Guide (TK 56498). THESE STANDARDS MUST BE FOLLOWED!

Special Tools Required
Template — Condenser Assembly
Tape Measure
Level
Drill Motor
3/8" Drill Bit
Caulk Gun and RTV Silicone Sealant

Important: Before drilling any holes in truck, check for interference with internal wires, support members or interior panels. Drilling into interior support members could void truck's OEM warranty.

Important: Condenser must be installed in correct orientation for maximum air conditioning performance. See "Orientation Standards" in Section 6 of the Thermo King TriPac Installation Standards Guide (TK 56498).

1. Measure and mark exterior center line of sleeper.
2. Position supplied template onto exterior of sleeper making sure it is level and centered. Mark and drill 3/8" mounting holes and remove template.
3. Apply a bead of RTV silicone around each of the six mounting holes.
4. Install condenser assembly with supplied 3/8" stainless mounting hardware.
5. Assure all six mounting tabs are in contact with truck body. Use spacers (installer supplied) as required.
6. Tighten hardware securely.

Figure 6. Typical A/C Condenser installation shown.

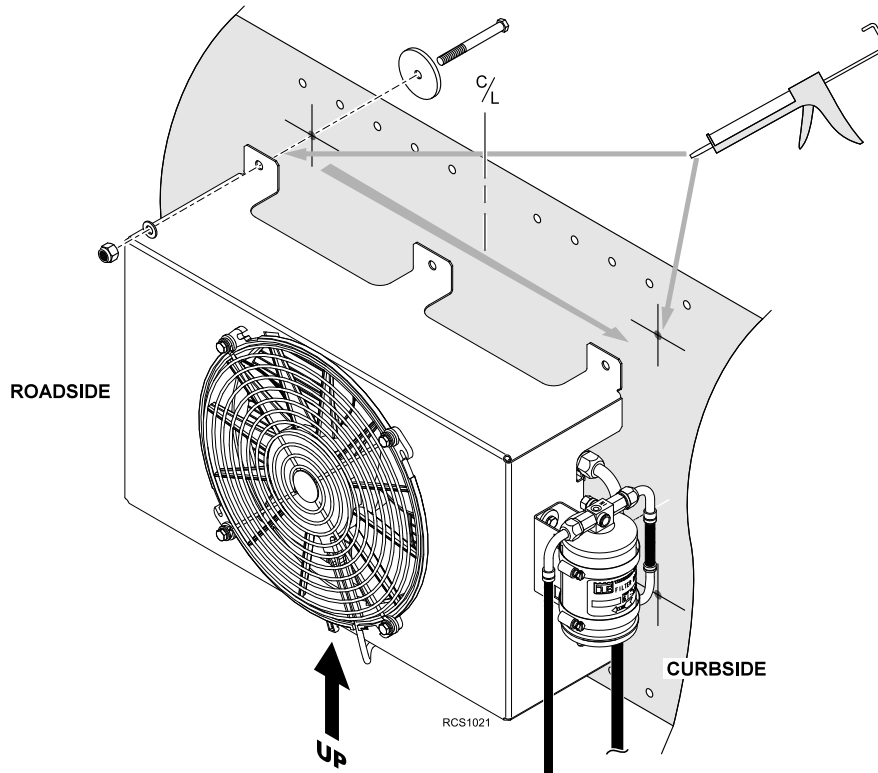

A/C Evaporator / Control Box Installation

Important: See “Evaporator/Control Box Installation Standards” in Section 6 of the Thermo King TriPac Installation Standards Guide (TK 56498). **THESE STANDARDS MUST BE FOLLOWED!**

Special Tools Required
Template — Evaporator/Control Box
Drill Motor
1/4” Drill Bit
7/8” Step Reamer
2” dia. Hole Saw (for standard installation)
3” dia. Hole Saw (for optional installation)
Reciprocating Saw
Caulk Gun and RTV Silicone Sealant
Sealing Tape (203–391)
Fiberglass Cloth and Resin Kit (if required)

Using the Supplied Template

The template represent the amount of area needed to accommodate the Evaporator/Control Box and also the locations for the mounting feet, drain holes and two 2” access holes. If there is not enough room for the 2” access hole near the Controller, an optional single 3” access hole can be cut near the refrigeration hoses. The controller harnesses will wrap around the end of the Evaporator/Control Box.

Figure 7. Evaporator Template shown.

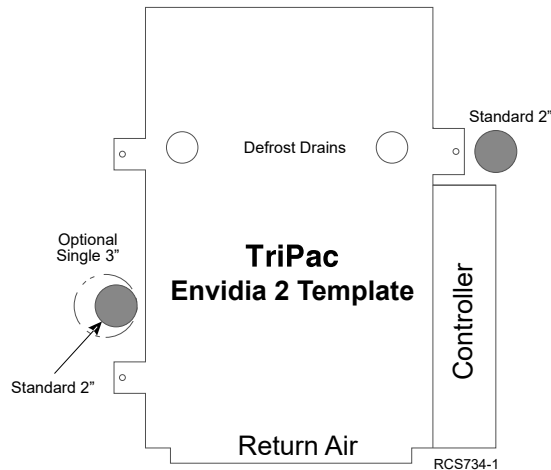

The following are important access hole requirements:

- Actual location of the 2” access holes will be determined by your particular sleeper construction, including OEM internal floor supports, electrical wiring, etc.
- Before drilling any holes, check for interference with internal electrical wires, supports or interior panels. Avoid drilling into the truck’s support members.
- Floor made from fiberglass covered wood construction require the edges of the access holes to be completely sealed with fiberglass and epoxy resin.
- An optional 3” access hole on the refrigerant line side may be used if mounting location does not permit a access hole on the controller side of the Evaporator/Control Box.

A/C Evaporator / Control Box Installation

Note: This installation requires two-persons or mechanically assisted lift. It is not necessary to remove the Evaporator/Control Box cover to complete a system installation.

1. Position template with **RETURN AIR** flush with bulkhead if possible.

Important: Confirm top edge of bulkhead does not interfere with filter removal. Set Evaporator/Control box back from bulkhead if necessary to allow for filter removal.

Figure 8. Evaporator shown set back to allow for filter removal.

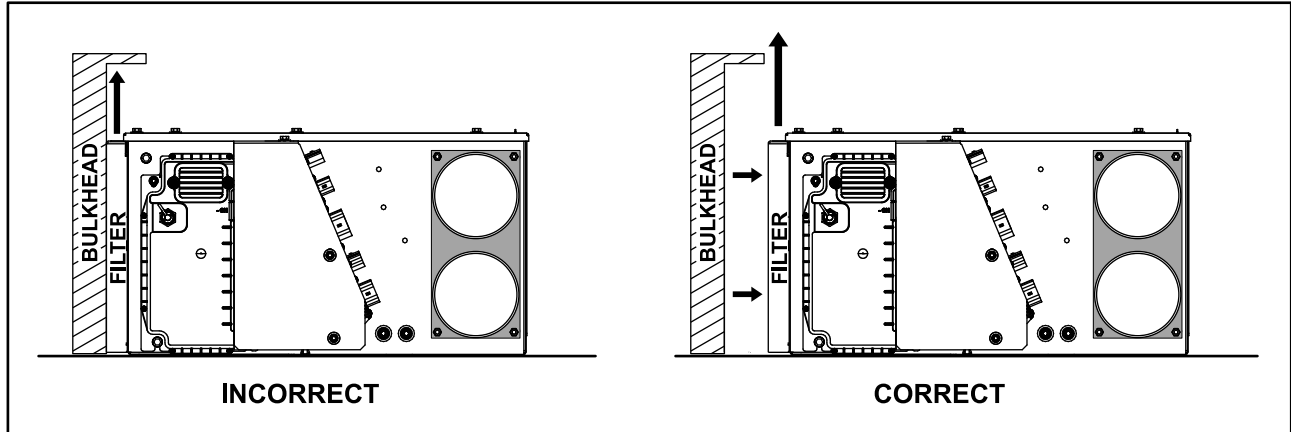

RCS1060

- a. Mark location of the 7/8" evaporator drain holes and 2" access holes and remove the template.
 - b. Drill a 1/4" pilot hole for drain holes followed by a 7/8" step reamer.
 - c. Drill 2" access holes. Holes may also be located outside the template area as shown.
2. Cut and install a piece of split loom (or similar) around the inside edge of the 2" access holes to provide protection for hoses and wiring.

Figure 9. Typical installation using template shown.

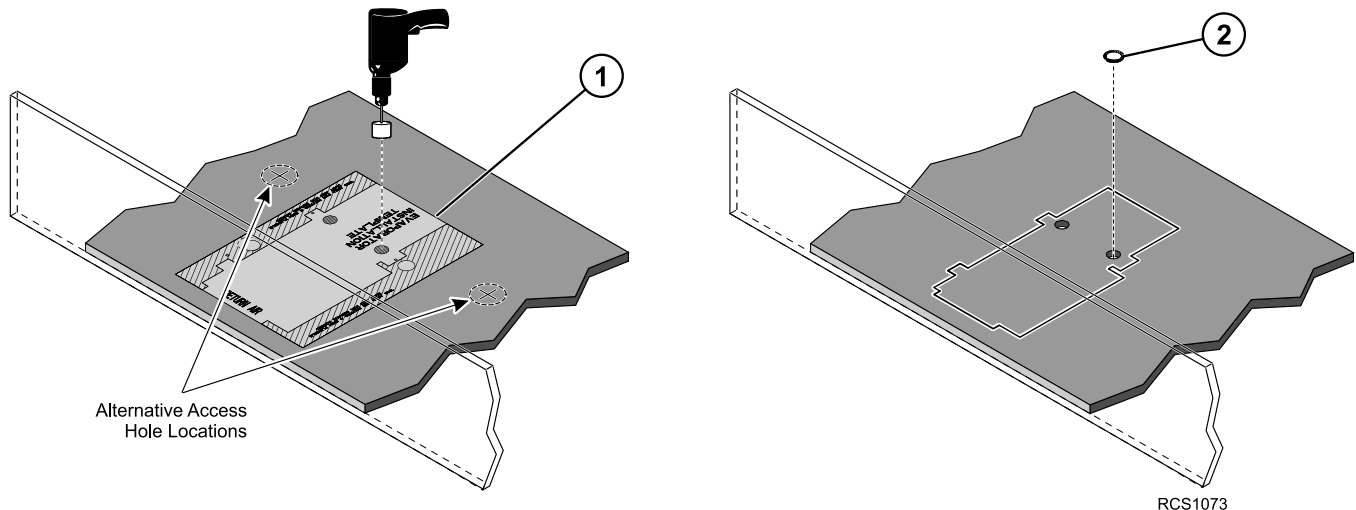

RCS1073

3. Install return air filter support with filter to front of Evaporator/Control Box.
4. Set evaporator in place and determine where return air opening needs to be located on bulkhead. Leave clearance for filter removal.
5. Mark return air opening (11.00 in. x 10.00 in.).
 - a. Cut opening in bulkhead.
 - b. A return air grille (installer supplied) can be installed to the bulkhead if desired.

Note: A 12" x 12" return air grille is recommended or 10" x 12" for some applications. Whichever grille is installed, it should not block any of the air inlet opening.

6. Install the defrost drain tubes to the base of the evaporator before mounting to the floor.

Figure 10. Defrost drain tubes shown installed.

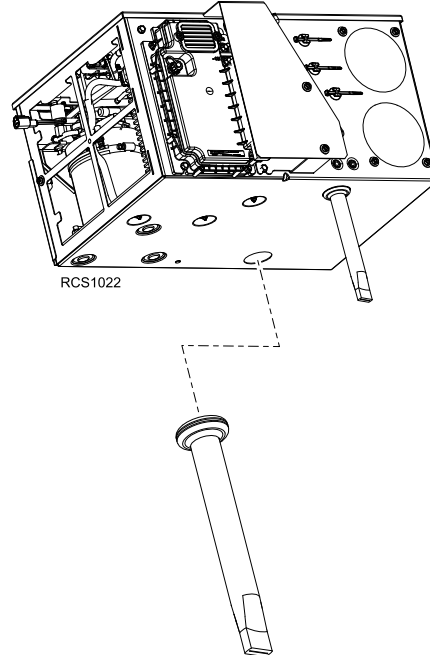

7. Loosely install the three mounting tabs onto the evaporator.
 - a. Secure the evaporator to the floor securely with TEK screws.
8. From underneath the sleeper:
 - a. Seal around drain tube access holes with sealing putty or silicone sealant.
 - b. Apply silicone sealant around the three evaporator mounting screws.
 - c. Seal any unused holes, cracks, or visible air gaps that might be found.

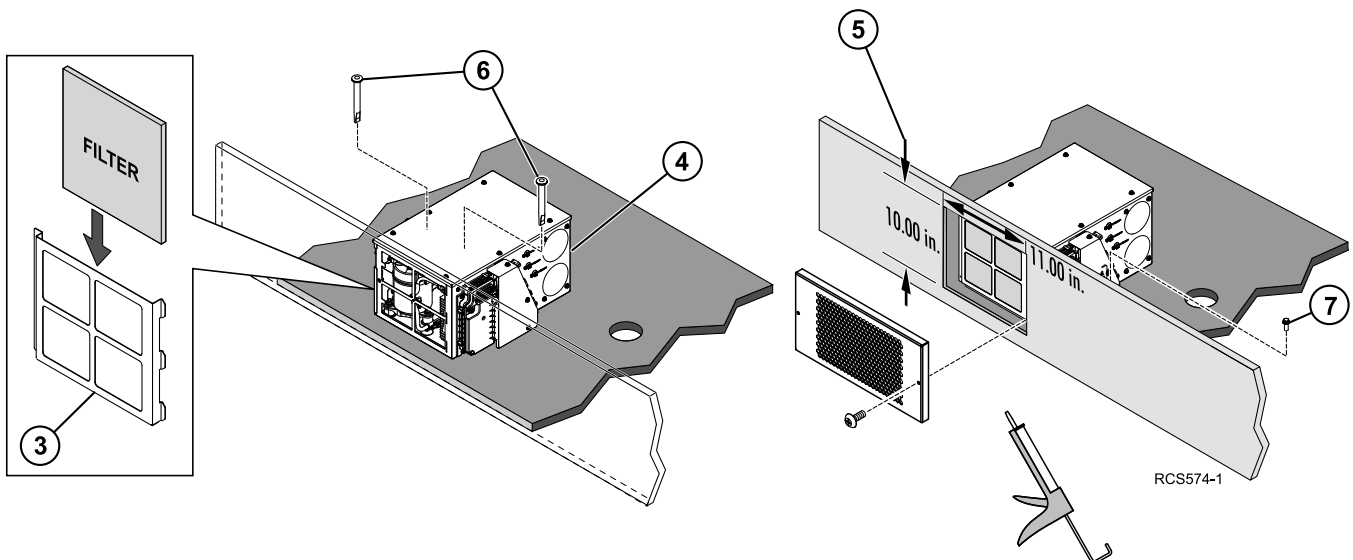

A/C Hose Installation

Important: See “Refrigerant Hose and Fittings Standards” in Section 8 of the Thermo King TriPac Installation Standards Guide (TK 56498). **THESE STANDARDS MUST BE FOLLOWED!**

Note: The Evaporator/Control Box system has a Nitrogen holding charge of 5 PSI. This holding charge can safely be vented into the atmosphere.

Special Tools Required
Hose Fitting Tool (204-1045)
Hose Cutting Tool (204-677)
Alkyl Benzene refrigerant oil (670404TKA)
Torque Wrench

DISCHARGE LINE INSTALLATION

1. Fabricate a **#6 hose** with a 90 degree fitting and connect to the fitting on the **condenser coil inlet** (top connection). Tighten fitting to 15-20 ft-lb (20-27 Nm).
2. Route hose up through 2” access hole in tractor floor near Evaporator/Control Box air conditioning fittings.
3. Cut hose to length, install 90 degree fitting with service port and attach to the **large** fitting on Evaporator/Control Box. Tighten fitting to 15 to 20 ft-lb (20 to 27 Nm).

LIQUID LINE INSTALLATION

4. Fabricate a **#4 hose** with a 90 degree fitting and attach onto **receiver liquid line outlet** fitting on receiver drier. Tighten fitting to 11 to 13 ft-lb (15 to 17 Nm).
5. Route hose up through 2” access hole in tractor floor near Evaporator/Control Box air conditioning fittings.
6. Cut hose to length, install 90 degree fitting and attach onto **small** fitting on Evaporator/Control Box. Tighten fitting to 11 to 13 ft-lb (15 to 17 Nm).
7. Secure all hoses adequately with clamps or band wraps.

Figure 11. Refrigeration hose connections and hose sizes shown.

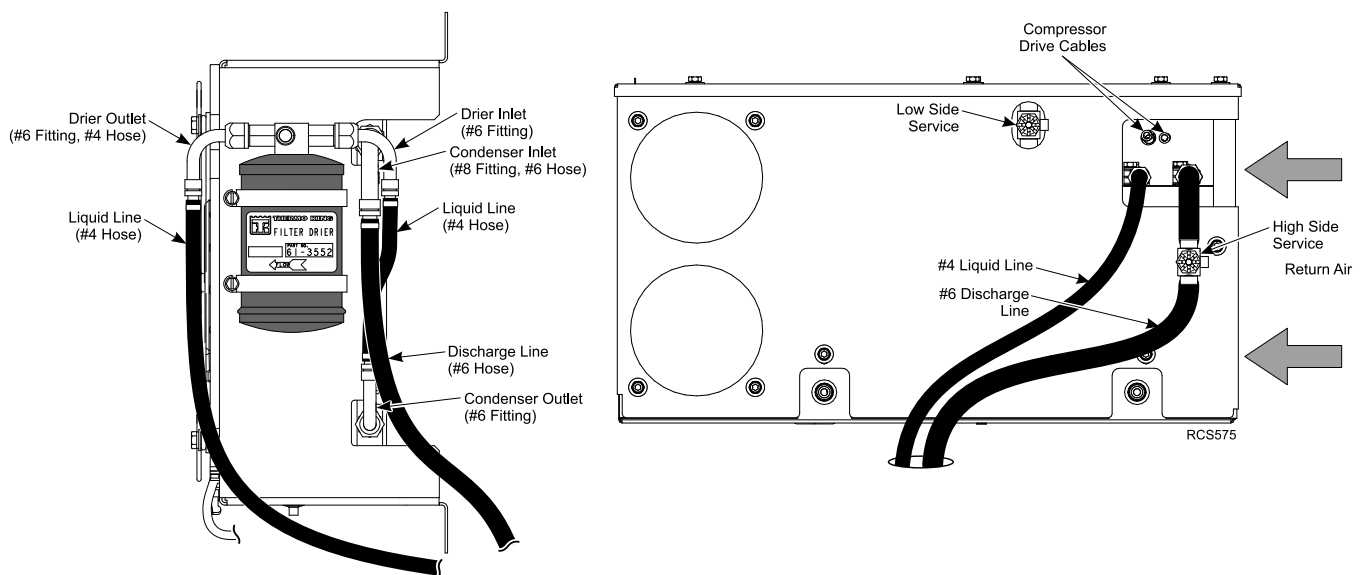

A/C System Evacuation and Leak Check Procedures

Important: See “System Evacuation Standards” in Section 12 of the Thermo King TriPac Installation Standards Guide (TK 56498). **THESE STANDARDS MUST BE FOLLOWED!**

Note: Always use recommended vacuum equipment. Before each use, check that there are no leaks in the vacuum equipment either in the pump itself or in the hoses. The oil in the evacuation station vacuum pump should be changed after each use.

Special Tools Required
Vacuum Pump (204-713 or equivalent)
Micron Gauge (204-720)
Refrigerant Leak Detector (204-712)
Gauge Set with R134a Adapters

EVACUATION PROCEDURES

Note: Continue with the installation (heater, electrical, etc.) while the system is being evacuated.

1. Connect gauge manifold to suction and discharge service ports at the Evaporator/Control Box
2. Connect service line of the gauge manifold to vacuum pump and micron gauge.
3. Open gauge manifold and vacuum pump valves and gauge manifold hand valves.
4. Start vacuum pump and evacuate until system reaches 500 microns.
5. Once system reaches 500 microns, continue evacuation for **one additional hour**.
6. Close vacuum pump isolation valve, switch off pump. Check that the gauge reading for the system does not exceed **2000 microns** in the following five minutes. If vacuum level exceeds 2000 microns before five minutes, and continues to rise, proceed to the **Leak Check Procedures** section. If it stops in a vacuum continue to evacuate for an additional 30 minutes.
7. If vacuum level remains below 2000 microns for 5 minutes the system is leak free and ready to be filled with refrigerant.
8. Close manifold hand valves and remove evacuation equipment.

LEAK CHECK PROCEDURES

9. Add vapor R-134a to the unit until bottle pressure is reached.
10. Thoroughly leak check the system with an electronic leak detector.
11. If leaks are found, recover leak check charge.
12. Repair any leaks and re-evacuate system.

D2/D4 Heater Installation (Heat Option)

Important: Correct installation of the TriPac diesel-fired heater system is critical to ensure safe and proper operation. ***BEFORE*** installing the heater, read the heater manufacturer’s manuals included with the heater and the “Heater Installation Standards” in Section 7 of the Thermo King TriPac Installation and Standards Guide (TK 56498). **THESE STANDARDS MUST BE FOLLOWED!**

Heater Location

The location for mounting the heater will vary depending on the type of tractor. Typically, the heater is mounted inside the sleeper, under the bunk in a storage compartment.

DRILLING HOLE IN FLOOR

Special Tools Required
Drill Motor
Utility Knife
Center Punch
4-1/4” dia. Hole Saw
Fiberglass Cloth and Resin Kit (if required)

1. Position the heater’s metal mounting plate onto the floor mat.
2. Use a utility knife to cut the floor mat around the outside edges of the plate and then remove mat to access the bare floor.
3. With the mounting plate in position, center punch the four outer holes then remove the mounting plate and mark an “X” connecting the four center punched outer holes.
4. Center punch the center of the “X” and drill a 4-1/4” hole with a hole saw.

Figure 12. Marking and cutting the hole.

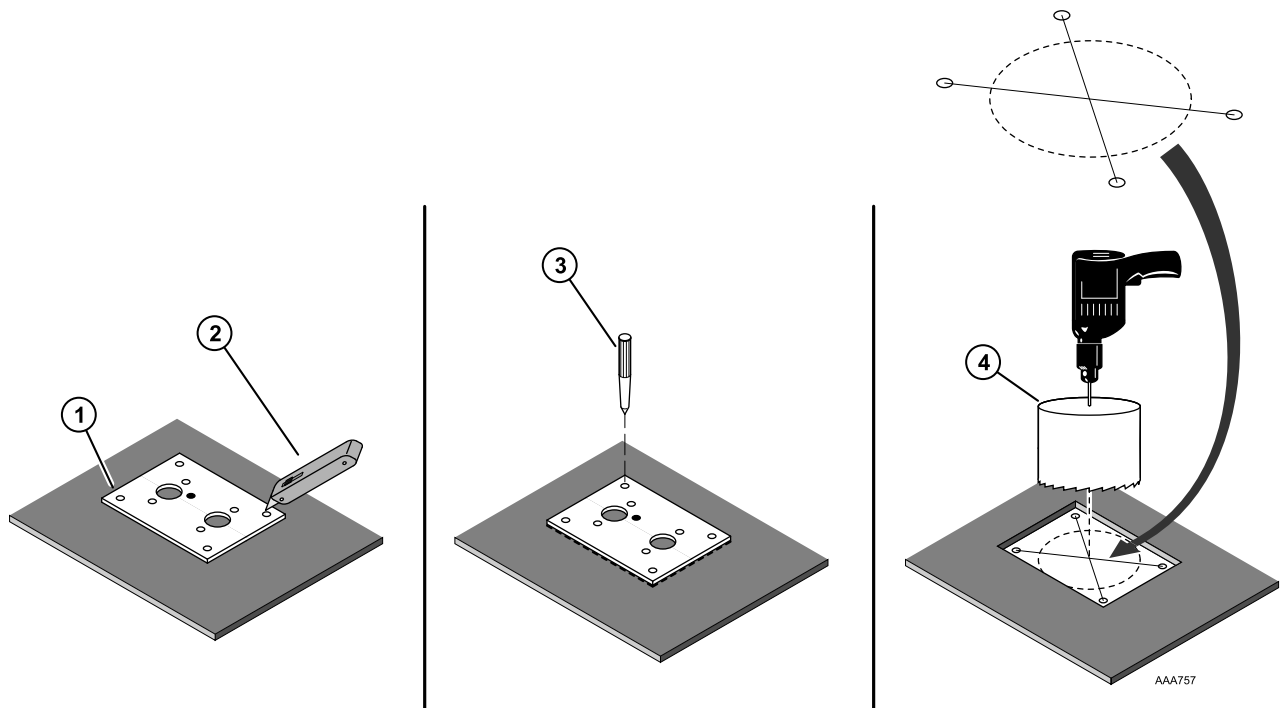

Heater Subassembly and Installation

Turn the heater upside down and attach the following components:

1. Snap the air outlet hood onto the end of the heater.
2. Place the mounting plate onto the heater studs. Mounting hardware will be installed later.
3. Attach the short rubber hose and clamps onto the fuel inlet connection located at the base of the heater.
4. Insert the plastic fuel line all the way into the rubber hose until it bottoms out to prevent air gaps. Tighten both hose clamps securely.
5. Attach the **exhaust hose** and **metal clamp** onto the fitting located under the **OUTLET** end of the heater. Turn metal clamp to the center and tighten securely.
6. Insert the plastic **air intake** tube through the beveled opening of the small plastic mounting plate. Install the plastic plate and tube onto studs located under the **INLET** end of the heater.
7. Install lock washers and nuts onto each of the mounting studs and tighten hardware securely.
8. Install gasket to mounting plate.
9. The heater has two service data nameplates. Remove one and reinstall it onto the top of the heater so that it is visible when the heater is installed.
10. Position the heater over the access hole with intake and exhaust hose and fuel line exiting the tractor. Attach the heater to the floor with TEK screws and tighten securely.

Note: Tighten TEK screws sufficiently to ensure a positive seal between mounting plate and mounting surface. Do not over tighten!

Figure 13. Heater subassembly and installation details shown.

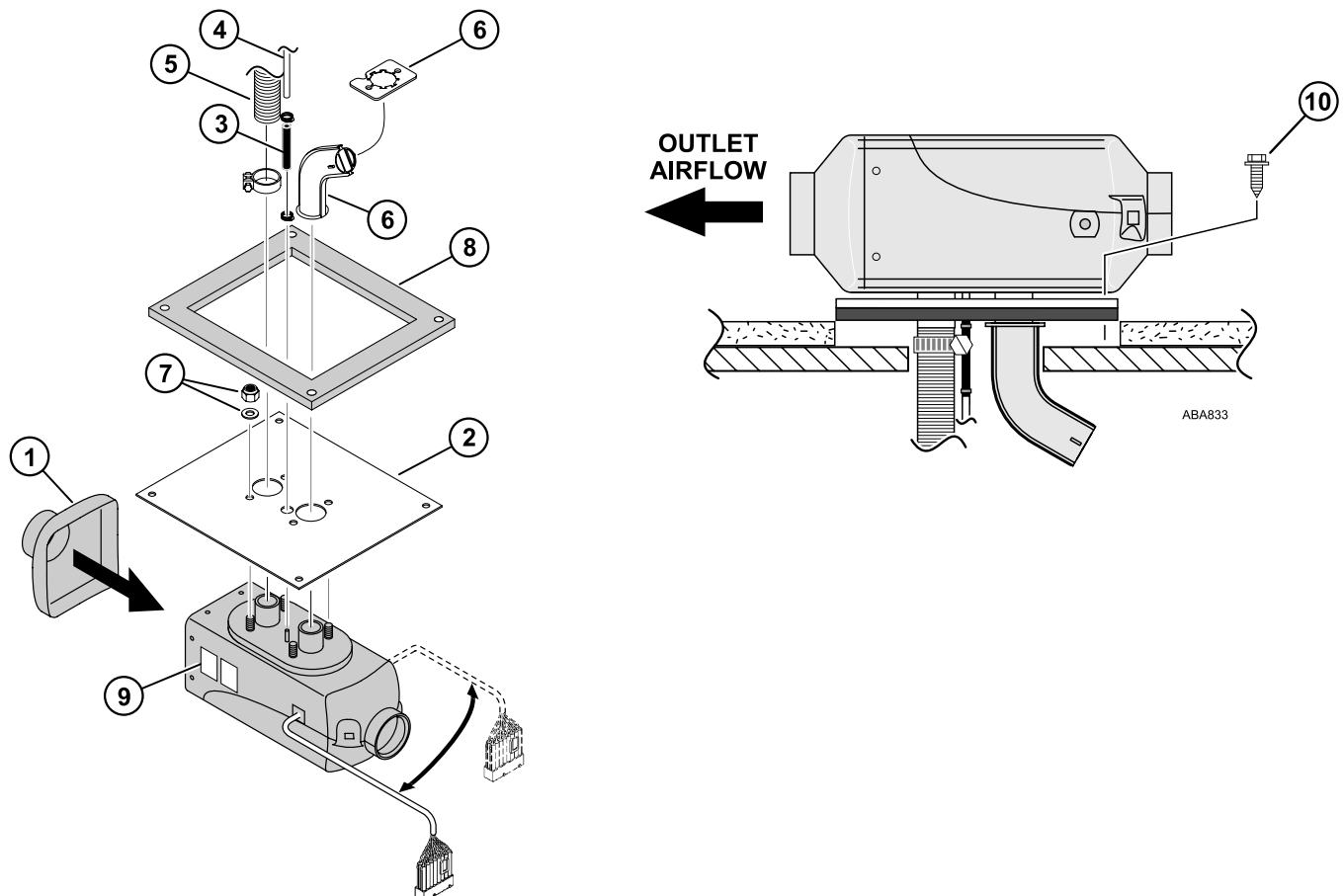

Exhaust and Combustion Air Intake Installation

INSTALLATION PROCEDURES

1. Route **exhaust hose** to an open area to rear or side of the truck or positioned slightly downwards to help drain off condensation and secure with clamps.
 - a. Drill a 1/8" hole in exhaust hose if necessary to allow for water drainage.
 - b. Exhaust hose can be shortened to a minimum of 8" if required.
2. Attach **metal** end cap to exhaust hose
3. Position **air intake tube** facing towards the rear of the tractor where it can pick up clean, fresh, moisture free air.
4. From underneath the sleeper:
 - a. Apply silicone sealant around **ONLY** the four heater mounting screws.
 - b. **DO NOT** apply any sealant around the access hole!

Figure 14. Exhaust and combustion air intake installation details shown.

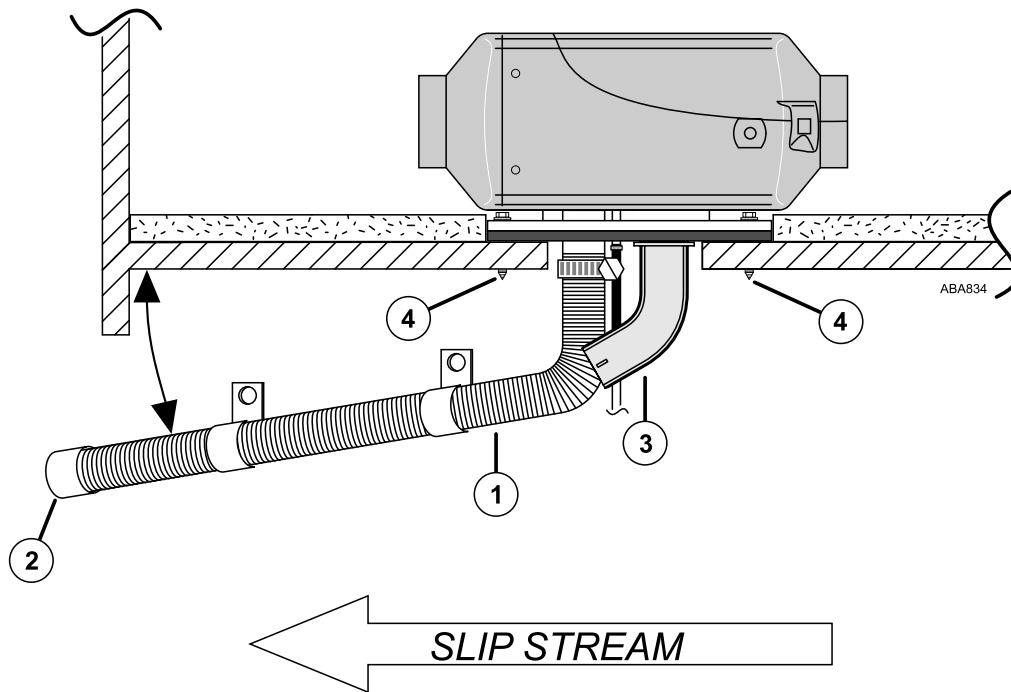

Return and Discharge Ducts and Vents Installation

The heater is equipped with a **Return Inlet** and **Discharge Outlet** for attaching the flexible heater duct hoses.

- **Return Inlet** must be provided to return air to the heater for best heating efficiency. It is typically mounted at the base of the bunk directly *opposite* the discharge outlet vent.
- **Discharge Outlet** should be located at floor level to provide maximum heating comfort in the sleeper. It is typically installed at the base of the bunk on one end.
- All heater ducts should be installed and routed with smooth bends and no kinks to provide maximum airflow.

INSTALLATION PROCEDURES

Special Tools Required
Drill Motor
2-1/2" Hole Saw (for installing discharge return air vents)
3" dia. Hole Saw (for routing ducts through compartment walls if required)

DISCHARGE AIR VENT

1. Find an appropriate location for the floor level discharge air vent and drill a **2-1/2"** hole using the correct hole saw.
 - a. Unsnap rotating outer louver assembly from mounting base.
 - b. Install base into 2-1/2" hole and secure with supplied screws
 - c. Reinstall rotating outer louver assembly back into mounting base ring. Verify that it rotates freely.
2. Attach one end of the heater duct to the discharge outlet hood on the heater and secure with supplied clamp.
3. Route the heater duct to the floor level discharge air vent, cut as needed, attach to the end of the plastic louver vent and secure with supplied hose clamp.

RETURN AIR DUCT

4. If a return air duct is not used, the protective grille must be installed onto heater inlet.
5. Find an appropriate location for floor level return air grille and drill a **2-1/2"** hole using correct hole saw.
 - a. Install return air grille into 2-1/2" hole and secure with supplied screws
6. Attach one end of return air duct to air inlet hood on heater and secure with supplied clamp.
 - a. Route return air duct to return air grille, cut as needed, attach to end of plastic louver vent and secure with supplied hose clamp.

Figure 15. Typical installation of discharge and return air ducts and vents shown.

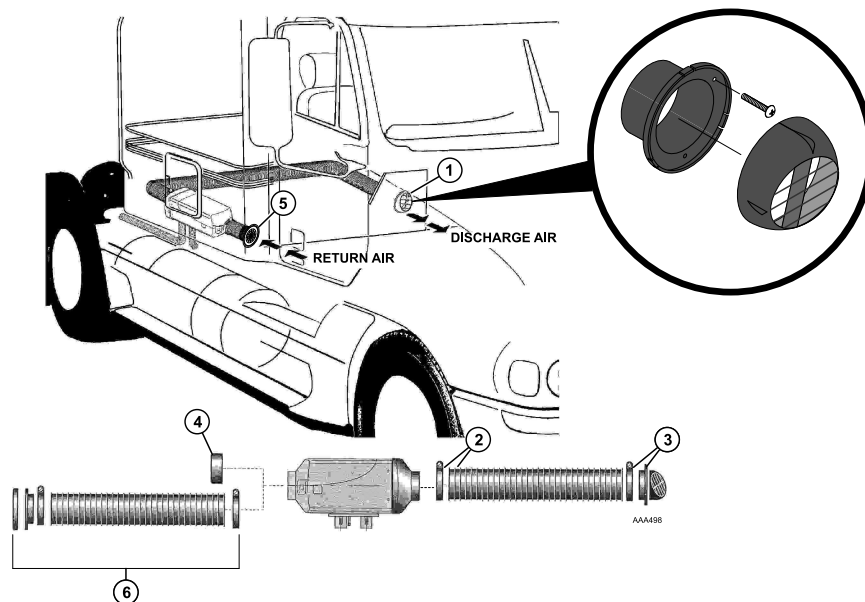

A/C Duct Installation

Important: Maximum cooling is obtained when the evaporator air discharge ducts and vents are installed and routed correctly in the bunk area. Proper air distribution from the A/C system provides maximum driver comfort. See “Evaporator Air Discharge Ducts and Vents Installation Standards” in Section 6 of the Thermo King TriPac Installation and Standards Guide (TK 56498). **THESE STANDARDS MUST BE FOLLOWED!**

Discharge Air Outlet Options

The evaporator has four discharge air outlets (two on each side of the evaporator) to choose from. Two outlets must be used to provide maximum air conditioning performance and driver comfort. Choose the best two discharge outlet option for you installation. Block off plates are included that allow these two options:

OPTION 1: having two *roadside* air ducts.

OPTION 2: having two *curbside* air ducts.

An optional block off kit is also available that allows a third option:

OPTION 3: having one *roadside* and one *curbside* air duct located either on the top or the bottom of the evaporator.

Figure 16. Discharge Air Outlets shown.

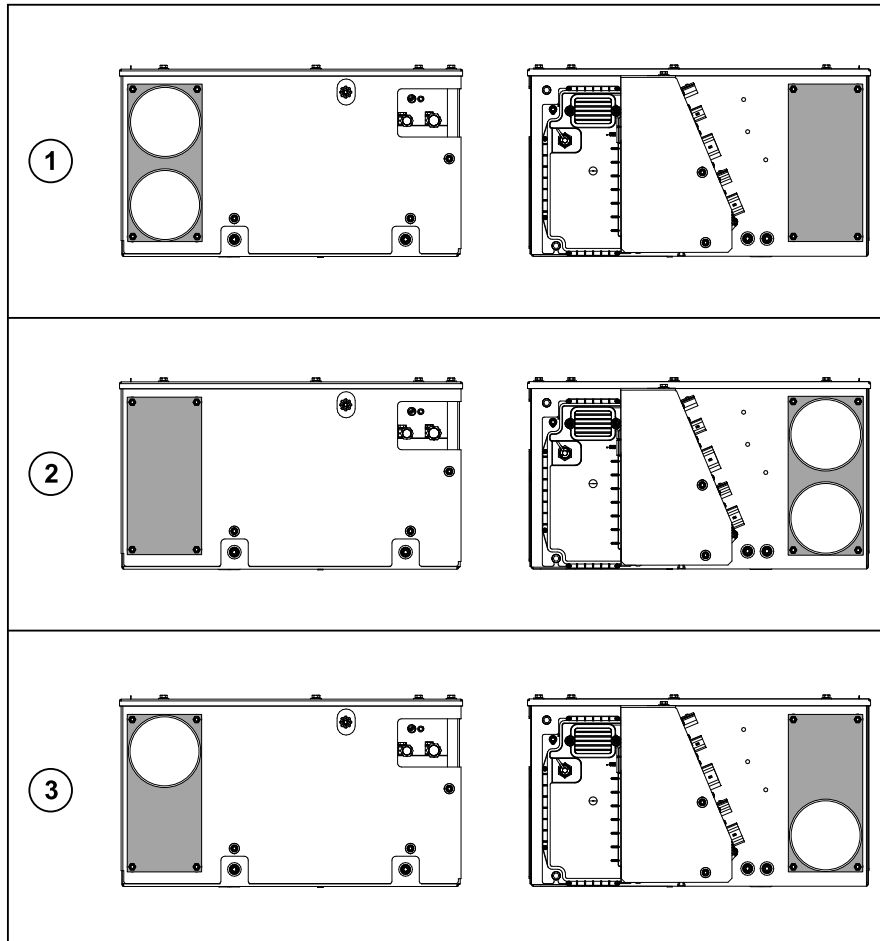

RCS696

Discharge Air Duct Installation

Note: It is important that the flexible air discharge air ducts are installed and routed properly for maximum air conditioning performance. These important air discharge duct installation points must be followed:

- Air ducts must be attached to two of the discharge air outlets and routed to the location chosen in your particular sleeper.
- Air ducts must be secured to the evaporator with the hose adapters and supplied hose clamps.
- Air duct lengths must always be kept as short as possible for maximum airflow.
- Air ducts must be installed and routed with smooth bends and no kinks for maximum airflow.
- Stretch hose first and then cut off excess.

Discharge Air Vent Installation

Note: Discharge air vents located too close to the air intake grille can cause short cycling of the A/C system. These important air discharge vent installation points must be followed:

- Discharge air hoses must be secured to hose adapters with supplied metal worm clamps.
- Supplied plastic air vents must then be installed to provide maximum air circulation in the sleeper.
- It is recommended the air vents be located on each side of the sleeper to provide maximum air conditioning performance and driver comfort.

Suggested locations of the air vents:

- a. MEDIUM (above lower bunk level)
- b. HIGH (above upper bunk level)
- c. *OEM Vents (when connected into to OEM HVAC ducts).
 *IMPORTANT: The back flow damper kit must be installed when connecting TriPac Envidia A/C discharge hose into OEM ducts.

Special Tools Required
Drill Motor
4-1/4" Hole Saw (for installing plastic A/C louver vents and routing ducts through compartment walls.

INSTALLATION PROCEDURES

1. Install the hose adapters into each air discharge outlet plate.
2. Find appropriate locations for the A/C vent(s) inside the sleeper and drill 4-1/4" diameter hole(s).
3. Attach the flexible air duct onto hose adapter(s) and secure with a supplied hose clamp.
4. Route the flexible air duct through the A/C vent hole. Cut excess duct as needed.
5. Unsnap rotating outer louver assembly from the mounting base.
6. Attach to flexible air duct to the end of the hose adapter with band wrap.
7. Push the hose adapter back into 4-1/4" mounting hole and secure with supplied screws.
8. Reinstall rotating outer louver assembly back into the hose adapter and verify that it rotates freely.
9. Verify flexible ducts are installed and routed with smooth bends and no kinks to provide maximum airflow.
10. Secure flexible ducts with large band wraps to prevent excess movement

Figure 17. Typical A/C Duct locations shown.

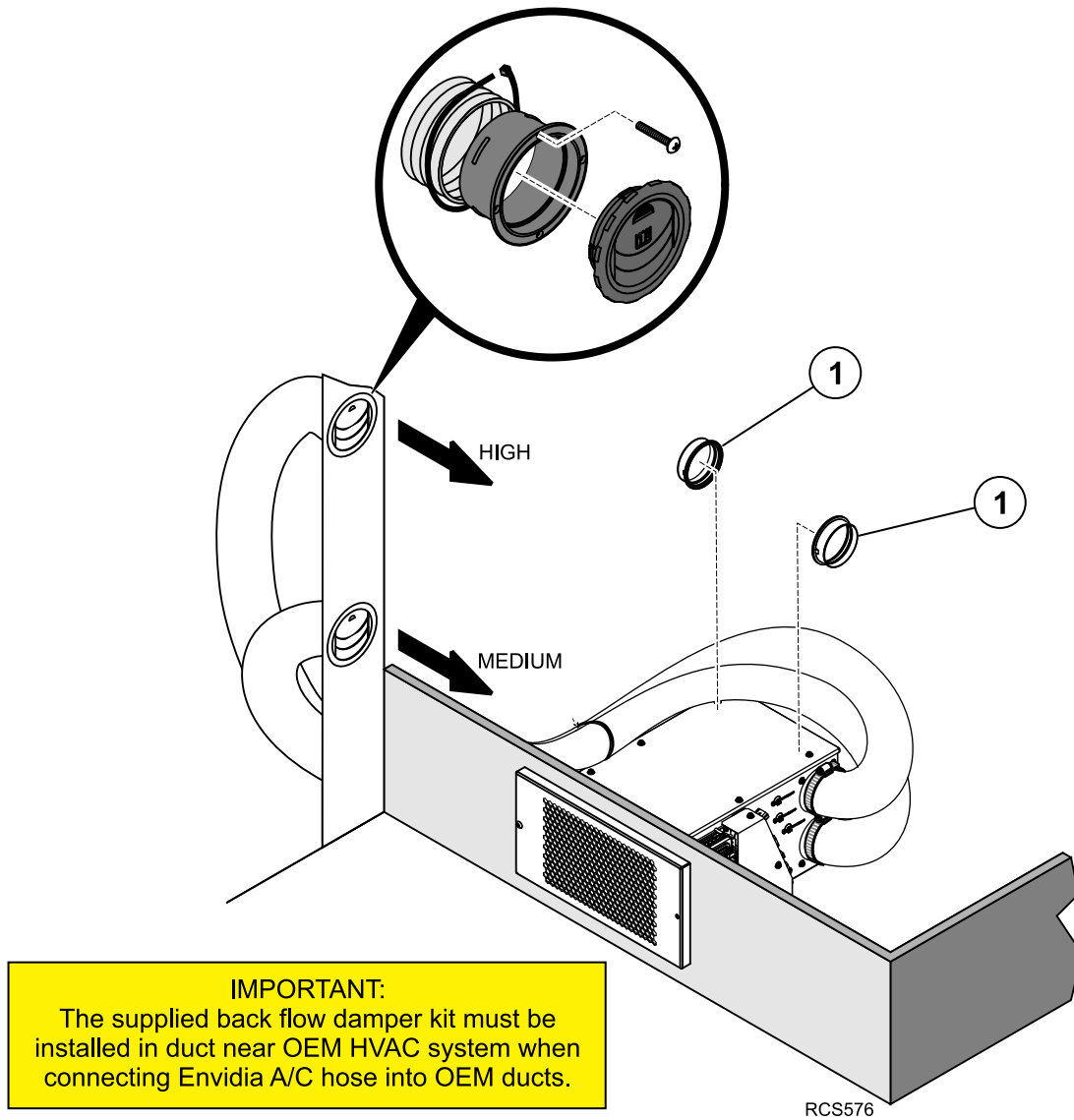

Backflow Damper Installation

Important: The back flow damper must be installed when connecting the evaporator A/C discharge hose into OEM ducts. Reduced system performance will result if damper is not installed. See "Backflow Damper Installation Standards" in Section 6 of the Thermo King TriPac Installation and Standards Guide (TK 56498). **THESE STANDARDS MUST BE FOLLOWED!**

The back flow damper kit includes detailed installation instructions. It is the installer's responsibility to install the backflow damper correctly. Some fabrication is necessary.

Figure 18. Discharge airflow shown with and without a backflow damper.

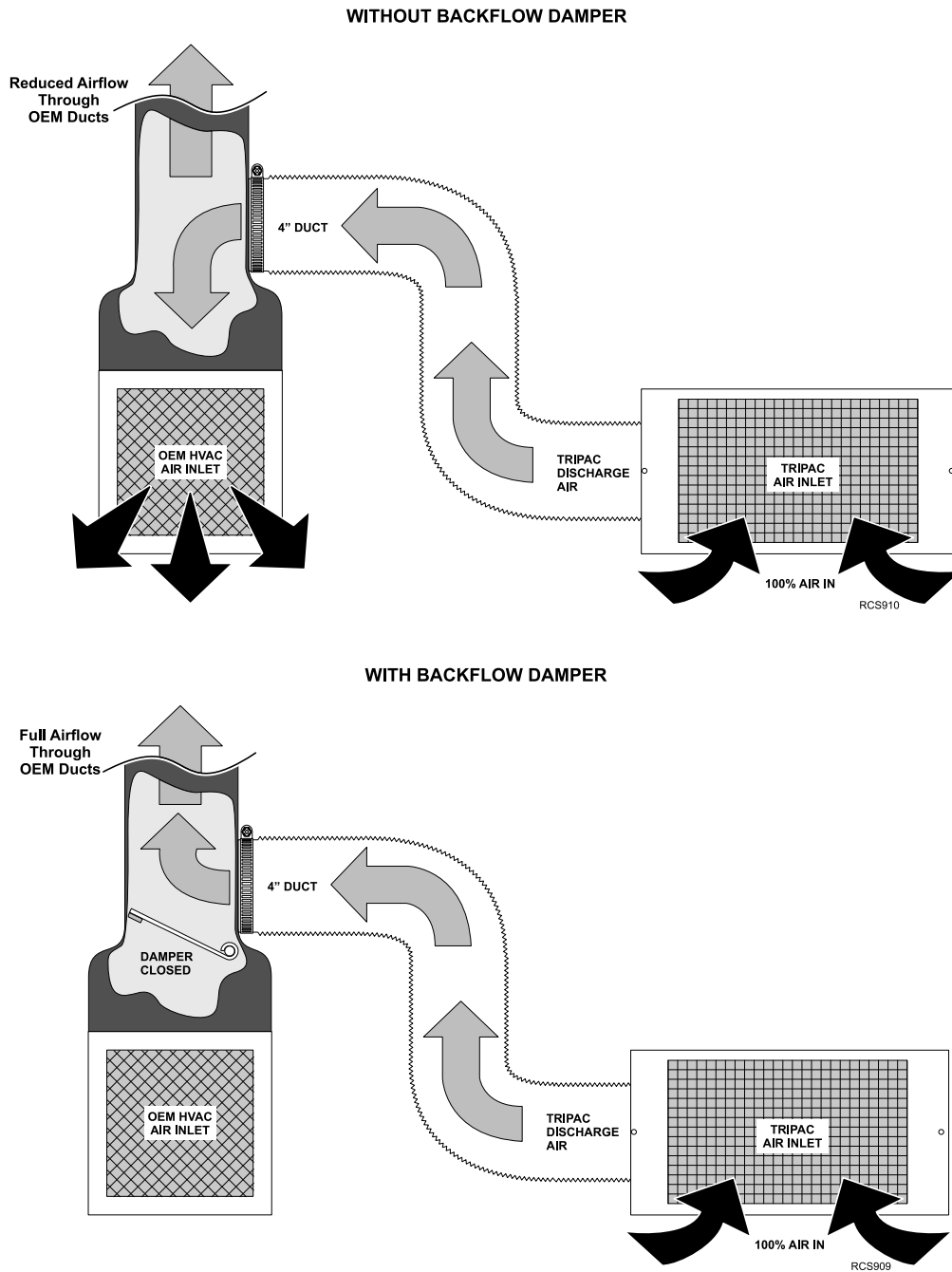

Battery Box Harness Installation

Important: See “Electrical Standards” in Section 10 of the Thermo King TriPac Installation Standards Guide (TK56498).
THESE STANDARDS MUST BE FOLLOWED!

Important: Before making any electrical connections, confirm the battery cables in the TriPac battery box and truck battery box are not connected to the batteries.

Note: Excessive harness length should be doubled up and secured with band wraps. **DO NOT CUT THE HARNESS!**

Note: Always check the male pins for straightness before attempting to mate connectors. If any resistance is felt when mating the connector: recheck the male pin alignment. Exercise care when mating the connections to circuit boards.

INSTALLATION PROCEDURES

1. **From the TriPac Battery Box** route the Communication Harness and the two white (8 AWG) power wires through the floor access hole to the Evaporator/Control Box connector panel.
2. Attach the 12-pin communication harness connector to **(J8)** on connector panel.
3. Remove cover plate from connector panel. This will be reinstalled later.
4. Route #2 Power wire through upper grommeted hole in connector panel.
 - a. Cut cable to length and terminate with ¼” terminal lug.
 - b. Install RED battery boot over terminal lug.
 - c. Attach terminal lug onto (+2) stud and tighten nut to 18 in-lbs. (2.0 Nm).
 - d. Secure cable with the cable ties located on the Evaporator/Control Box housing.
5. Route CH-01 Ground wire through lower grommeted hole in connector panel.
 - a. Cut cable to length and terminate with ¼” terminal lug.
 - b. Attach terminal lug onto **(CH)** stud and tighten nut to 18 in-lbs. (2.0 Nm).
 - c. Secure cable with the cable ties located on the Evaporator/Control Box housing.

Important: Make sure the two terminal lugs are not touching each other!
6. Reinstall cover plate and tighten hardware securely.
7. **From the TriPac Battery Box** route the RED and BLACK (1/0 AWG) battery cables from the TriPac battery box to the truck battery box. **DO NOT CONNECT BATTERY CABLES AT THIS TIME.**

Figure 19. Cable Connections Shown.

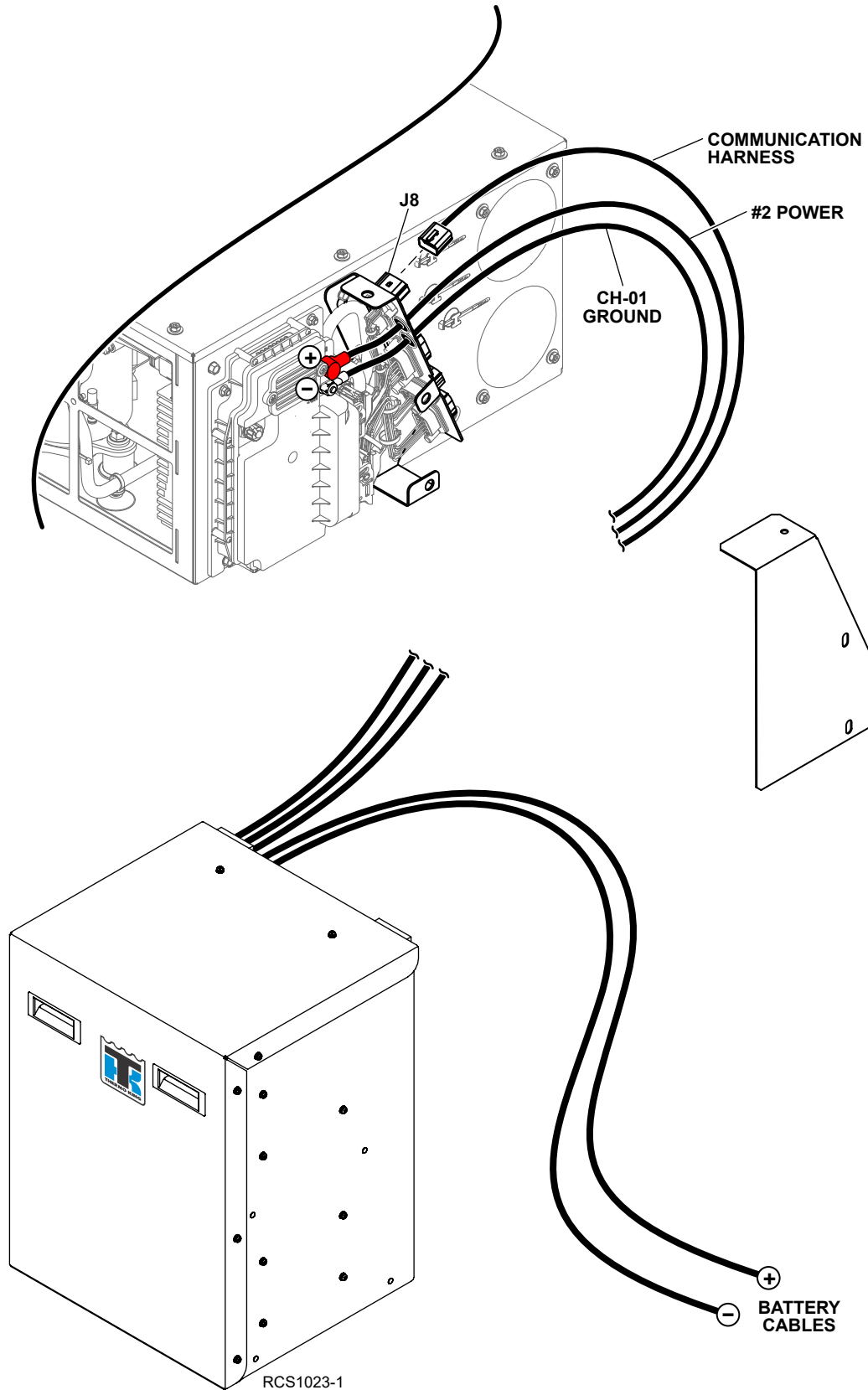

Battery Box Harness Installation

8. From the Evaporator/Control Box route the RED and BLACK (4 AWG) power cables through the floor access hole down to the Envidia Battery Box. These cables are pre-connected to the Compressor Drive Module inside the Evaporator/Control Box.
9. Route positive cable (RED) through the current sensor hole in the back of the battery box to the F10 fuse (150 amp) in the holder.
 - a. Cut cable to length and terminate with terminal lug with a 1/4" hole.
 - b. Add the white #2 power wire (8 AWG) to the split loom of positive cable (RED) to combine them before entry into the current sensor hole (as shown in image below). Secure with zip ties, as necessary.
 - c. Attach terminal lug to F10 fuse holder terminal and tighten nut to 120 in-lb (13.5 Nm). Route negative (BLACK) cable through the upper hole in the back of the battery box to the chassis ground stud.
10. Route negative (BLACK) cable through the upper hole in the back of the battery box to the chassis ground stud.
 - a. Cut cable to length and install terminal with 3/8" hole.
11. Connect to chassis ground stud and tighten nut securely.
12. Secure to existing cables.

Figure 20. Cable connections shown.

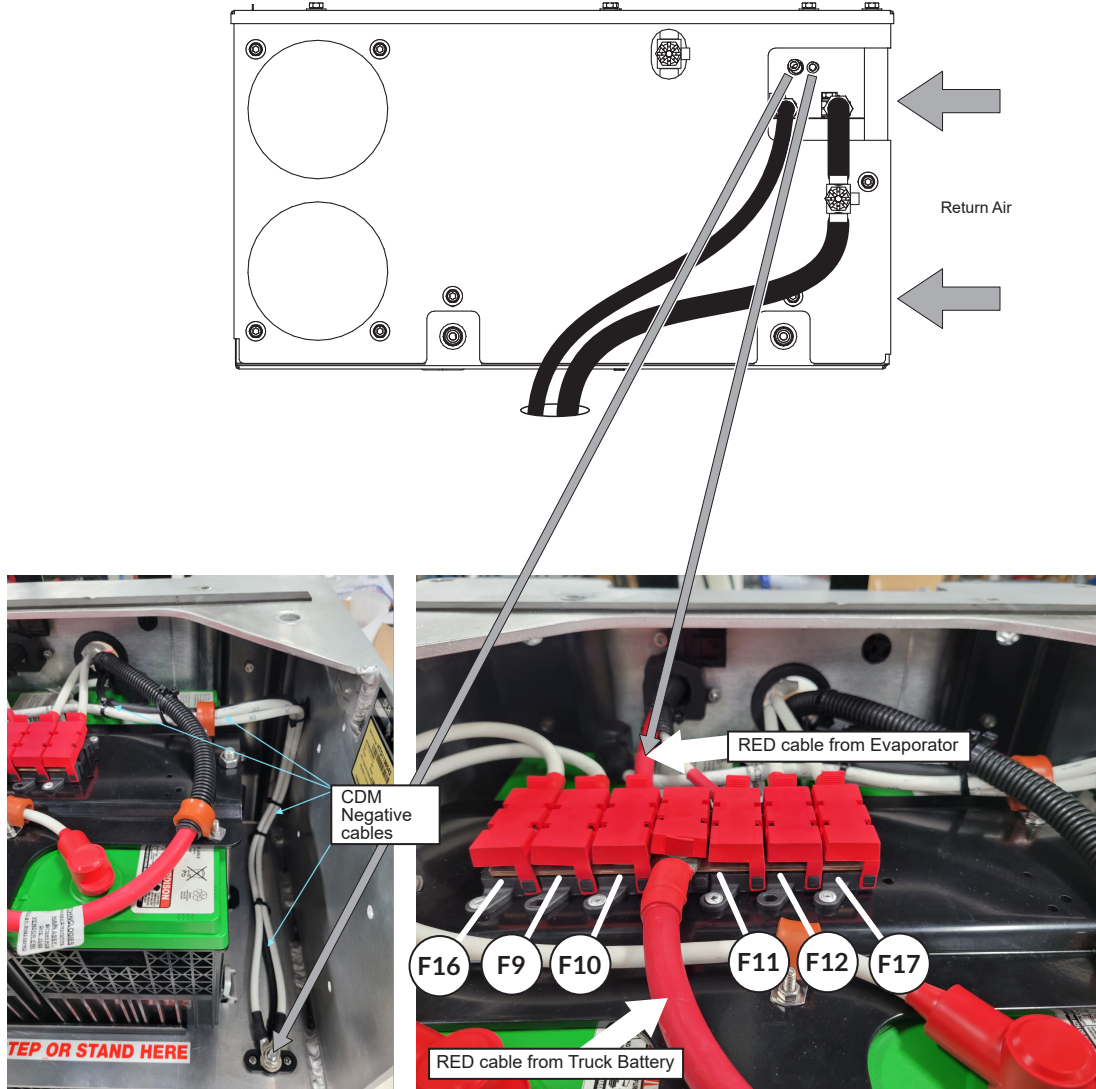

RCS581-2

Figure 21. Evaporator/Control Box to Battery Box Connections shown.

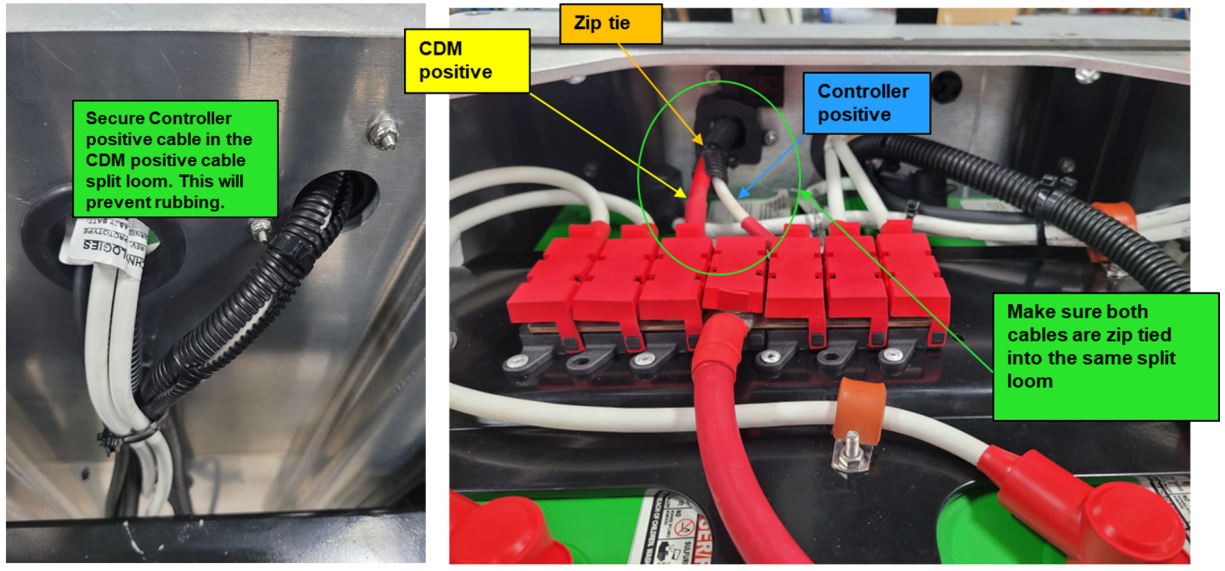

RCS2203

Condenser Fan and Sensor Harness Installation

Important: See “Electrical Standards” in Section 10 of the Thermo King TriPac Installation Standards Guide (TK 56498).
THESE STANDARDS MUST BE FOLLOWED!

Important: Before making any electrical connections, confirm the battery cables in the TriPac battery box and truck battery box are not connected to the batteries.

Note: Excessive harness length should be doubled up and secured with band wraps. **DO NOT CUT THE WIRE HARNESS!**

Note: Always check the male pins for straightness before attempting to mate connectors. If any resistance is felt when mating the connector: recheck the male pin alignment. Exercise care when mating the connections to circuit boards.

Evaporator/Control Box

1. Locate Condenser Fan and Sensor Harness supplied loose in installation kit.
2. Attach 6-pin connector from the Sensor Harness to the Condenser (J6) connector located on Connector Panel outside Evaporator/Control Box.
3. Route the harness down through the 2” access hole in the truck floor and out to the condenser fan.

Condenser Assembly

4. Connect the 4-pin connector to the matting connector from the condenser fan.
5. Attach the Ambient Air Sensor to the *inside* of the receiver drier bracket with the supplied clamp and mounting hardware.

Note: Always install the sensor to the inside of the drier bracket for best temperature readings and to protect it from damage.

6. Secure all harness adequately with insulated clamps or band wraps.

Figure 22. Condenser Harness and Sensor Harness Connections Shown.

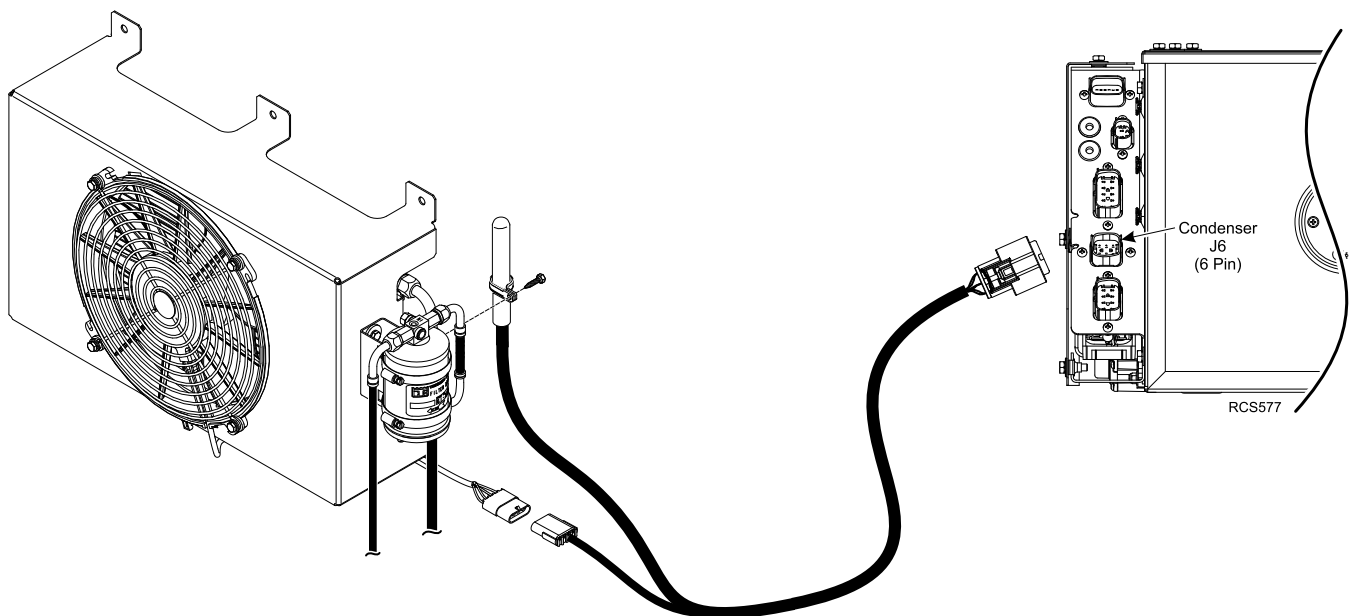

Ignition Switch and Harness Installation

Important: See “Electrical Standards” in Section 10 of the Thermo King TriPac Installation Standards Guide (TK 56498). **THESE STANDARDS MUST BE FOLLOWED!**

Note: The Ignition Sense harness wire must be connected to the ON or RUN position of the truck’s ignition system. This will prevent the HVAC system from operating and allow battery charging when the truck’s engine is running.

INSTALLATION PROCEDURES

1. Locate the **Ignition Sense** harness supplied loose in the installation kit and route the harness towards the truck’s ignition switch.
2. Attach the end with the diode and fuse to the ON or RUN position of the truck’s ignition switch.
3. Secure the harness adequately with band wraps.

Note: On some truck models the ignition switch acts only as a selector device connected to an ignition module. There may not be system power available at the switch. The TriPac Envidia system may not function correctly. In this case locate the truck ignition module and connect to the ON or RUN output.

Figure 23. Ignition Switch Harness Connections Shown.

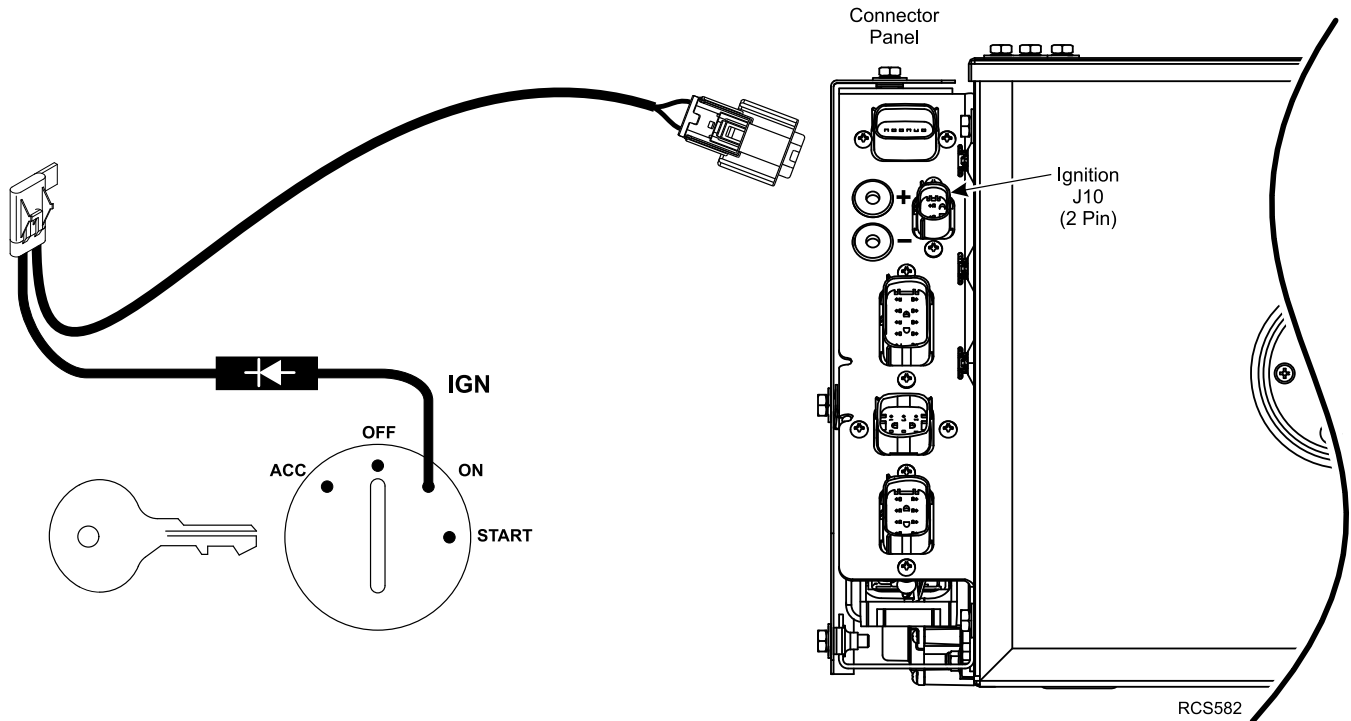

HMI Installation

Important: See “HMI Controller Installation Standards” in Section 10 of the Thermo King TriPac Installation Standards Guide (TK 56498). **THESE STANDARDS MUST BE FOLLOWED!**

Special Tools Required
Level
Drill Motor
Drill Bits

INSTALLATION PROCEDURES

1. Locate HMI Controller Harness supplied loose in installation kit and attach **BLACK** 8-pin connector to HMI (**J7**) connector on Evaporator/Control Box connector panel.
2. Route harness behind interior walls (if applicable) to location chosen to install the HMI controller.
3. Unsnap rear mounting base from controller and route harness connector through access hole.
 - a. Position and level mounting base and install securely.
4. Push **WHITE** connector firmly into rear of controller.
5. Snap controller back onto mounting base.
6. Secure harness adequately.
7. Two operator’s nameplates are supplied loose in installation kit.
 - a. Attach smaller nameplate on top of HMI as shown.
 - b. Place the larger nameplate and the Driver’s Card into the envelope provided in the installation kit. The large nameplate can be installed in a location chosen by driver.
 - c. Include the Espar Heater CD (if applicable).

Figure 24. HMI Harness Connections and Operator’s Nameplates Shown.

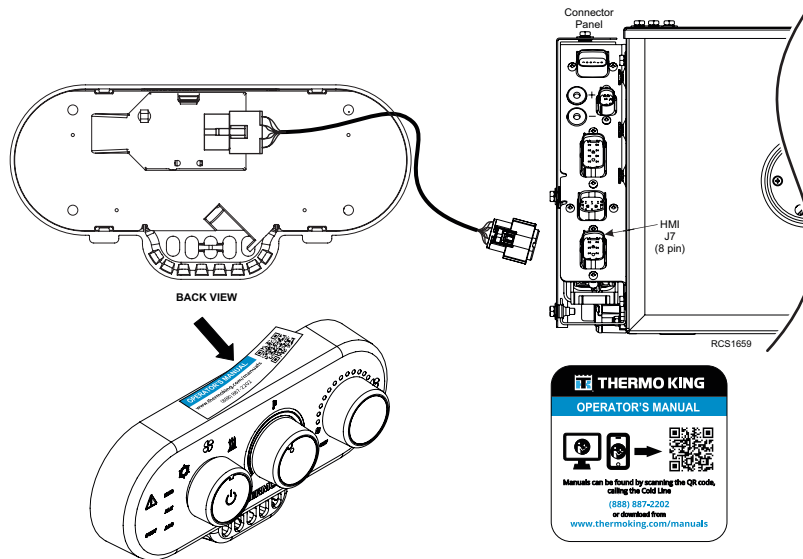

USB Service Communication Cable Installation

The USB Service Communication Cable allows technicians to easily access the communication application.

INSTALLATION PROCEDURES

1. Remove the cover over the USB Communication Port located on the Base Controller.
2. Plug the USB Mini-B connector into the communication port.
3. Route the cable to a protected area that is accessible without raising the bunk. Recommend inside truck tool box door.
4. Secure communication cable to other harnesses or cab structure.

Figure 25. USB Cable Connection Shown.



RCS584

D2/D4 Heater Harness Installation (Heat Option)

Important: See “Electrical Standards” in Section 10 of the Thermo King TriPac Installation Standards Guide (TK 56498).
THESE PROCEDURES MUST BE FOLLOWED!

INSTALLATION PROCEDURES

1. Locate the Heater Harness supplied loose in the installation kit. Remove the two small plastic bags attached to the harness containing the fuel pump electrical connector components and the in-line fuse assembly and retain these for installation later.
2. Connect the **14-pin** connector (with the locking tab) to the mating connector on the heater.
 - a. Use a large bladed screwdriver to pull the locking tab out (**to unlock**) from the connector body.
 - b. Connect the two connectors together.
 - c. Push locking tab back in (**to lock**) the connector body.
3. Connect the 10-pin connector to the Heater (**J9**) connector on the Evaporator/Control Box connector panel.
4. Route the fuel pump harness out of the sleeper through the 2” access hole. It will be assembled and connected to the fuel pump in a later step.

Note: The Diagnostic Connector near the heater is only used for diagnostic purposes.

Figure 26. Heater Harness to Evaporator/Control Box Connection Shown.

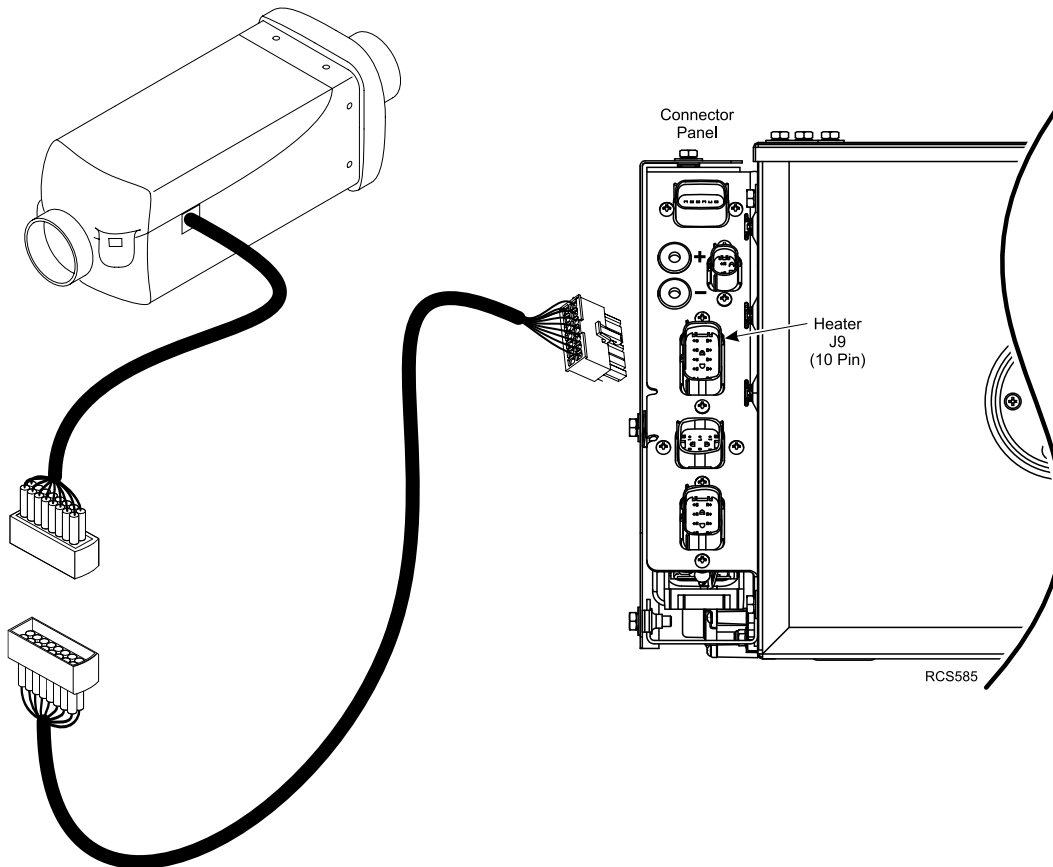

Heater Fuel Pickup Tube Installation (Heat Option)

Direct Tank Installation – with OEM Fuel Tank Fittings

Important: See “Fuel Pickup Tube Installation Standards” in Section 7 of the Thermo King TriPac Installation Standards Guide (TK 56498). **THESE STANDARDS MUST BE FOLLOWED!**

Fuel tanks with auxiliary fuel connections or 1/4" NPT connections factory installed eliminate the need to drill into the fuel tank to install the heater’s fuel pickup tube.

- **Tanks with OEM Fuel Connections** - Route and connect the heater’s fuel supply line to one of these fittings
- **Tanks with OEM 1/4" NPT Fitting** - See following installation instructions.

Special Tools Required
Tape Measure
Tubing Cutter

Important Installation Tips:

- Remove the protective cap from the end of the pickup tube prior to installation.
- Do not apply any type of sealant material to the fuel pickup tube assembly. Doing so will result in plugged fuel lines.

INSTALLATION PROCEDURES

Note: The tank mounted fuel pump bracket cannot be used on direct tank installations. The supplied remote mounted L-bracket must be used.

1. Remove the nut, washers and bushing assembly from the fuel pickup tube as shown. The nut, washers and bushing assembly will not be used.
2. Remove the 1/4" NPT fitting from fuel pickup tube and install it into the fuel tank’s 1/4" NPT fitting securely.
3. Measure the fuel tank diameter and cut the pickup tube 3” shorter.
4. Install the pickup tube with the ferrule nut into the tank.
 - a. Position the pickup tube as needed to facilitate fuel line connections and tighten ferrule nut securely.
5. Install the supplied warning nameplate onto the fuel tank in a visible area near the fuel cap.

Figure 27. Direct Tank Installation – with OEM Fuel Tank Fittings.

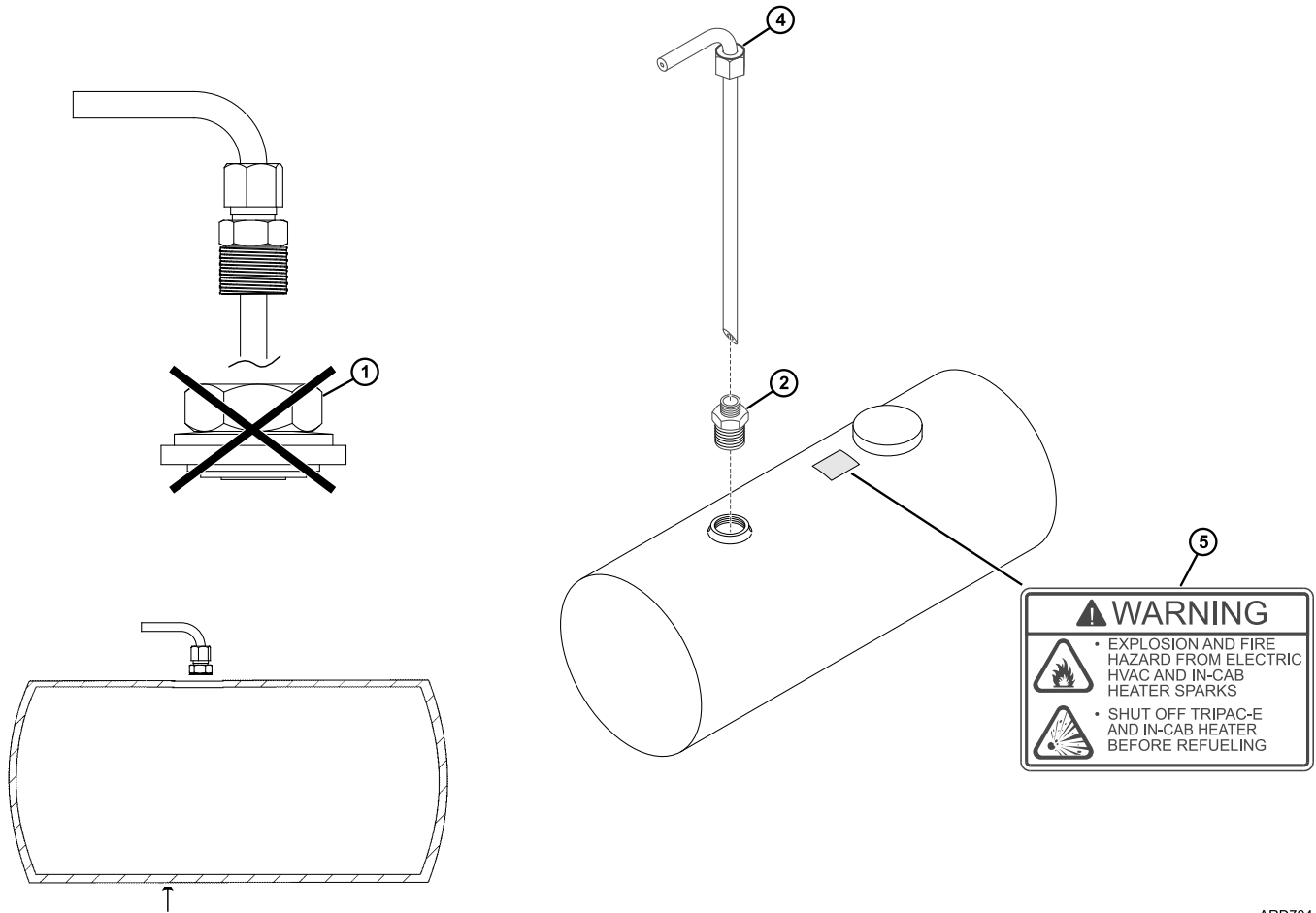

ARD704

Alternative Installation – Drilling Hole in Fuel Tank

Special Tools Required
Tape Measure
Drill Motor
¼" Drill Bit
1" Hole Saw
Tubing Cutter

IMPORTANT INSTALLATION TIPS

- Check for internal baffles inside the fuel tank BEFORE drilling any holes.
- Remove protective caps from ends of pickup tube prior to installation.
- Do not apply any type of sealant material to the fuel pickup tube assembly. Doing so will result in plugged fuel lines.
- The ferrule nut and 1/4" NPT fitting must be tightened securely into the bushing before installing the pickup tube into the tank. Failure to tighten the fittings will allow the bushing and washer assembly to slide down the pickup tube and drop into the fuel tank.

INSTALLATION PROCEDURES

1. Measure and mark the mounting holes on the fuel tank as shown.
2. Drill (2) 0.25" outer holes first followed by the 1.00" center hole.
 - a. Thoroughly clean and flush the tank to remove any chips.
3. Measure the fuel tank diameter and cut the pickup tube 3" shorter.
 - a. With the pickup tube positioned at the correct height, place a wrench on the flats of the bushing and tighten the 1/4" NPT fitting and the ferrule nut securely.

Important: The ferrule and 1/4" NPT Fitting must be tightened securely into the bushing before installing the pickup tube into the tank.
4. Remove the large nut, metal cupped washer and rubber washer from the bushing assembly.
 - a. Insert the fuel pickup tube (with the reinforcing washer) into the tank using the slot created by the two 0.25" holes.
 - b. Lift the pickup tube and bushing into position through the 1.00" hole.
 - c. Hold the pickup tube in place and reinstall the rubber washer, metal cupped washer, fuel pump bracket and large nut onto the bushing. Hand tighten the large nut.
 - d. Position the pickup tube as needed to facilitate fuel line connections.
 - e. Place a wrench on the flats of the bushing and tighten the large nut securely.
5. Install the supplied warning nameplate onto the fuel tank in a visible area near the fuel cap.



Figure 28. Fuel Pickup Tube Installation – Drilling Hole in Tank.

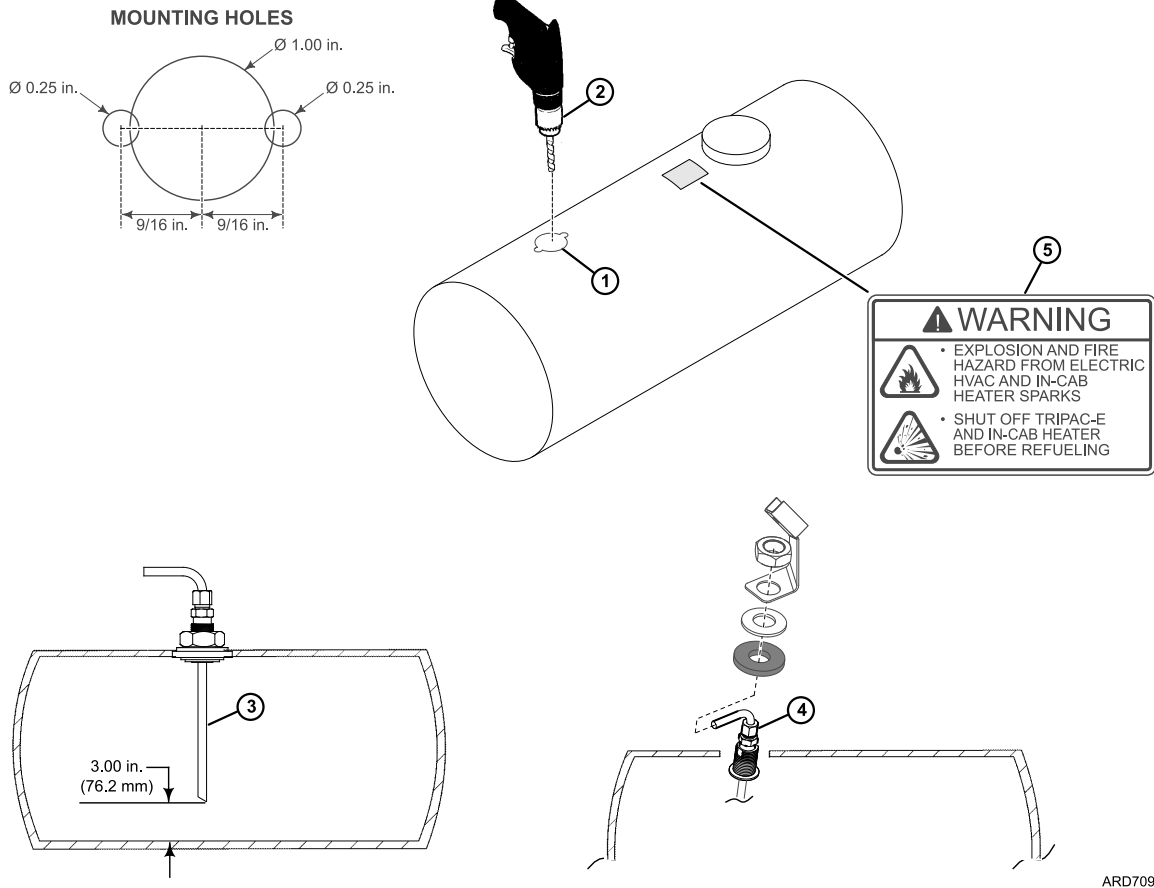

Fuel Pump and Fuel Line Installation (Heat Option)

Important: See “Heater Fuel Pump Installation Standards” and “Heater Fuel Line Installation Standards” in Section 7 of the Thermo King TriPac Installation Standards Guide (TK 56498). **THESE STANDARDS MUST BE FOLLOWED!**

Special Tools Required
Utility Knife
Hose Cutting Tool (204-677)

IMPORTANT INSTALLATION TIPS

- Fuel line must be installed correctly to prevent air bubbles (**See Detail A**).
- Fuel line from the pickup tube, to fuel pump, to heater must be routed at a continuous rise.
- Use only hose cutter or utility knife to cut plastic fuel lines. Do not use a wire cutter as this will pinch the plastic fuel line closed.

Tank Mounted Fuel Pump

1. Install fuel pump and rubber clamp onto tank mounted bracket securely.
2. Attach fuel line hose from fuel pick-up supply to **inlet** end of fuel pump and secure with supplied hose clamps.
3. Attach short rubber hose connection to **outlet** end of fuel pump and secure with supplied hose clamps.
4. Route plastic fuel line (installed earlier on heater) to fuel pump and cut to length. Insert fuel line into rubber hose connection until it butts up tight with fuel pump’s outlet pipe (**See Detail A**). Secure with supplied hose clamp.

Figure 29. Tank Mounted Fuel Pump Shown.

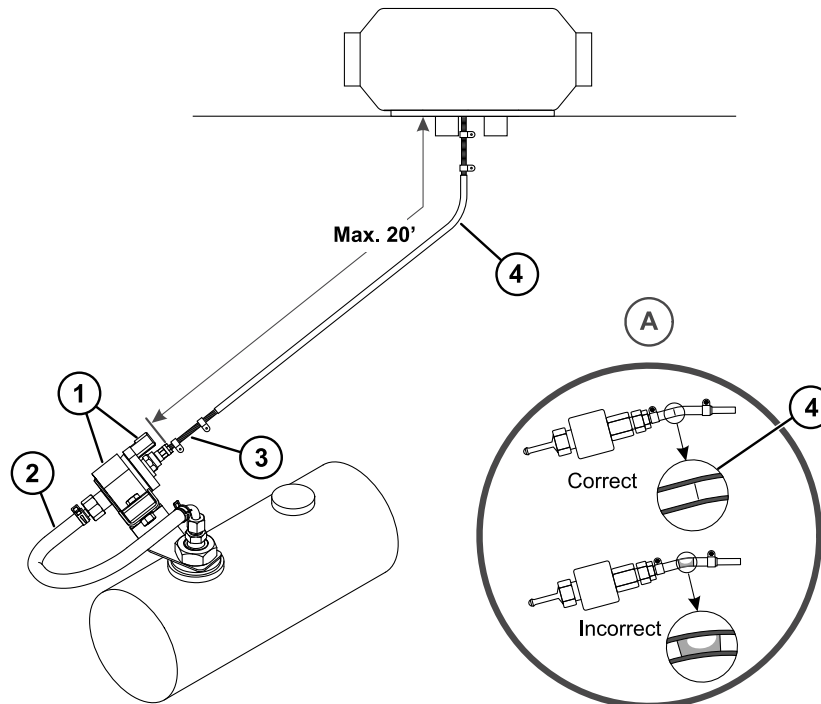

RCS1015

Remote Mounted Fuel Pump with L-Bracket

Choose a protected location under the cab close to the fuel pick-up tube and heater and install the supplied L-bracket securely with TEK screws.

1. Install the fuel pump into the rubber mounting clamp and then onto the L-bracket.
2. Position the fuel pump at a 15 to 35 degree angle with the outlet end facing up (outlet end has connector and smaller barb fitting) and tighten mounting hardware securely.
3. Attach the short rubber hose connection to the **outlet** end of the fuel pump and secure with supplied hose clamp.
4. Route the plastic fuel line (installed earlier on the heater) to the fuel pump and cut to length. Insert the fuel line into the rubber hose connection until it butts up tight with the fuel pump's outlet pipe. Secure with supplied hose clamp.
5. Attach fuel line from the fuel pick-up supply to the inlet end of the fuel pump and secure with supplied hose clamps.

Figure 30. Remote Mounted Fuel Pump with L-Bracket Shown.

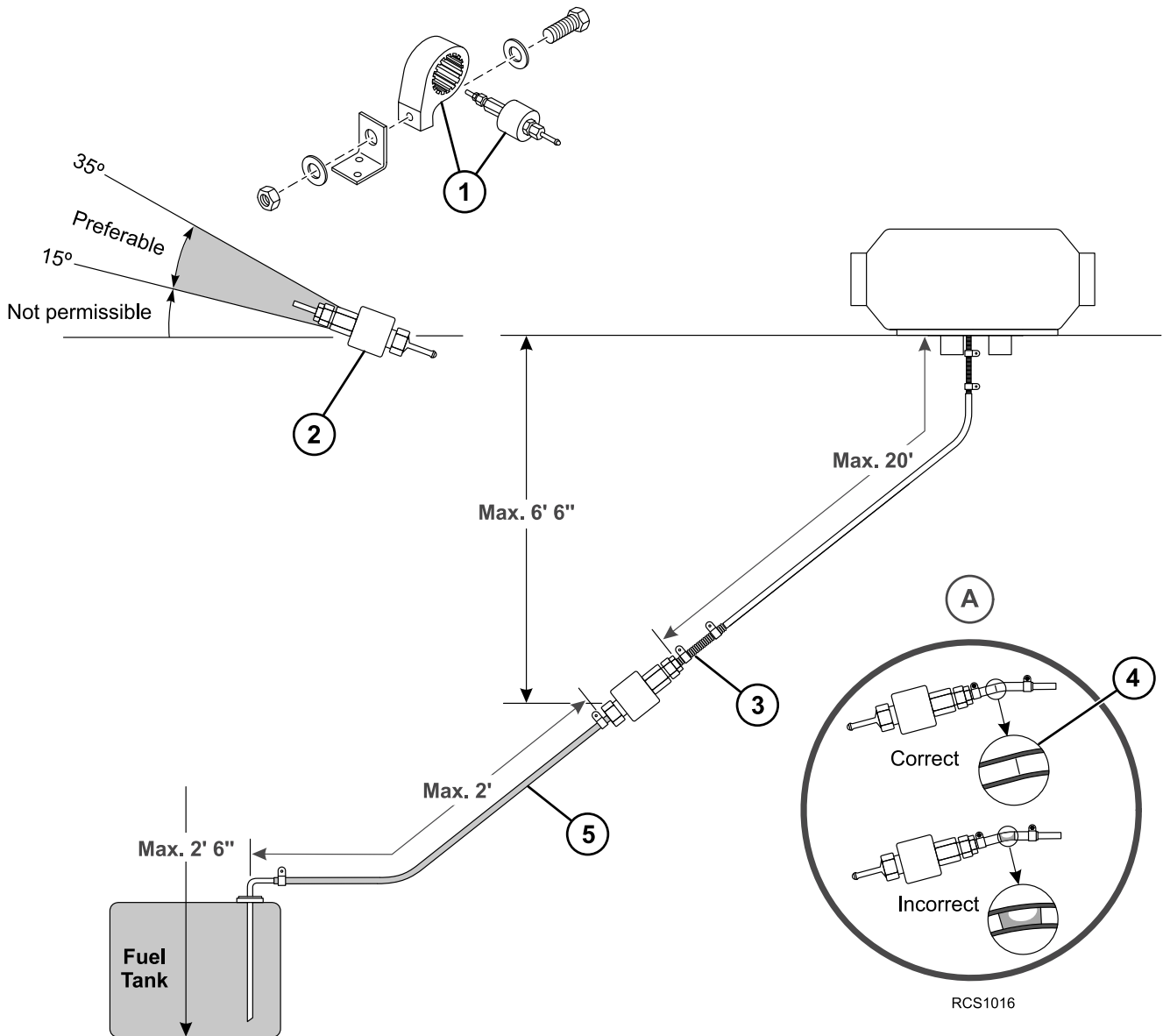

Heater Fuel Pump Connections (Heat Option)

Important: See “Heater Fuel Pump Connector” in Section 10 – Electrical Standards of the Thermo King TriPac Installation Standards Guide (TK 56498). **THESE STANDARDS MUST BE FOLLOWED!**

Important: To prevent the heater from starting unexpectedly, set all electrical controls to the OFF position **BEFORE** connecting wires to battery.

Tools Required
Wire Cutters
Terminal Crimping Tool

1. Route the heater fuel pump harness (installed earlier) to the heater fuel pump and cut the wires to the correct length.
 - a. Strip wire ends, slide on rubber sealing boots and attach pin terminals securely with crimping tool.
 - b. Insert pin terminals into connector body until they lock in place.

Note: The pump is not polarity sensitive. The wires can be installed in either location of the connector body.

 - c. Snap locking cover closed on connector body.
 - d. **DO NOT** connect the fuel pump harness to the fuel pump at this time. The fuel pump harness will be attached later after the fuel pump has been primed.

Figure 31. Heater Fuel Pump Connections Shown.

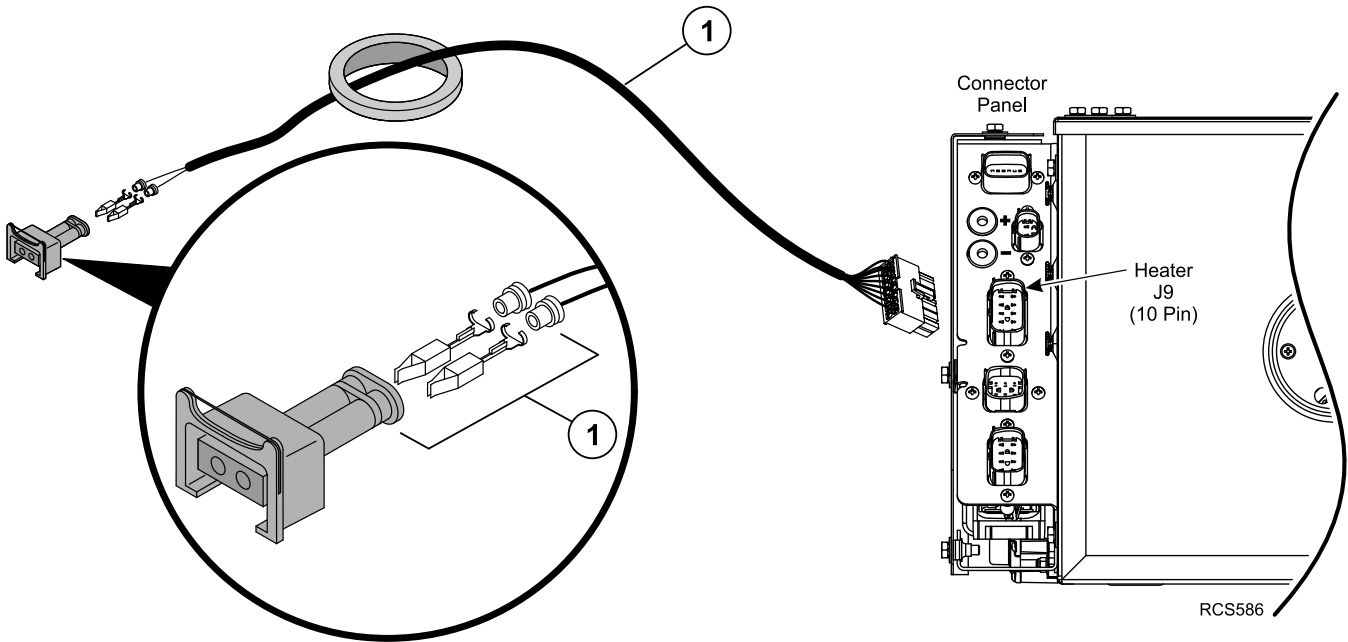

RCS586

Auxiliary AC Power Accessories (Option)

DC/AC Power Inverter Only

- Follow the installation instructions supplied with the Power Inverter.
- Connect tractor's batteries directly to inverter as shown.

Important: DO NOT connect auxiliary power accessories to the TriPac ENVIDIA batteries.

Figure 32. DC/AC Power Inverter Connections to Battery Shown.

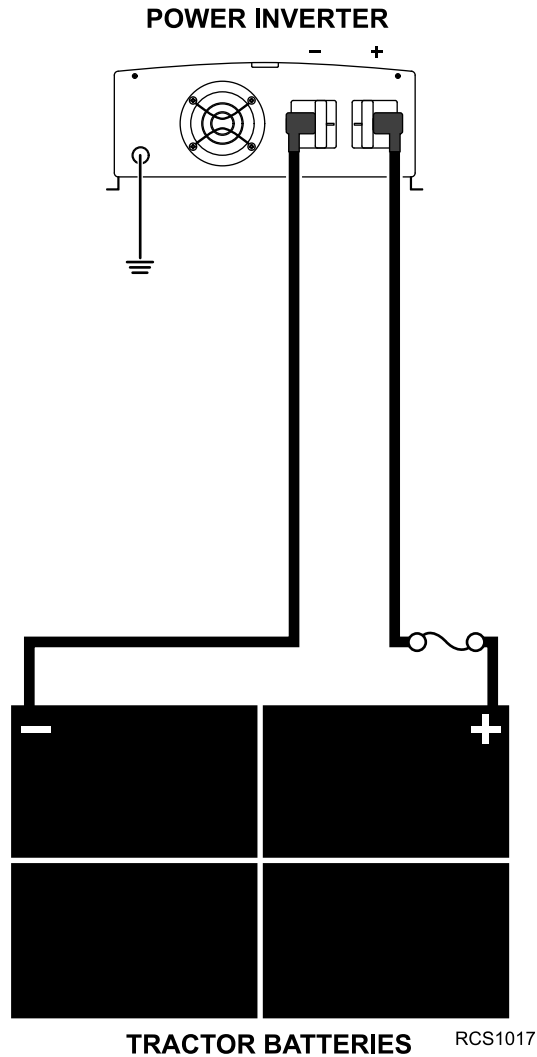

AC/DC Shore Power Converter Only

- Follow the installation instructions supplied with the AC/DC Power Converter.
- Connect tractor's batteries directly to converter as shown.

Important: DO NOT connect auxiliary power accessories to the TriPac ENVIDIA batteries.

Figure 33. AC/DC Shore Power Connections to Battery Shown.

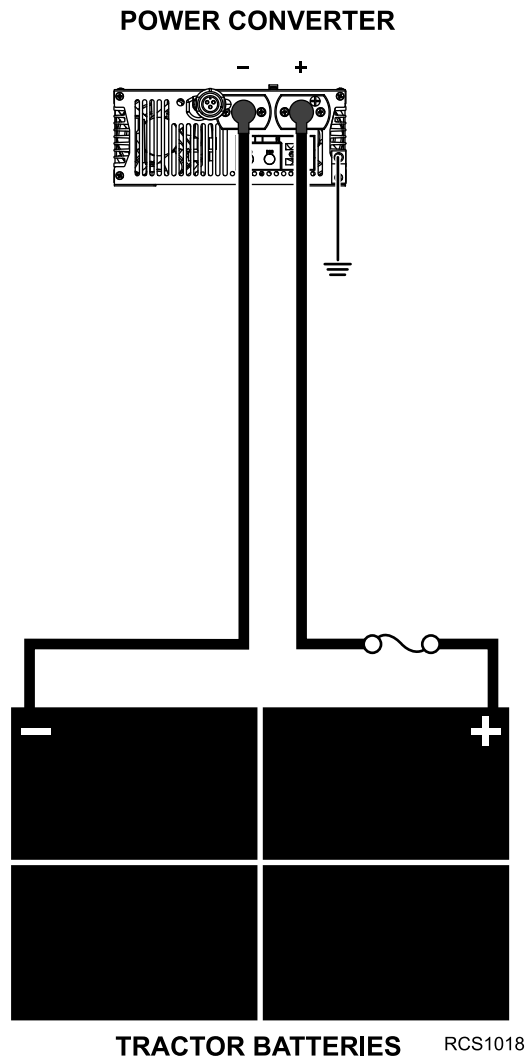

Dual System – DC/AC Power Inverter and AC/DC Shore Power Converter

- Follow the installation instructions supplied with the Power Inverter and AC/DC Power Converter.
- Connect tractor's batteries directly to inverter, then connect the converter to the inverter as shown.

Important: The tractor battery power cables must always be connected directly to the DC/AC POWER INVERTER.

Important: DO NOT connect auxiliary power accessories to the TriPac ENVIDIA batteries.

Figure 34. Dual System Connections to Battery Shown.

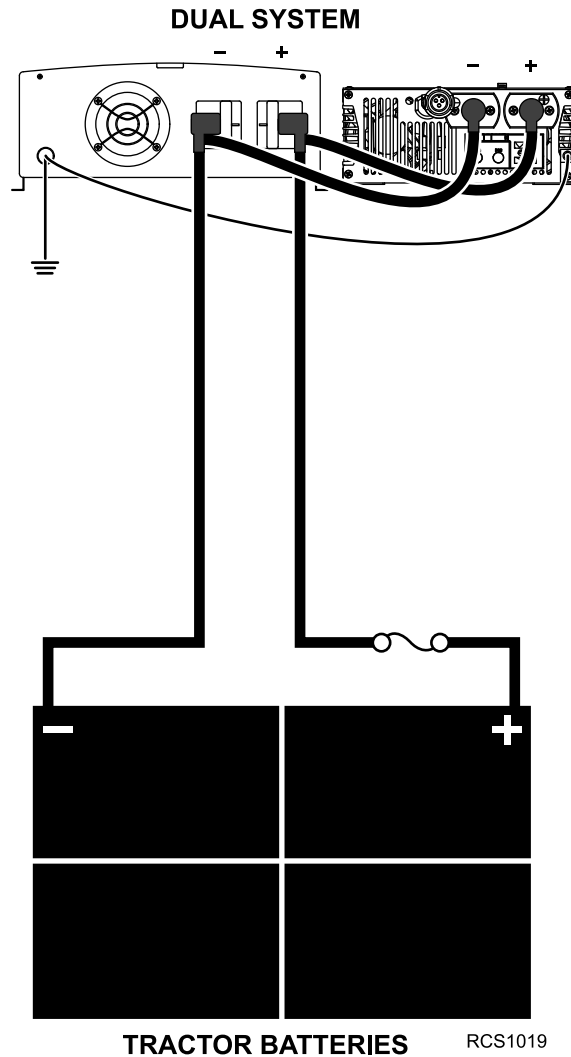

Battery Cable Installation

Important: See “Terminal Lug Standards” and “Fused Power Connection Standards” in the Electrical Standards” in Section 10 of the Thermo King TriPac Installation Standards Guide (TK 56498). THESE PROCEDURES MUST BE FOLLOWED!

TRUCK Battery Box Cable Connections

Note: Refer to the illustration on the following page.

Note: If truck batteries are being replaced that should be done now.

1. FUSE HOLDER

- a. Mount fuse holder securely with (installer supplied) 1/4-20 hardware and within 12.0 in. (304.8 mm) of the tractor batteries positive terminal.
- b. **DO NOT** install the fuse at this time.

2. POSITIVE BATTERY CABLE CONNECTION:

- a. Route the positive cable from the TriPac battery box to the fuse holder, cut to length and strip 1/2 to 3/4 in. (13 to 19 mm) of insulation from cable end.
- b. Slide the **RED** heat shrink tubing and terminal ring onto the end of the cable. Attach the terminal ring firmly to the cable.
- c. Position the heat shrink tubing to cover exposed wires on the terminal ring and use a heat gun to shrink the tubing in place.
- d. Temporarily install the positive cable terminal lug onto the fuse holder stud and loosely install the nut.

3. SHORT POSITIVE BATTERY CABLE CONNECTION:

- a. This cable has two different size battery lugs. Temporarily install cable lug with small hole onto the other fuse holder stud and loosely install the nut.
- b. Install the ring connector with the large hole onto the battery’s **POSITIVE (+)** connection and tighten securely.
- c. Apply Superlube (PN 203-524) or equivalent onto the battery’s connection only.

4. NEGATIVE BATTERY CABLE CONNECTION:

Note: Do not attach both the positive and the negative cables to a single battery. For best results, attach the positive cable to the first battery and the negative cable to the last battery as shown.

- a. Route the negative cable from the TriPac battery box to the tractor’s negative battery terminal, cut to length and strip 1/2 to 3/4 in. (13 to 19 mm) of insulation from cable end.
- b. Slide the **BLACK** heat shrink tubing and terminal ring onto the end of the cable. Attach the terminal ring firmly to end of cable.
- c. Position heat shrink tubing to cover exposed wires on the terminal ring and use a heat gun to shrink the tubing in place.
- d. Install the negative cable terminal lug onto the battery’s **NEGATIVE (-)** connection and tighten securely.
- e. Apply Superlube (PN 203-524) or equivalent onto the battery’s connection.

ENVIDIA Battery Box Cable Connections:

5. Inside the TriPac battery box, route and connect each positive battery cable to the corresponding positive battery post and tighten securely.
 - a. Apply Superlube (PN 203-524) or equivalent onto the battery’s connections.
 - b. Position the protective boots over the terminal lugs.

6. FUSE INSTALLATION

Important: FUSE MUST BE INSTALLED UNDER THE BATTERY CABLES.

- a. Remove nuts from the fuse holder and lift the battery cable lugs up off the studs.
- b. Install the 250 amp fuse onto the studs then reinstall the battery cable lugs.

Important: Ensure both sets of batteries are +/- .5 volts of each other to avoid spark.

Battery Cable Installation

- c. Reinstall the nuts and tighten them to 120 in-lb (13.5 Nm). **DO NOT** overtighten the nuts or the fuse holder will be damaged!
- d. Close the fuse holder cover securely.

The TriPac Envidia 2 system is now powered.

Figure 35. Battery Cables and Fuse Installation.

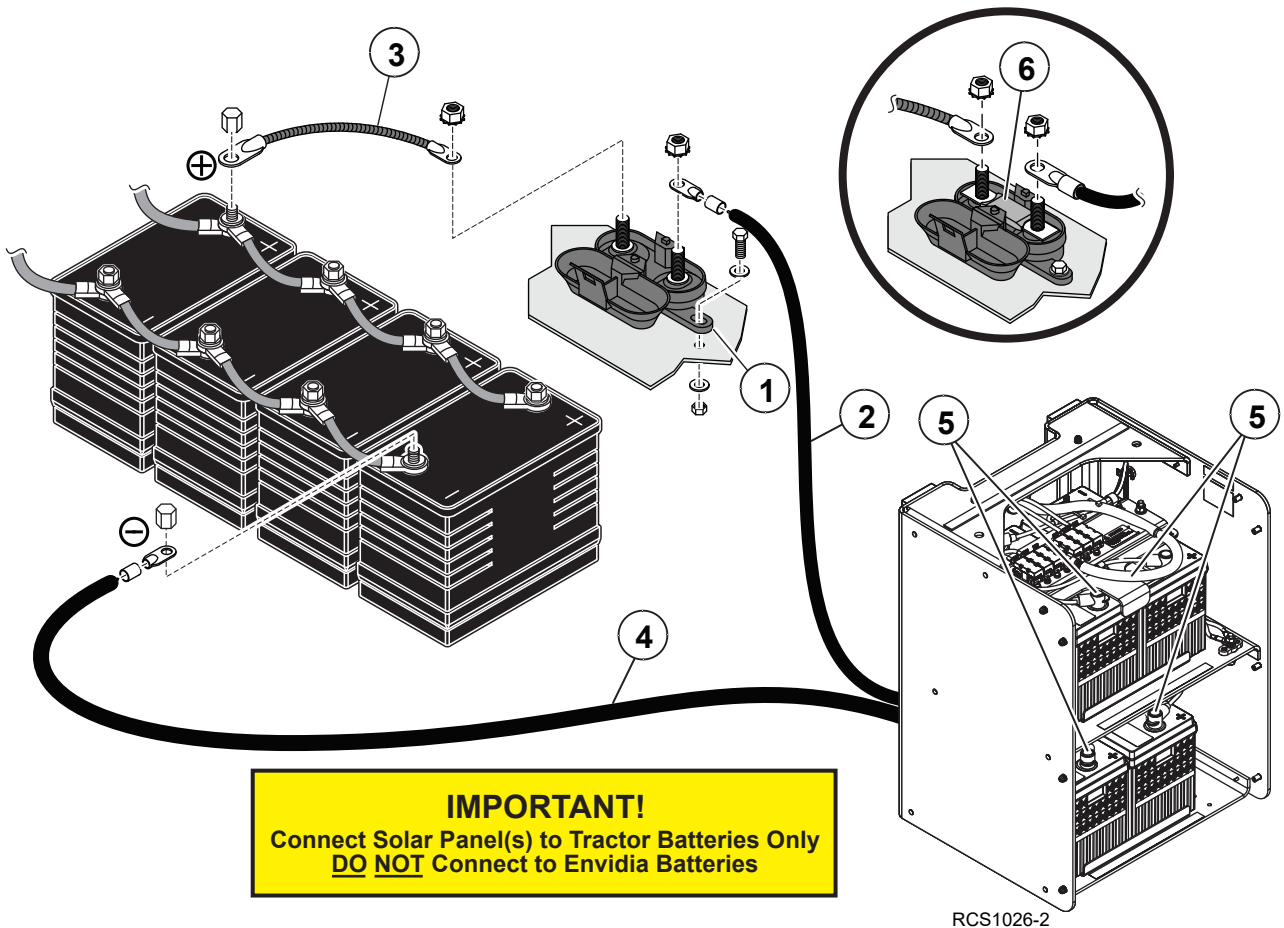

Priming the Heater Fuel Pump (Heat Option)

Important: It is important the heater fuel pump be primed before attempting to operate the heater for the first time. Failure to prime the pump will cause the unit to shutdown, set diagnostic codes and cause damage to the fuel pump.

Special Tools Required
Heater Priming Harness (204-1144)

Note: Verify there is a sufficient amount of fuel in the fuel tank before beginning the priming procedures.

The heater uses a pulse style fuel pump. You must use the heater priming harness to operate the fuel pump to prime the system. Applying continuous power to the pump will not work

1. Attach the **Heater Priming Harness** connector to the heater fuel pump.
2. Attach the alligator clips to the battery:
 - **RED to(+) Positive Battery Connection**
 - **BLACK to(-) Negative Battery Connection**
3. Turn the priming harness switch to the **"ON"** position.
4. The flasher unit will operate the fuel pump (ON/OFF/ON/OFF) to prime the system.
5. Allow the system to operate for approximately 5 minutes to bleed air from the fuel lines.

Note: Running the fuel pump longer than 5 minutes will cause the heater to emit excessive white smoke when operated.

6. Check fuel lines and system for leaks.
7. Turn the priming harness switch to the **"OFF"** position. Disconnect the positive and then the negative battery connections.
8. Disconnect the priming harness connector from the heater fuel pump.
9. Attach the heater fuel pump harness onto the heater fuel pump.

Figure 36. Heater Fuel Pump Priming Harness Connections.

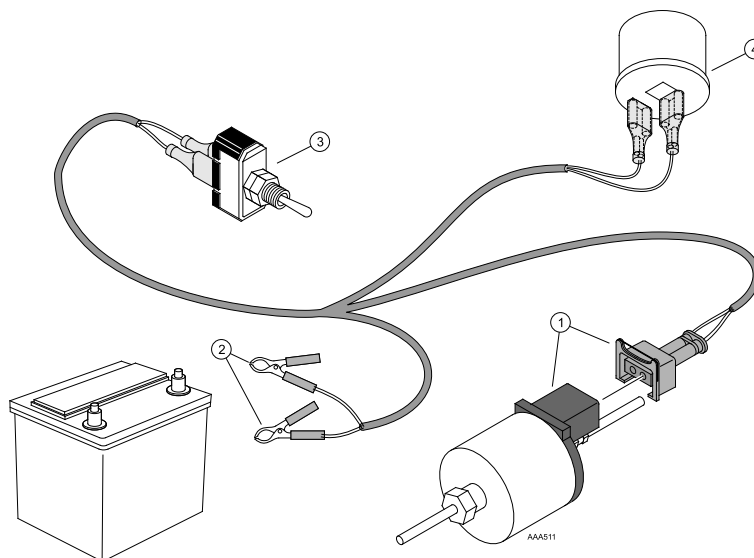

Heater Start-Up Procedures (Heat Option)

Note: See Operating and Diagnostic Manual TK 56464-19-OD for further diagnosis and service procedures if needed.

Special Tools Required
Heater Diagnostic Tool (204-1143)

Diagnostic Tool Overview

The diagnostic tool is used to read out, display and delete faults stored in the heater's electronic control box. It may also be used to start and run the heater.

- The test duration is limited to a maximum of 120 minutes.
- The electronic control box can store up to 5 faults.
- The current fault is displayed as "AF" and a 2-digit number and is always written in memory location F1.
- The stored faults "F1" to "F5" can be queried.

Perform the Start-Up Procedure

1. Verify the Heater harness is plugged into the J9 plug at the Evaporator/Control Box connector panel.
2. Connect the adapter harness to the Diagnostic Tool.
3. Connect the 8-pin diagnostic connector to the mating connector located on the heater harness inside the sleeper near the heater.

Note: The two remaining adapter harness connectors shown in the illustration are not used.

Figure 37. Heater Diagnostic Connections Shown.

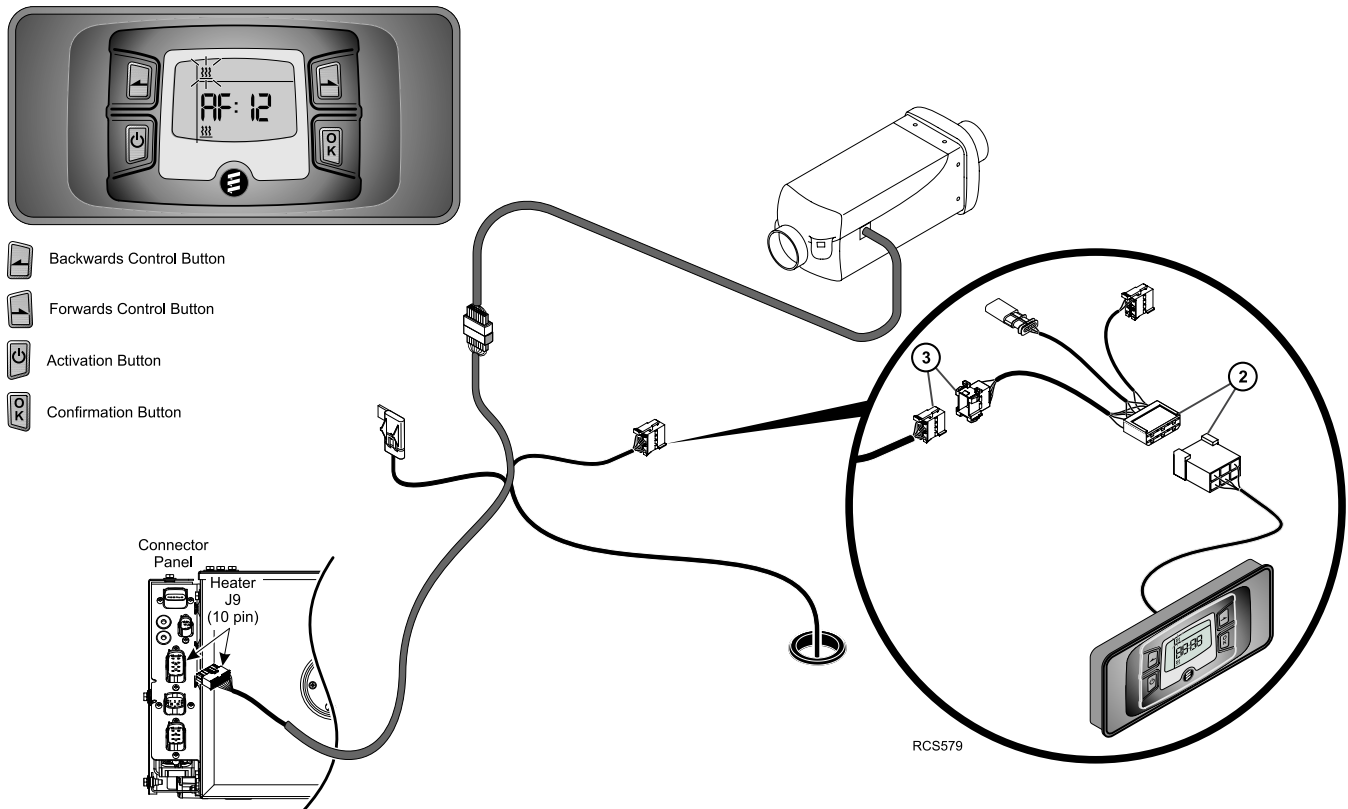

Automatic Detection

Five seconds after the diagnostic tool has been connected to the heater using the adapter cable, the automatic detection starts to determine the type of heater to which the diagnostic unit is connected.

Note: *If the automatic detection was successful, if necessary, the heater is briefly started and then switches off again.*

- Display until the automatic detection is completed.

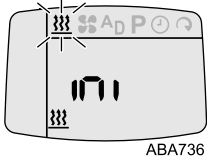

- Heater Icon will display when heater has been detected.

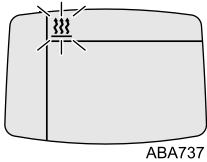

- Confirm flashing symbol with OK key.

Possible Displays:

- If no errors/faults exist go to Heater Start-up.

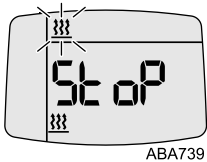

- If errors/faults exist go to Clearing Faults.

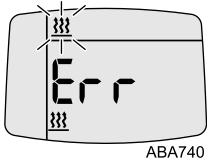

- Communication error. Go to Unable to Perform the Diagnosis.

Heater Start-Up

1. The heater will begin a four minute start up process:
 - Blower will start slow and heater will ignite.
 - Heat and blower will ramp up to high boost mode.
2. With the heater operating check the following:
 - a. Exhaust and intake hoses are installed and functioning correctly
 - b. Heat is blowing out of the heat duct inside the sleeper.
3. Press OK key to stop heater.
 - Heater will begin a four-minute cool-down mode.
4. Disconnect Diagnostic Unit from the heater harness.

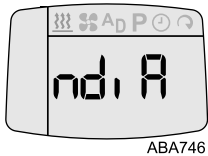

Clearing Faults

Display current fault in fault memory

1. Press Left and Right arrow keys simultaneously to display active or current faults in memory.
 - a. Display: e.g. AF: 12

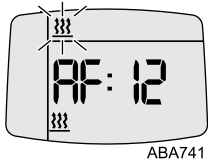

Display fault memory F1 – F5

2. Press Left or Right arrow keys to display any faults in memory.
 - a. a. Display: e.g. F1: 20

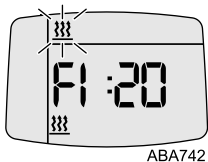

3. Record all fault codes. Refer to the diagnostic manual for an explanation of fault code diagnosis.

Display current fault in the fault memory again

4. Simultaneously press Left and Right arrow keys.
 - a. Display: e.g. AF: 12

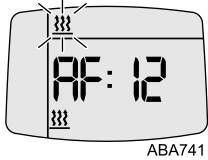

5. Delete the fault memory and as a result, at the same time cancel the control box lock.
 - Current fault or fault F1 – F5
6. Clear all faults and cancel control box lock by pressing OK key.
 - dEL will display.

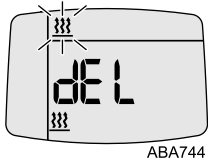

7. Press OK key again to confirm deletion.
 - The fault memory is deleted and the control box is unlocked.
 - Continue with Heater Start-Up or Diagnosis.

Quit Start-Up

1. Switch Off Heater. Press the OK key, heater is switched off.
 - a. Press the OK key, heater is switched off.
2. Perform the diagnosis again. Press the ON/OFF key, display is activated.
 - a. Press the ON/OFF key, display is activated.

Unable to Perform the Diagnosis**Automatic detection was unsuccessful**

- Display if the automatic detection was not successfully completed.

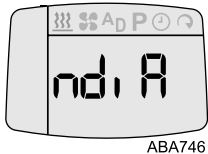
**Possible Causes:**

- Diagnostic harness not connected to heater harness
- Adapter plug not seated in diagnostic harness
- Defective diagnostic cable
- Defective heater.

A/C System Charging Procedures

Important: See "System Charging Standards" in Section 14 of the Thermo King TriPac Installation Standards Guide (TK 56498). **THESE STANDARDS MUST BE FOLLOWED!**

ADDING REFRIGERANT

Note: The system should be charged with refrigerant only after completing the Leak Check and Evacuation Procedures.

Special Tools Required
R-134a Refrigerant
Accurate Scale

1. Connect the refrigerant bottle to the gauge manifold and place it on a scale.
2. Open the refrigerant bottle valve for liquid and purge the charging line.
3. Keep the low pressure side valve of the gauge manifold closed. Open the high pressure side valve.
4. Add a partial refrigerant charge to the system. Liquid to high side.
5. Add remaining refrigerant charge as vapor to low side of system.

Note: The system never uses more than 2 lbs. of refrigerant. Accuracy is important. Over or under charging by 3 oz will reduce cooling capacity and reduce maximum system run time.

6. Close the refrigerant bottle valve and the high side valve of the gauge manifold.
7. Remove the gauge manifold.
8. Reinstall only the access cover over the evaporator coil.

Figure 38. TriPac Envidia Shown Connected to Refrigerant Bottle.

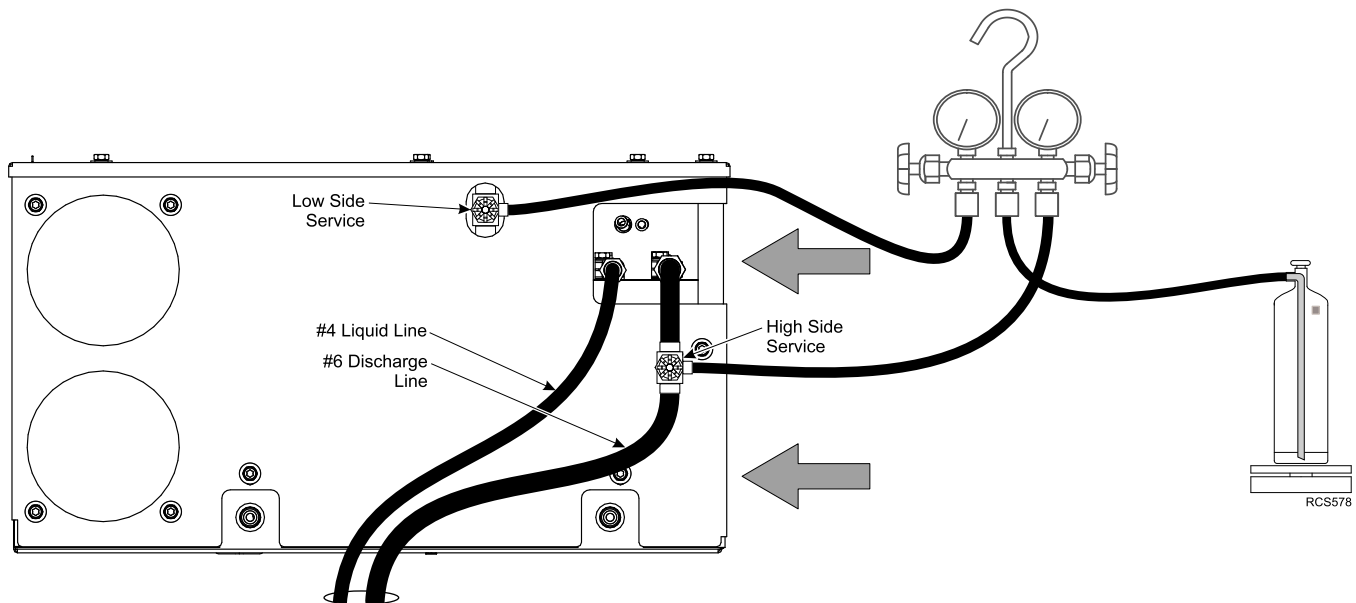

Operation Checkout Procedures

An operation checkout procedure must be performed after the TriPac Envidia 2 installation has been completed. This procedure will confirm the operation of the heating and air conditioning systems, and will verify the TriPac Envidia 2 batteries are charging and discharging properly. Any alarm codes that may have been set can also be checked and cleared. This checkout procedure will be done in two steps:

STEP 1— Use the TriPac HMI controller to verify basic system operation.

STEP 2— Use a laptop PC connected directly to the TriPac Base Controller module using the Envidia Service Tool and Service Test Mode to verify system operation in more detail. The Envidia Service Tool communication software is in the service computer and will transfer information directly to a laptop PC. This software provides the technician with system interface, flash load system upgrades, real time system information retrieval, Service Test Mode and Alarm clearing capabilities. The following tools will be required:

- Laptop Computer (IBM Compatible)
- USB Adapter Harness (204-2000 or USB Mini-B)
- Envidia Service Tool Software (See Envidia Service Tool Location Procedures below)

Evidia Service Tool Location Procedures
<p>Thermo King Technician or Installer Go to: www.thermoking.com</p> <ol style="list-style-type: none"> a. iService Login, provide user name and password b. Resources/Info Central/Software & Downloads/APU c. Click on "Envidia Service Tool" d. Select Save in the dialog box e. File will be saved to your default Downloads folder f. Locate the Envidia Service Tool.exe file. Move it to an easy to locate folder.
<p>Non-Thermo King Operator or Installer Go to: www.thermoking.com</p> <ol style="list-style-type: none"> a. North America/Products/Auxiliary Power Units b. Scroll to bottom of page. Select the TriPac Envidia "LEARN MORE" box. c. Select "DOWNLOADS" tab d. Select Envidia Service Tool "DOWNLOAD" box. Select Save in the dialog box e. File will be saved to your default Downloads folder f. Locate the Envidia Service Tool.exe file. Move it to an easy to locate folder

Step 1 – Basic Operation Checkout Procedures

The following basic operation checkout procedures will be performed using the TriPac Envidia 2HMI controller.

Note: Make sure the truck's engine is off and ignition switch is in the off position.

1. Rotate Mode Selection knob to **Fan Mode**.
2. Rotate Temperature Selection knob so white dot is at the top.
3. Press Mode Selection knob for at least one second to turn the TriPac Envidia system ON.
 - a. Fan icon should flash for several seconds then stay on.
 - b. Evaporator fan may not start.
 - c. Battery level bars should illuminate based on state of battery charge. It may take up to 30 seconds for the battery level bars to illuminate.
4. Rotate Fan Speed Selection knob clockwise.

Note: There will be a two second delay in response to changes made using the HMI Controller.

- a. Fan speed LED indicators should increase.
 - b. Evaporator fan speed should increase.
5. Rotate Fan Speed Selection knob counterclockwise.



Operation Checkout Procedures

- a. Fan speed LED indicators should decrease.
- b. Evaporator fan speed should decrease.
6. Rotate Temperature Selection knob *counterclockwise* to the blue stop.
7. Rotate Mode Selection knob to **Air Conditioning Mode**.
 - a. Snowflake icon should flash for several seconds then stay on.
 - b. Fan speed LEDs should turn off and AUTO indicator LED should come on. The fan should run in low.
 - c. If cab temperature is above 68 F the compressor may start and evaporator fan speed may increase.
8. Rotate Mode Selection knob to **Heat Mode**.
 - a. Heat icon should flash for several seconds then stay on.
 - b. Evaporator fan should stop or remain off.
 - c. The fan OFF indicator LED should come on.
 - d. Depending on cab temperature the heater may start.

Note: *If the heater ignites it will run for a minimum of 5 minutes. The blower will then run through a cool down cycle.*
 - e. Evaporator fan should not run.
 - f. Rotating the fan speed knob will start the evaporator fan.
9. **Battery Monitor Display**.
 - a. Watch battery level display for approximately 30 seconds.
 - b. At least four green battery level bars should illuminate steady green.
10. Press Mode Selection knob for at least three seconds to turn system OFF.
 - a. All indicator LEDs should turn off.
 - b. Evaporator fan should stop if running.

**THIS COMPLETES STEP 1 – VERIFYING BASIC SYSTEM OPERATIONS
CONTINUE TO STEP 2 – VERIFYING DETAILED SYSTEM OPERATIONS**

Step 2 - Detailed Operation Checkout Procedures

The following detailed unit setup and function checkout procedures will be performed using a laptop PC connected to the Base Controller module of the TriPac Envidia 2.

1. Verify the Envidia Service Tool program is installed on the service computer.
2. Verify the USB Adapter Harness is installed. It was connected to the USB Communication Port on the Base Controller module located on the Evaporator/Control box. The harness should have been routed to an easily accessible location. Do not connect to the computer at this time.
3. Press the HMI Mode Selection knob for at least one second to turn the TriPac Envidia 2 system ON.
 - a. The green Heart Beat LED on the Base Controller module should blink once per second.
4. Start the laptop PC.
5. Connect the USB Adapter Harness to a USB port on the laptop PC.
6. Start the Envidia Service Tool.
 - a. The Dashboard page should appear.

Unit Setup Procedures

1. From the Service Tool tabs select Unit Setup.
2. Enter the Unit Serial number.
3. Enter the Unit ID number.

- a. Any six alphanumeric characters.
- b. Typically truck number.
4. Verify Programmable Settings are correct for this installation. Recommend accepting default settings.
5. Select the check box next to Set Real Time Clock.
6. Select Save Setup

Envidia 2 HVAC Function Check Procedures

Air Conditioning Test

1. From the Envidia Service Tool tabs select Service Test.

Note: *The Service Test Mode allows the technician to force the system into a specific operating mode for a maximum of 15 minutes. After 15 minutes, the system will shut down and alarm 54 will be set indicating the Service Test Mode has been active for 15 minutes. Most tests can be accomplished in under 10 minutes.*

2. In the Service Test Screen, select Cool Test, then click Run Test. This test will verify the operation of the air conditioning components.

Note: *When you choose to run a test, "Running Service Test" will appear in the upper right on the screen. When you cancel a test, always allow the system time to respond before continuing.*

- a. Evaporator fan should run in high speed.
- b. A/C compressor should ramp up to high speed.
- c. Condenser fan should run in high speed.
- d. Discharge vent temperature should begin getting cooler.

Note: *If inside cab temperature is below 65 F (18.3 C) do not operate the COOL TEST for more than two minutes or the evaporator coil may freeze up.*

- e. After verification, correct response Exit the test.

Heat System Check

1. In the Service Test Screen, select Heat Test, then click Run Test. This test will verify the operation of the heating components.

- a. Evaporator fan should turn off.
- b. Heater blower should start slowly then begin to ramp up.
- c. After one minute the heater fuel pump near the fuel tank should begin clicking.
- d. After two minutes the heater should have ignited.
- e. Discharge vent temperature should begin rising.
- f. Blower speed should begin rising.
- g. Outside the cab, the velocity and temperature of the heater's exhaust should begin rising.
- h. After four minutes the heater should be in high heat (Boost) mode.
- i. At the end of five minutes exit the test.

2. In the Service Test screen, click Cancel Test.

- a. The fuel pump and burner should stop.
- b. The blower will continue to run for a four-minute cool down cycle.
- c. Blower speed will ramp down.
- d. Discharge vent temperature will decrease.

Note: *Selecting another operating mode or turning the system off will not terminate the cool down cycle. You may continue with the test procedures while in the cool down cycle.*

Fan Only Check

This function was already tested during the HMI Function Check.



Alarms

ALARM CODE CHART		
CODE NUMBER	CODE TYPE	CODE DESCRIPTION
02	CHECK	Evaporator Coil Sensor
03	CHECK	Return Air Sensor
05	CHECK	Ambient Air Sensor
10	SHUTDOWN	High Discharge Pressure
11	CHECK	Unit Controlling on Alternate Sensor
12	SHUTDOWN	Sensor Shutdown
23	SHUTDOWN	Cooling Cycle Fault
49	CHECK	Cab Temperature Sensor
54	SHUTDOWN	Test Mode Timeout
61	LOG CHECK SHUTDOWN	Low Battery Voltage
70	LOG	Hourmeter Failure
155	CHECK	Lost CAN Communication
180	CHECK, SHUTDOWN	Compressor Fault

1. Select Alarm tab.
2. Record any alarms shown. Refer to the Alarm Code Chart to diagnose and repair all alarm conditions.
3. Clear all alarms.

This completes the TriPac Envidia 2 operation checkout procedures.

Envidia 2 Battery Check Procedures

Battery Condition

1. Select System Monitoring tab.
2. Select SCM/Batteries at the top of the screen.
3. Verify that SYSTEM VOLTAGE reads above 12.3 Volt
 - a. If voltage is lower the batteries must be charged before proceeding.

Battery Discharge

1. Battery Discharge is already checked in Basic Operation Checkout Procedures.
2. When running HVAC in Cool, Heat or Fan modes AUXILIARY BATTERY STATUS in SCM and Batteries tab should indicate DISCHARGING

Battery Charge

1. Connect battery charger.
2. Turn the truck ignition switch to the ON position. Note: Truck engine not required to run. The AUXILIARY BATTERY STATUS in SCM and Batteries tab should indicate CHARGE.
3. System is in Charge Mode, verify HMI Battery Indicator shows scrolling Green Bars.
4. Turn truck ignition OFF.
5. Disconnect battery charger.

Note: The service test modes for Battery Charging, Battery Discharging and Battery Null are disabled for TriPac Envidia 2. Attempting to start these tests will pop-up a message saying "Unable to start test".

Exiting Envidia Service Tool

1. Close the Envidia Service Tool on computer.
2. Press the Mode Selection knob on the HMI for approximately three seconds to turn the TriPac Envidia 2 system OFF.
3. Disconnect the USB Adapter Harness from the PC.

For further diagnostic procedures see TriPac Envidia 2 Maintenance Manual (TK 57251-19-MM) and the TriPac Envidia 2 Operation and Diagnostic Manual (TK 57244-19-OD)



THERMO KING

Notes

Thermo King – by Trane Technologies (NYSE: TT), a global climate innovator – is a worldwide leader in sustainable transport temperature control solutions. Thermo King has been providing transport temperature control solutions for a variety of applications, including trailers, truck bodies, buses, air, shipboard containers and railway cars since 1938. For more information, visit www.thermoking.com or www.tranetechnologies.com.

Thermo King has a policy of continuous product and product data improvements and reserves the right to change design and specifications without notice. We are committed to using environmentally conscious print practices.